

# Company *Unser Unternehmen*



Founded in 1881, Peters + Bey is now being managed successfully in the fourth generation with the motto:

*Satisfied customers are our objective*

Originally active as a marine sheet metal working business which supplied ships in the port of Hamburg with sheet metal goods and galley inventory, the company today offers a comprehensive portfolio of services for shipping.

Due to more stringent safety requirements at sea, Peters + Bey began to design and manufacture navigation lights. Always leading in development, Peters + Bey is the world's first supplier of internationally authorised LED navigation lights for commercial shipping.

For more than 125 years, the Peters + Bey navigation lights have stood for quality and innovation throughout the world.

*Our range of services:*

**Production** with our own design and toolmaking for the fabrication of individual parts and series.

**Trading** competent in advice and delivery.

**Service** in the field of the maintenance of safety-relevant equipment.

**Store** with our own vehicle fleet as a distribution partner.

The collaboration in standards committees and associations ensures that the employees are always trained to the latest status of the developments and regulations.

*Gegründet im Jahre 1881 wird Peters + Bey mittlerweile in der 4. Generation erfolgreich geführt unter der Devise*

*Zufriedene Kunden sind unser Ziel*

*Ursprünglich tätig als Schiffsklempnerei, die im Hamburger Hafen Schiffe mit Blechwaren und Kombüseninventar belieferte bietet das Unternehmen heute ein umfangreiches Portfolio an Leistungen für die Schifffahrt.*

*Durch erhöhte Sicherheitsanforderungen auf See, begann Peters + Bey Navigationslaternen zu konstruieren und herzustellen. Stets führend in der Entwicklung ist Peters + Bey weltweit der erste Anbieter von international zugelassenen LED-Navigationslaternen für die Berufsschifffahrt.*

*Die Peters + Bey Navigationslaternen stehen weltweit seit mehr als 125 Jahren für Qualität und Innovation.*

*Unser Leistungsspektrum:*

**Produktion** mit eigener Konstruktion und Werkzeugbau für Einzelteil- und Serienfertigung.

**Handel** kompetent in Beratung und Lieferung.

**Service** im Bereich der Wartung von sicherheitsrelevanten Ausrüstungen.

**Lager** mit eigenem Fuhrpark als Distributionspartner.

*Durch Mitarbeit in Normenausschüssen und Verbänden wird sichergestellt, dass die Mitarbeiter stets auf dem aktuellen Stand der Entwicklungen und Vorschriften geschult sind.*



# Contents

## *Inhalt*

Our Company Production	Unser Unternehmen Produktion	02-03 06-07	Trade Service	Handel Service	08-09 10-11
---------------------------	---------------------------------	----------------	------------------	-------------------	----------------

### Navigation Lights *Navigationslaternen*

# 16

Lights for Vessels >50m, 760	Laternen Schiffe >50 m, 760	16	Signal Lights	Signalleuchten	48
Lights for Vessels >50m, 780	Laternen Schiffe >50 m, 780	28	Lights for Vessels <20m	Laternen Schiffe <20m	57
Lights for Vessels <50m, 500	Laternen Schiffe <50 m, 500	34	Navy Lanterns	Marinelaternen	73
Lights for Vessels <50m, 580	Laternen Schiffe <50 m, 580	41	Other LED Lights	LED-Leuchten	77

### Signals *Signale*

# 82

Acoustic Signals	Akustische Signale	82	Pyrotechnic Signals	Pyrotechnische Signale	94
Optical Signals	Optische Signale	85			

### Life Saving Appliances *Rettungsmittel*

# 102

Lifejackets	Rettungswesten	102	Rescue Apparatus	Sammelrettungsmittel	112
Survival Suits	Überlebensanzüge	108	Other Rescue Means	Sonstige Rettungsmittel	113
Life Rafts	Rettungsinseln	110	Accessories Rescue Means	Zubehör Rettungsmittel	114
Lifebuoys	Rettungsringe	111	Lights	Lichter	117

### Protective Equipment *Schutzausrüstung*

# 120

Gas Protection	Gasschutz	120	Fire Protection	Feuerschutz	142
Safety at Work	Arbeitsschutz	124	Other Personal Protection	Sonstiges PSA	146

### Fire Protection *Feuerschutz*

# 148

Extinguisher	Löcher	148	Escape Devices	Fluchtgeräte	170
Branch Pipes	Strahlrohre	156	Compressors	Kompressoren	172
Couplings	Kupplungen	158	Foam nozzle	Schaumlöscheinheit	174
Hoses	Schläuche	166	General Accessories	allgemeine Zubehör	175

# Contents

## *Inhalt*

Our Company	Unser Unternehmen	02-03	Trade	Handel	08-09
Production	Produktion	06-07	Service	Service	10-11

### Safety Equipment *Sicherheitsausrüstung*

# 178

Tapes	Tapes	178	Medical Equipment	Medizinische Ausrüstung	187
Oil Spill	Oil Spill	180	Others	Sonstiges	188
Measurement Instruments	Messgeräte	182			

### General Ship Equipment *Schiffsausrüstung*

# 194

Life Boat Inventory	Rettungsbootinventar	194	Lamps / Emitter	Lampen / Strahler	225
Bridge Equipment	Brückenzubehör	206	Other Marine Equipment	sonstige Schiffsausrüstung	232
ISPS	ISPS	217	Books	Bücher	241
Cases / Boxes	Kästen / Boxen	221	Hoses	Schläuche	243

### Signage *Beschilderung*

# 246

Galley Signs	Galley Signs	246	Poster	Poster	264
Panoramic Fire Signs	Panoramic Fire Signs	251	Mini Symbols	Mini Symbols	267
Mandatory Signs	Mandatory Signs	255	Miscellaneous Signs	Miscellaneous Signs	269
Prohibition Signs	Prohibition Signs	259	Other Signage	Sonstiges Beschilderung	270
ISPS Code Signs	ISPS Code Signs	262			

Index	272
-------	-----

# Production

## Produktion

The heart of Peters + Bey:  
Technical engineering to suit all needs.

Our own tool-making section plays a special role in the company. Regardless of what the industry needs, Peters + Bey can construct and manufacture all kinds of precision punching, deep drawing or welding parts. From the car industry to the furniture industry to the lighting industry or the varying tank manufacturing industry to the power saw manufacturing industry, Peters + Bey supplies them all, both on a national and on an international level. In doing so, Peters + Bey particularly enjoys the challenge that the production of prototypes can be offered. And with success. Besides the navigation lights that Peters + Bey produces for use in leisure and commercial shipping, we also manufacture custom-made products on special request – e.g. high grade products for the submarine navy.

The sheet metal forming process knows almost no boundaries: punching, deep drawing, turning, welding, spot-welding, soft and hard-soldering, riveting, vibratory finishing, grinding and polishing are all part of everyday life in the modern production halls equipped with CNC work stations, thus guaranteeing each and every customer quality right down as required.

Das Herzstück von Peters + Bey:  
Hochtechnische Produktion für jeden Bedarf.

*Das Leistungsspektrum umfasst die Einzelteil-, Baugruppen- und Serienfertigung, von Stückzahl „1 bis 100.000“. Durch die eigene Produktion und den eigenen Werkzeugbau werden komplexe Werkzeuge zur Serienherstellung von Einzelteilen konzipiert und gefertigt. Von der Auto-, Möbel-, Beleuchtungsindustrie bis zu Tankwagenherstellern und Motorsägenherstellern – alle werden von Peters + Bey versorgt – national und international. Dabei sind Anfertigungen von Prototypen eine besondere Herausforderung, der sich Peters + Bey gern stellt – mit Erfolg. Neben den weltweit bekannten Navigationslaternen für die Freizeit- und Berufsschifffahrt stellt Peters + Bey auch Sonderanfertigungen her, zum Beispiel besonders hochwertige Produkte, die im U-Boot-Bau eingesetzt werden.*

*Den Fertigungsverfahren in der Blechverarbeitung sind kaum Grenzen gesetzt: Stanzen, Tiefziehen, Nibbeln, Kanten, Schweißen, Punktschweißen, Weich- und Hartlöten, Nieten, Trowalieren, Schleifen und Polieren gehören zum Alltag in den modernen Produktionshallen mit CNC Arbeitsplätzen. So bekommt jeder Kunde Qualität auf den Punkt genau.*









# Trade *Handel*







Our qualified pool of employees guarantees competent advice and proper order processing.

**As a supplier in the fields of:**

- navigation lights
- acoustic and optical signal equipment
- life saving appliances
- personal protective equipment
- fire protection
- safety equipment
- general ship equipment
- signage
- tools
- catering (non-food)

we offer service from one source. Due to our own demands and due to the selection of the component suppliers, we guarantee high quality at favourable prices. The connected store ensures short access times to the articles and our own vehicle fleet permits flexible delivery periods. We also supply articles which are not listed in the catalogue.

Convince yourself of our efficiency and of the quality of our products.

*Unser qualifizierter Mitarbeiterpool garantiert kompetente Beratung und fachgerechte Auftragsabwicklung.*

*Als Anbieter in den Bereichen:*

- Navigationslaternen
- akustische und optische Signalmittel
- Rettungsmittel
- persönliche Schutzausrüstungen
- Feuerschutz
- Sicherheitsausrüstungen
- allgemeine Schiffsausrüstungen
- Beschilderungen
- Werkzeuge
- Gastronomie (Non-food)

*bieten wir Service aus einer Hand. Durch den eigenen Anspruch und die Auswahl der Zulieferer gewährleisten wir gehobene Qualität zu günstigen Preisen.*

*Das angeschlossene Lager sichert kurze Zugriffszeiten auf die Artikel und der eigene Fuhrpark ermöglicht flexible Lieferzeiten. Wir liefern auch Artikel, die nicht im Katalog gelistet sind.*

*Überzeugen Sie sich von unserer Leistungsfähigkeit und der Qualität unserer Produkte.*

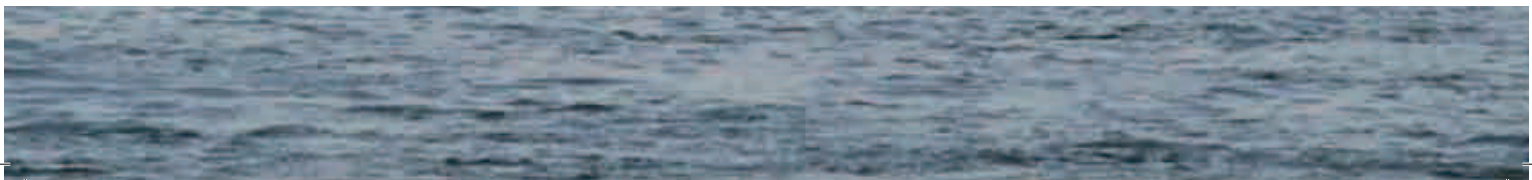
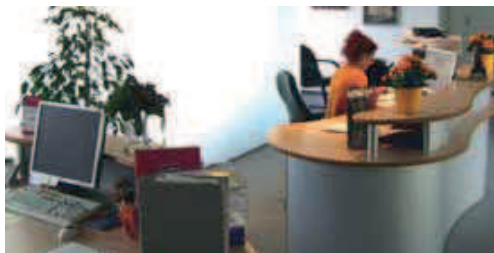

# Service *Service*

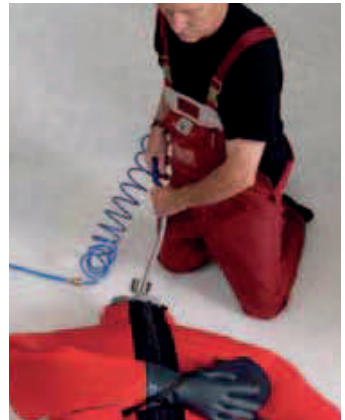





You can rely on our products. We ensure that this will remain so. Our comprehensive range of services on offer is at your disposal for this purpose.

Proper maintenance service by our own service personnel and competent partners guarantee processing and spare parts procurement on schedule. For the order processing period, we will be happy to provide hire devices upon request. As an additional service, we offer to assume responsibility for a maintenance pool of the customer's own devices. This service includes the administration, storage and distribution of the devices.

#### Rental business:

- Life jackets
- Measuring instruments
- Breathing apparatus
- EEBD's
- Gas protection suits

#### Maintenance:

- Gas protection suits
- Gas measuring instruments
- Breathing apparatus
- EEBD's
- Survival suits
- Inflatable life jackets
- Liferafts
- Fire extinguishers
- Medical oxygen

*Auf unsere Produkte ist Verlass. Wir sorgen dafür, dass es so bleibt. Dafür steht Ihnen unser umfangreiches Serviceangebot zur Verfügung.*

*Fachgerechter Wartungsdienst durch eigenes Servicepersonal und kompetente Partner gewährleisten eine termingerechte Abwicklung und Ersatzteilbeschaffung. Für die Zeit der Auftragsabwicklung stellen wir auf Wunsch gerne Leihgeräte zur Verfügung.*

*Als zusätzlichen Service bieten wir die Übernahme eines Wartungspools kundeneigener Geräte an.*

*Dieser Service beinhaltet die Verwaltung, die Lagerung und die Distribution der Geräte.*

#### Verleih:

- Rettungswesten
- Messgeräten
- Pressluftatmer
- EEBD's
- Gasschutzanzüge

#### Wartung:

- Gasschutzanzüge
  - Gasmessgeräte
  - Pressluftatmer
  - EEBD's
  - Überlebensanzüge
  - Aufblasbare Rettungswesten
  - Rettungsinseln
  - Feuerlöscher
  - Medizinischer Sauerstoff
- 

# Lights *Laternen*

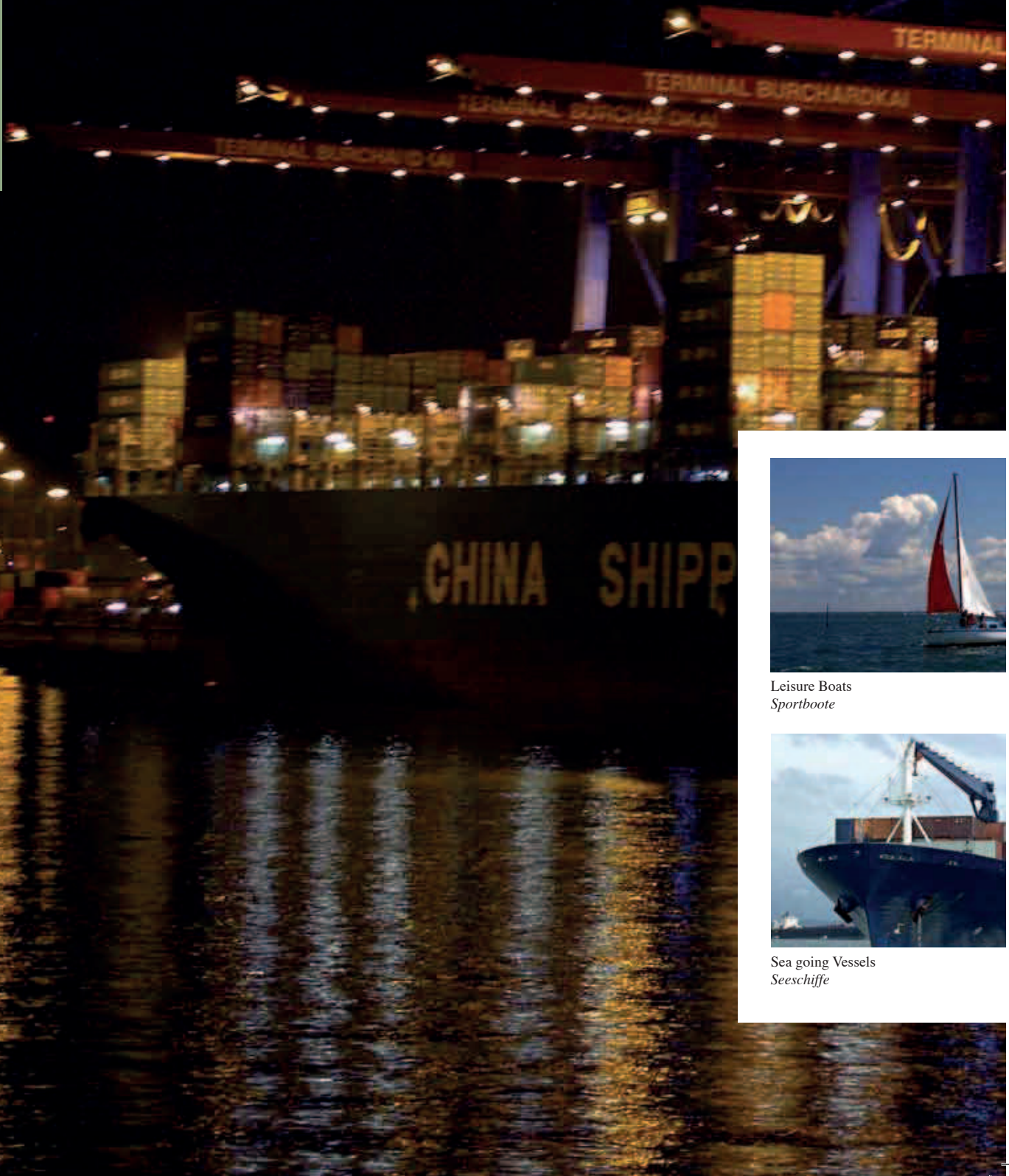

Leisure Boats  
*Sportboote*



Sea going Vessels  
*Seeschiffe*



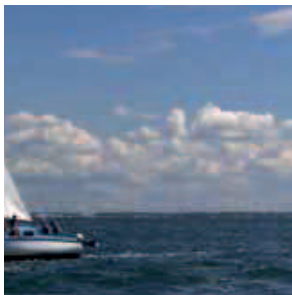

River Boats  
*Binnenschiffe*



Navy  
*Marine*

Vessels, *Schiffe* > 50 m

LED Light, *LED-Laternen* 780  
Lanterns, *Laternen* 760 / 767

Vessels up to, *Schiffe* < 50 m

LED Lights, *LED-Laternen* 580  
Lanterns, *Laternen* 500 / 507

Signal Lights, *Signallaternen*

Vessels, *Schiffe* < 20 m

Lanterns, *Laternen* 410 / 431 / 400  
420 / 421  
422 / 423  
426 / 427

Navy Lamps, *Marineleuchten*

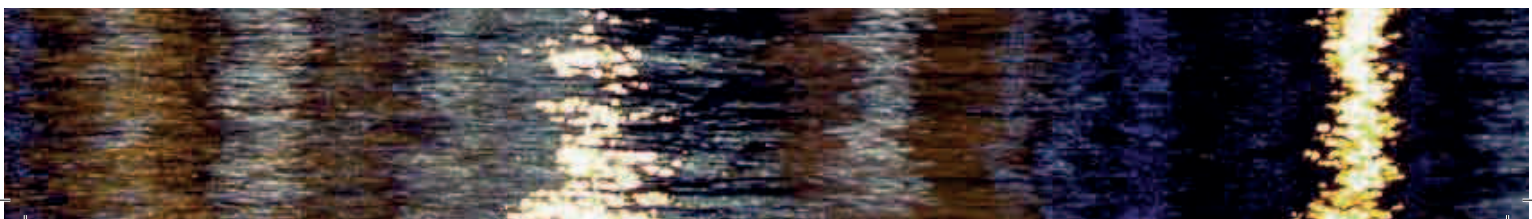
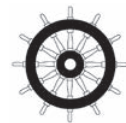

# Navigation Lights, Type 760

for vessels > 50 m

## *Navigationslaternen, Typ 760*

*für Schiffe > 50 m*

The development of Peters + Bey GmbH:  
125 years of experience in the construction and  
manufacture of navigation lights influenced the series  
of lanterns type 760.

*Die Eigenentwicklung der Peters + Bey GmbH:  
Über 125 Jahre Erfahrung bei der Konstruktion  
und Herstellung von Navigationslaternen haben  
die Entwicklung der Serie 760 beeinflusst.*

### Advantages:

- Every light is equipped with it's own terminal box.
- Marine cable is easy to terminate straight into the light.
- Durable materials and great structural strength withstand the tough sea conditions faced with every day.
- Easy one handed bulb exchange due to the tilting top housing of the double lantern.
- Simple exchange of spares. The modular built provides only few spares, each easy to mount.

### Vorteile:

- *Jede Laterne ist mit einer eigenen Anschlussbox ausgestattet. Das Anschlusskabel ist leicht direkt in der Laterne anzuschließen.*
- *Dauerhaft beständige Materialien und eine stabile Konstruktion sorgen dafür, dass die Laternen jeden Tag den außergewöhnlichen Bedingungen auf See standhalten.*
- *Leichter einhändiger Glühlampenwechsel, durch Klappen des Oberteils bei der Doppellaterne.*
- *Leichter Austausch von Ersatzteilen. Durch den modularen Aufbau der Laterne ergeben sich nur wenige Ersatzteile, welche im Bedarfsfall leicht zu montieren sind.*

### Options:

- On request the tilting mechanism may be supplied in one of 4 positions.
- Marine cable 1.50 m – H07 RN F2x1.5
- Upon request, Peters + Bey offers customized signalling lights with the respective flag state and class of your vessel. It is necessary to recognize signal lanterns from 360 degrees without shading > 6 degrees. If shading is > 6 degrees, should result from a mast, a chimney or a superstructures, we can manufacture 2 signal lanterns with different screens, which result in together 360 degrees.

### Optionen:

- *Der Klappmechanismus ermöglicht das Kippen der Doppellaterne in 4 unterschiedliche Richtungen.*
- *Kabelmontage 1,5m – H07 RN F2x1,5*
- *Peters + Bey erfüllt für die Signallaterne spezielle Kundenwünsche, in Übereinstimmung mit den Vorschriften vom Flaggenstaat des Schiffes. Es ist erforderlich, Signallaternen aus 360 Grad ohne eine Abschattung > 6 Grad zu erkennen. Sollte durch den Mast, Schornstein oder die aufbauten eine Abschattung > 6 Grad entstehen, können wir 2 Signallaternen mit unterschiedlichen Blenden herstellen, die zusammen die 360 Grad ergeben.*



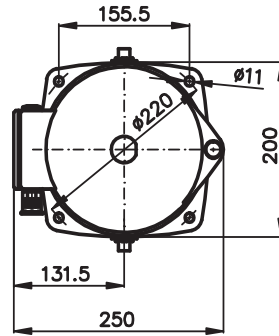

Single Lantern  
*Einzellaterne*

Single Lantern, hoistable  
*Einzellaterne, aufheizbar*

Double Lantern  
*Doppellaterne*

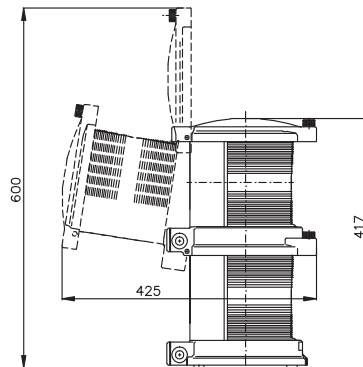
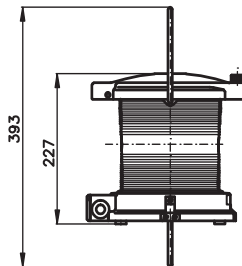
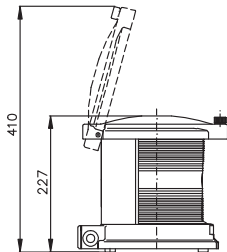

Technical data:

**Approvals:** BSH (Bundesamt für Seeschifffahrt und Hydrographie), GL (Germanischer Lloyd), UL 1104, MED

**Housing:** Black polyamid, glass fibre reinforced, shock resistant, non corrosive, non magnetic, seawater resistant, with stainless steel screens (1.4571)

**Connection:** Terminal box on every light

**Bulbholder:** P 28 s

**Lens:** PMMA

**Water proof:** EN 60945 (equivalent to IP 56)

Technische Daten:

**Zulassungen:** BSH (Bundesamt für Seeschifffahrt und Hydrographie), GL (Germanischer Lloyd), UL 1104, MED

**Gehäuse:** Schwarzes, glasfaserverstärktes Polyamid, korrosionsfrei, schocksicher, seewasserbeständig, antimagnetisch, Blenden aus Edelstahl (1.4571)

**Fassung:** P 28 s

**Linse:** PMMA

**Spritzwassergeschützt:** gemäß EN 60946 (vergleichbar zu IP 56)



Lanterns Type 760  
Laternen Typ 760

**Side Light**  
socket P28s  
visibility: 3nm

7611000

type: SSb 760 - green - without bulb

7611010

type: SSb 760 - green - 24V

7611020

type: SSb 760 - green - 115V

**Seitenlaterne**  
Fassung P28s  
Sichtweite: 3sm

Typ: SSb 760 - grün - ohne  
Glühlampe

Typ: SSb 760 - grün - 24V

Typ: SSb 760 - grün - 115V

**Double Side Light**  
socket P28s  
visibility: 3nm

7613000

type: DSSb 760 - green - without  
bulbs

7613010

type: DSSb 760 - green - 24V

7613020

type: DSSb 760 - green - 115V

7613030

type: DSSb 760 - green - 230V

7613040

type: DSSb 760 - green - 24/230V

**Doppel Seitenlaterne**  
Fassung P28s  
Sichtweite: 3sm

Typ: DSSb 760 - grün - ohne  
Glühlampe

Typ: DSSb 760 - grün - 24V

Typ: DSSb 760 - grün - 115V

Typ: DSSb 760 - grün - 230V

Typ: DSSb 760 - grün - 24/230V

**Side Light**  
socket P28s  
visibility: 3nm

7621000

type: SBb 760 - red - without bulb

7621010

type: SBb 760 - red - 24V

7621020

type: SBb 760 - red - 115V

7621030

type: SBb 760 - red - 230V

**Seitenlaterne**  
Fassung P28s  
Sichtweite: 3sm

Typ: SBb 760 - rot - ohne  
Glühlampe

Typ: SBb 760 - rot - 24V

Typ: SBb 760 - rot - 115V

Typ: SBb 760 - rot - 230V

Lanterns Type 760  
*Laternen Typ 760*



**Double Side Light**

socket: P28S  
 visibility: 3nm

**7623000**

type: DSBb 760 - red - without bulbs

**7623010**

type: DSBb 760 - red - 24V

**7623020**

type: DSBb 760 - red - 115V

**7623030**

type: DSBb 760 - red - 230V

**7623040**

type: DSBb 760 - red - 24/230V

**Doppel Seitenlaterne**

Fassung P28s  
 Sichtweite: 3sm

Typ: DSBb 760 - rot - ohne  
 Glühlampe

Typ: DSBb 760 - rot - 24V

Typ: DSBb 760 - rot - 115V

Typ: DSBb 760 - rot - 230V

Typ: DSBb 760 - rot - 24/230V



**Masthead Light**

socket P28s  
 visibility: 6nm

**7631000**

type: T 760 - white - without bulb

**7631010**

type: T 760 - white - 24V

**7631020**

type: T 760 - white - 115V

**7631030**

type: T 760 - white - 230V

**Toplaterne**

Fassung P28s  
 Sichtweite: 6sm

Typ: T 760 - weiß - ohne  
 Glühlampen

Typ: T 760 - weiß - 24V

Typ: T 760 - weiß - 115V

Typ: T 760 - weiß - 230V



**Double Masthead Light**

socket P28s  
 visibility: 6nm

**7633000**

type: DT 760 - white - without bulbs

**7633010**

type: DT 760 - white - 24V

**7633020**

type: DT 760 - white - 115V

**7633030**

type: DT 760 - white - 230V

**7633040**

type: DT 760 - weiss - 24/230V

**Doppel Toplaterne**

Fassung P28s  
 Sichtweite: 6sm

Typ: DT 760 - weiß - ohne  
 Glühlampen

Typ: DT 760 - weiß - 24V

Typ: DT 760 - weiß - 115V

Typ: DT 760 - weiß - 230V

Typ: DT 760 - weiß - 24/230V



Lanterns Type 760  
Laternen Typ 760

**Stern Light**  
socket P28s  
visibility: 3nm

7641000

type: H 760 - white reduced - without bulb

7641010

type: H 760 - white reduced - 24V

7641020

type: H 760 - white reduced - 115V

7641030

type: H 760 - white reduced - 230V

**Hecklaterne**  
Fassung P28s  
Sichtweite: 3sm

Typ: H 760 - weiß reduziert - ohne Glühlampe

Typ: H 760 - weiß reduziert - 24V

Typ: H 760 - weiß reduziert - 115V

Typ: H 760 - weiß reduziert - 230V

**Stern - Towing Light**  
socket P28s  
visibility: 3nm

7641200

type: HS 760 - yellow - without bulb

7641210

type: HS 760 - yellow - 24V

7641220

type: HS 760 - yellow - 115V

7641230

type: HS 760 - yellow - 230V

**Heck - Schleplaterne**  
Fassung P28s  
Sichtweite: 3nm

Typ: HS 760 - gelb - ohne Glühlampe

Typ: HS 760 - gelb - 24V

Typ: HS 760 - gelb - 115V

Typ: HS 760 - gelb - 230V

**Stern - Suez Light**  
socket P28s  
visibility: 3nm

7641600

type: HR 760 - red - without bulb

7641610

type: HR 760 - red - 24V

7641620

type: HR 760 - red - 115V

7641630

type: HR 760 - red - 230V

**Heck - Suezlaterne**  
Fassung P28s  
Sichtweite: 3sm

Typ: HR 760 - rot - ohne Glühlampe

Typ: HR 760 - rot - 24V

Typ: HR 760 - rot - 115V

Typ: HR 760 - rot - 230V



## Lanterns Type 760

### Laternen Typ 760



#### Double Stern - Suez Light

socket P28s  
visibility: 3nm

**7641800**

type: DHR 760 - red - without bulbs

**7641810**

type: DHR 760 - red - 24V

**7641820**

type: DHR 760 - red - 115V

**7641830**

type: DHR 760 - red - 230V

**7641840**

type: DHR 760 - red - 24/230V

#### Doppel Heck - Suezlaterne

Fassung P28s  
Sichtweite: 3sm

Typ: DHR 760 - rot - ohne  
Glühlampen

Typ: DHR 760 - rot - 24V

Typ: DHR 760 - rot - 115V

Typ: DHR 760 - rot - 230V

Typ: DHR 760 - rot - 24/230V



#### Double Stern Light

socket P28s  
visibility: 3nm

**7643000**

type: DH 760 - white reduced -  
without bulbs

**7643010**

type: DH 760 - white reduced - 24V

**7643020**

type: DH 760 - white reduced - 115V

**7643030**

type: DH 760 - white reduced - 230V

**7643040**

type: DH 760 - white reduced -  
24/230V

#### Doppel Hecklaterne

Fassung P28s  
Sichtweite: 3sm

Typ: DH 760 - weiß reduziert - ohne  
Glühlampen

Typ: DH 760 - weiß reduziert - 24V

Typ: DH 760 - weiß reduziert - 115V

Typ: DH 760 - weiß reduziert - 230V

Typ: DH 760 - weiß reduziert -  
24/230V



#### Double Stern Towing Light

socket P28s  
visibility: 3nm

**7643200**

type: DHS 760 - yellow - without  
bulbs

**7643210**

type: DHS 760 - yellow - 24V

**7643220**

type: DHS 760 - yellow - 115V

**7643230**

type: DHS 760 - yellow - 230V

**7643240**

type: DHS 760 - yellow - 24/230V

#### Doppel Heckschlepplaterne

Fassung P28s  
Sichtweite: 3sm

Typ: DHS 760 - gelb - ohne  
Glühlampen

Typ: DHS 760 - gelb - 24V

Typ: DHS 760 - gelb - 115V

Typ: DHS 760 - gelb - 230V

Typ: DHS 760 - gelb - 24/230V

Lanterns Type 760  
Laternen Typ 760



**Signal Light**  
socket P28s  
visibility: 3nm

7661000

type: AS 760 - white reduced - without bulb

7661010

type: AS 760 - white reduced - 24V *Typ: AS 760 - weiß reduziert - 24V*

7661020

type: AS 760 - white reduced - 115V *Typ: AS 760 - weiß reduziert - 115V*

7661030

type: AS 760 - white reduced - 230V *Typ: AS 760 - weiß reduziert - 230V*

**Signallaterne**  
Fassung P28s  
Sichtweite: 3sm

*Typ: AS 760 - weiß reduziert - ohne Glühlampe*



**Signal Light**  
socket P28s  
visibility: 3nm

7661200

type: AS 760 - red - without bulb *Typ: AS 760 - rot - ohne Glühlampe*

7661210

type: AS 760 - red - 24V *Typ: AS 760 - rot - 24V*

7661220

type: AS 760 - red - 115V *Typ: AS 760 - rot - 115V*

7661230

type: AS 760 - red - 230V *Typ: AS 760 - rot - 230V*

**Signallaterne**  
Fassung P28s  
Sichtweite: 3sm



**Signal Light**  
socket P28s  
visibility: 3nm

7661300

type: AS 760 - green - without bulb *Typ: AS 760 - grün - ohne Glühlampe*

7661310

type: AS 760 - green - 24V *Typ: AS 760 - grün - 24V*

7661320

type: AS 760 - green - 115V *Typ: AS 760 - grün - 115V*

7661330

type: AS 760 - green - 230V *Typ: AS 760 - grün - 230V*

**Signallaterne**  
Fassung P28s  
Sichtweite: 3sm



**Signal Light**  
socket P28s  
visibility: 3nm

7661400

type: AS 760 - yellow - without bulb *Typ: AS 760 - gelb - ohne Glühlampe*

7661410

type: AS 760 - yellow - 24V *Typ: AS 760 - gelb - 24V*

7661420

type: AS 760 - yellow - 115V *Typ: AS 760 - gelb - 115V*

7661430

type: AS 760 - yellow - 230V *Typ: AS 760 - gelb - 230V*

**Signallaterne**  
Fassung P28s  
Sichtweite: 3sm

Lanterns Type 760  
*Laternen Typ 760*



**Maneuvering Light**

socket P28s  
 visibility: 5sm

**7661700**

type: AM 760 - white - without bulb

**7661710**

type: AM 760 - white - 24V

**7661720**

type: AM 760 - white - 115V

**7661730**

type: AM 760 - white - 230V

**Anker Manöverlaterne**

Fassung P28s  
 Sichtweite: 5sm

Typ: AM 760 - weiß - ohne  
 Glühlampe

Typ: AM 760 - weiß - 24V

Typ: AM 760 - weiß - 115V

Typ: AM 760 - weiß - 230V



**Double Signal Light**

sockets P28s  
 visibility: 3nm

**7663100**

type: DAS 760 - white reduced -  
 without bulbs

**7663110**

type: DAS 760 - white reduced -  
 24V

**7663120**

type: DAS 760 - white reduced -  
 115V

**7663130**

type: DAS 760 - white reduced -  
 230V

**7663140**

type: DAS 760 - white reduced -  
 24/230V

**Doppel Signallaterne**

Fassung P28s  
 Sichtweite: 3sm

Typ: DAS 760 - weiß reduziert -  
 ohne Glühlampen

Typ: DAS 760 - weiß reduziert - 24V

Typ: DAS 760 - weiß reduziert -  
 115V

Typ: DAS 760 - weiß reduziert -  
 230V

Typ: DAS 760 - weiß reduziert -  
 24/230V



**Double Signal Light**

socket P28s  
 visibility: 3nm

**7663200**

type: DAS 760 - red - without bulbs

**7663210**

type: DAS 760 - red - 24V

**7663220**

type: DAS 760 - red - 115V

**7663230**

type: DAS 760 - red - 230V

**7663240**

type: DAS 760 - red - 24/230V

**Doppel Signallaterne**

Fassung P28s  
 Sichtweite: 3sm

Typ: DAS 760 - rot - ohne  
 Glühlampen

Typ: DAS 760 - rot - 24V

Typ: DAS 760 - rot - 115V

Typ: DAS 760 - rot - 230V

Typ: DAS 760 - rot - 24/230V



Lanterns Type 760  
*Laternen Typ 760*

**Double Signal Light**

socket P28s  
visibility: 3nm

**7663300**

type: DAS 760 - green - without bulbs

**7663310**

type: DAS 760 - green - 24V

**7663320**

type: DAS 760 - green - 115V

**7663330**

type: DAS 760 - green - 230V

**7663340**

type: DAS 760 - green - 24/230V

**Doppel Signallaterne**

Fassung P28s  
Sichtweite: 3sm

Typ: DAS 760 - grün - ohne Glühlampen

Typ: DAS 760 - grün - 24V

Typ: DAS 760 - grün - 115V

Typ: DAS 760 - grün - 230V

Typ: DAS 760 - grün - 24/230V

**Double Signal Light**

socket P28s  
visibility: 3nm

**7663400**

type: DAS 760 - yellow - without bulbs

**7663410**

type: DAS 760 - yellow - 24V

**7663420**

type: DAS 760 - yellow - 115V

**7663430**

type: DAS 760 - yellow - 230V

**7663440**

type: DAS 760 - yellow - 24/230V

**Doppel Signallaterne**

Fassung P28s  
Sichtweite: 3sm

Typ: DAS 760 - gelb - ohne Glühlampen

Typ: DAS 760 - gelb - 24V

Typ: DAS 760 - gelb - 115V

Typ: DAS 760 - gelb - 230V

Typ: DAS 760 - gelb - 24/230V

**Signal Light**

hoistable  
socket P28s  
visibility: 3nm

**7671000**

type: AS 767 - white reduced - without bulb

**7671010**

type: AS 767 - white reduced - 24V

**7671020**

type: AS 767 - white reduced - 115V

**7671030**

type: AS 767 - white reduced - 230V

**Signallaterne**

aufheissbar  
Fassung P28s  
Sichtweite: 3sm

Typ: AS 767 - weiß reduziert - ohne Glühlampe

Typ: AS 767 - weiß reduziert - 24V

Typ: AS 767 - weiß reduziert - 115V

Typ: AS 767 - weiß reduziert - 230V



Lanterns Type 760  
*Laternen Typ 760*



**Signal Light**

hoistable  
 socket P28s  
 visibility: 3nm

**7671200**

type: AS 767 - red - without bulb

**7671210**

type: AS 767 - red - 24V

**7671220**

type: AS 767 - red - 115V

**7671230**

type: AS 767 - red - Socket P28s

**Signallaterne**

aufheissbar  
 Fassung P28s  
 Sichtweite: 3sm

Typ: AS 767 - rot - ohne Glühlampe

Typ: AS 767 - rot - 24V

Typ: AS 767 - rot - 115V

Typ: AS 767 - rot - 230V



**Signal Light**

hoistable  
 socket P28s  
 Sichtweite: 3sm

**7671300**

type: AS 767 - green - without bulb

**7671310**

type: AS 767 - green - 24V

**7671320**

type: AS 767 - green - 115V

**7671330**

type: AS 767 - green - 230V

**Signallaterne**

aufheissbar  
 Fassung P28s  
 Sichtweite: 3sm

Typ: AS 767 - grün - ohne Glühlampe

Typ: AS 767 - grün - 24V

Typ: AS 767 - grün - 115V

Typ: AS 767 - grün - 230V



**Signal Light**

hoistable  
 socket P28s  
 visibility: 3nm

**7671400**

type: AS 767 - yellow - without bulb

**7671410**

type: AS 767 - yellow - 24V

**7671420**

type: AS 767 - yellow - 115V

**7671430**

type: AS 767 - yellow - 230V

**Signallaterne**

aufheissbar  
 Fassung P28s  
 Sichtweite: 3sm

Typ: AS 767 - gelb - ohne Glühlampe

Typ: AS 767 - gelb - 24V

Typ: AS 767 - gelb - 115V

Typ: AS 767 - gelb - 230V



**Bulb**

Danlamp

**7090150**

24 Volt - 40 Watt - socket P28s

**Glühlampe**

Danlamp

24 Volt - 40 Watt - Fassung P28s



Lanterns Type 760  
*Laternen Typ 760*

**Bulb**  
Danlamp

7090250

115 Volt - 60 Watt - socket P28s

7090350

230 Volt - 65 Watt - socket P28s

**Glühlampe**  
Danlamp

115 Volt - 60 Watt - Fassung P28s

230 Volt - 65 Watt - Fassung P28s



**Socket - P28s**

7419300

for PB - lantern 760

**Fassung - P28s**  
Rohteil

für Laterne Typ 760



**HNA - Plug**

1861000

110 Volt plastic

1862000

220 Volt plastic

**HNA - Stecker**

110 Volt Kunststoff

220 Volt Kunststoff



**HNA - Plug**

1861010

110 Volt brass

**HNA - Stecker**

110 Volt Messing



**HNA - Plug**

1862010

220 Volt brass

**HNA - Stecker**

220 Volt Messing



**HNA - Socket**  
with one cable entry

1862100

220 Volt brass

**HNA - Steckdose**  
mit einer Kabeleinführung

220 Volt Messing

Lanterns Type 760  
*Laternen Typ 760*



**Plug**

**1862400**

concentric - 24 V - 10 A plastic

**Stecker**

*konzentrisch 24V-10A Kunststoff*



**Plug socket**

**1862500**

concentric - 24 V - 10 A brass

**Steckdose**

*konzentrisch 24V-10A Messing*



**Morse tracer**

**7082500**

watertide - brass

**Morsetaster**

*Wasserdicht - Messing*



**Vibration Absorber**

**7098910**

for lanternseries 760 / 780

**Schwingungsdämpfer**

*für Laternenserie 760 / 780*

# LED Navigation Lights, Type 780

for vessels > 50 m

## LED Navigationslaternen, Typ 780

für Schiffe > 50 m



The lifetime of the single LED lantern is up to 50.000 hours. That means up to 100.000 hours for the double lanterns.

*Die LED Laternen haben eine Lebensdauer von 50.000 Stunden für Einfach- und 100.000 Stunden für Doppellaternen.*

The LED Navigation Light Type 780 is equipped with terminal boxes. The marine cable terminates straight into the light.

*Die LED Navigationslaterne Typ 780 ist mit Anschlussboxen ausgestattet. Das Anschlusskabel wird direkt in der Laterne installiert.*

Durable materials and great structural strength withstand the tough sea conditions faced with every day.

*Dauerhaft beständige Materialien und die stabile Konstruktion halten täglich den außergewöhnlichen Bedingungen auf See stand.*

### Technical data:

**Approval:** BSH (Bundesamt für Seeschifffahrt und Hydrographie), GL (Germanischer Lloyd), UL 1104, MED

**Housing:** Black polyamid, glass fibre reinforced, shock resistant, non corrosive, non magnetic, seawater resistant, with stainless steel screens (1.4571)

**Connection:** Terminal box on every light

**Lens:** PMMA

**Water Proof:** according to EN 60946 (equivalent to IP 56)

### Technische Daten:

**Zulassungen:** BSH (Bundesamt für Seeschifffahrt und Hydrographie), GL (Germanischer Lloyd), UL 1104, MED

**Gehäuse:** Schwarzes glasfaserverstärktes Polyamid, korrosionsfrei, schocksicher, seewasserbeständig, antimagnetisch, Blenden aus Edelstahl (1.4571)

**Anschluss:** Einzelne Anschlussbox für jede Laterne

**Linse:** PMMA

**Spritzwassergeschützt:** gemäß EN 60946 (vergleichbar zu IP 56)



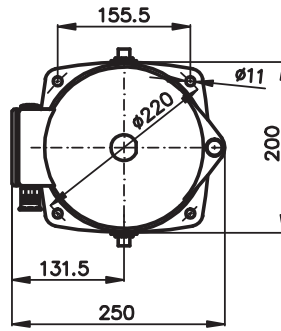

Double/Single Lantern  
Doppel-/Einzellaterne

Single Lantern, hoistable  
Einzellaterne, aufheißbar

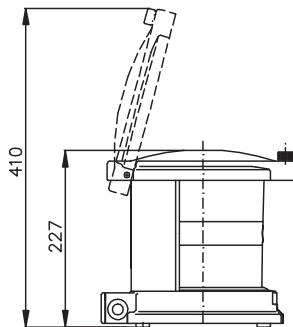

Advantages:

- Lifetime 50,000 hours (100.000 for double lanterns)
- Maintenance free
- Low power consumption
- No spare bulbs anymore.
- Single and double lanterns have the same dimension
- Every light is equipped with it's own terminal box
- Ship's cable is easy to terminate straight into the light
- Durable materials and great structural strength

Options:

- Marine cable 1.50 m – HO7 RN F2 x 1.5
- Solar/battery power for 24V supplies is available
- Upon request Peters + Bey offers customized signalling lights with the respective flag state and class of your vessel. It is necessary to recognize signal lantern from 360 degrees without shading > 6 degrees. If shading is > 6 degrees, should result from a mast, a chimney or a superstructures, we can manufacture 2 signal lanterns with different screens, which result in together 360 degrees.

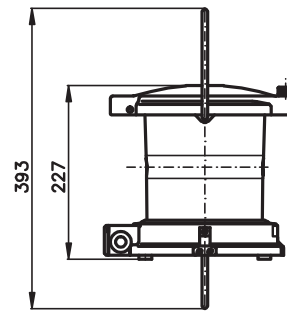

Vorteile:

- Lebensdauer von 50.000 Stunden (100.000 Stunden für Doppellaternen)
- Wartungsfrei
- Sparsamer Verbrauch
- Keine Ersatz-Glühlampen mehr
- Gleiche Abmessungen für Einzel-und Doppellaternen
- Jede Laterne ist mit eigener Anschlussbox ausgestattet
- Einfacher Kabelanschluss
- Beständige Materialien und stabile Konstruktion für dauerhafte Belastung.

Optionen:

- Anschlusskabel 1,50m – HO7 RN F2x1,5
- Solar/Batteriebetrieb für 24V möglich
- Peters + Bey erfüllt für die Signallaterne spezielle Kundenwünsche, in Übereinstimmung mit den Vorschriften vom Flaggenstaat des Schiffes. Es ist erforderlich, Signallaternen aus 360° ohne eine Abschattung > 6° zu erkennen. Sollte durch den Mast, Schornstein oder die Aufbauten eine Abschattung > 6° entstehen, können wir 2 Signallaternen mit unterschiedlichen Blenden herstellen, die zusammen die 360° ergeben.

Lanterns LED Type 780  
*Laternen LED Typ 780*



**LED - Side Light**

visibility: 3 nautical miles  
power consumption: 5 Watt

7811010

type: SSb 780 - green - 24V

7811020

type: SSb 780 - green - 115V

7811030

type: SSb 780 - green - 230V

**LED - Seitenlaterne**

Sichtweite: 3 Seemeilen  
Leistungsaufnahme: 5 Watt

Typ: SSb 780 - grün - 24V

Typ: SSb 780 - grün - 115V

Typ: SSb 780 - grün - 230V



**LED - Double Side Light**

visibility: 3 nautical miles  
power consumption: 5 Watt

7813010

type: DSSb 780 - green - 24V

7813020

type: DSSb 780 - green - 115V

7813030

type: DSSb 780 - green - 230V

7813040

type: DSSb 780 - green 24/230V

**LED - Doppel Seitenlaterne**

Sichtweite: 3 Seemeilen  
Leistungsaufnahme: 5 Watt

Typ: DSSb 780 - grün - 24V

Typ: DSSb 780 - grün - 115V

Typ: DSSb 780 - grün - 230V

Typ: DSSb 780 - grün - 24/230V



**LED - Side Light**

visibility: 3 nautical miles  
power consumption: 3 Watt

7821010

type: SBb 780 - red - 24V

7821020

type: SBb 780 - red - 115V

7821030

type: SBb 780 - red - 230V

**LED - Seitenlaterne**

Sichtweite: 3 Seemeilen  
Leistungsaufnahme: 3 Watt

Typ: SBb 780 - rot - 24V

Typ: SBb 780 - rot - 115V

Typ: SBb 780 - rot - 230V



**LED - Double Side Light**

visibility: 3 nautical miles  
power consumption: 3 Watt

7823010

type: DSBb 780 - red - 24V

7823020

type: DSBb 780 - red - 115V

7823030

type: DSBb 780 - red - 230V

7823040

type: DSBb 780 - red - 24/230V

**LED - Doppel Seitenlaterne**

Sichtweite: 3 Seemeilen  
Leistungsaufnahme: 3 Watt

Typ: DSBb 780 - rot - 24V

Typ: DSBb 780 - rot - 115V

Typ: DSBb 780 - rot - 230V

Typ: DSBb 780 - rot - 24/230V

Lanterns LED Type 780  
*Laternen LED Typ 780*

**LED - Masthead Light**

visibility: 6 nautical miles  
power consumption: 17 Watt



7831010

type: T 780 - white - 24V

7831020

type: T 780 - white - 115V

7831030

type: T 780 - white - 230V

**LED - Topplaterne**

Sichtweite: 6 Seemeilen  
Leistungsaufnahme: 17 Watt

Typ: T 780 - weiß - 24V

Typ: T 780 - weiß - 115V

Typ: T 780 - weiß - 230V

**LED - Double Masthead Light**

visibility: 6 nautical miles  
power consumption: 17 Watt



7833010

type: DT 780 - white - 24V

7833020

type: DT 780 - white - 115V

7833030

type: DT 780 - white - 230V

7833040

type: DT 780 - white - 24/230V

**LED - Doppel Topplaterne**

Sichtweite: 6 Seemeilen  
Leistungsaufnahme: 17 Watt

Typ: DT 780 - weiß - 24V

Typ: DT 780 - weiß - 115V

Typ: DT 780 - weiß - 230V

Typ: DT 780 - weiß - 24/230V

**LED - Stern Light**

visibility: 3 nautical miles  
power consumption: 3 Watt



7841010

type: H 780 - white - 24V

7841020

type: H 780 - white - 115V

7841030

type: H 780 - white - 230V

**LED - Hecklaterne**

Sichtweite: 3 Seemeilen  
Leistungsaufnahme: 3 Watt

Typ: H 780 - weiß - 24V

Typ: H 780 - weiß - 115V

Typ: H 780 - weiß - 230V

**LED - Stern Towing Light**

visibility: 3 nautical miles  
power consumption: 6 Watt



7841210

type: HS 780 - yellow - 24V

7841220

type: HS 780 - yellow - 115V

7841230

type: HS 780 - yellow - 230V

**LED - Heck-Schlepplaterne**

Sichtweite: 3 Seemeilen  
Leistungsaufnahme: 6 Watt

Typ: HS 780 - gelb - 24V

Typ: HS 780 - gelb - 115V

Typ: HS 780 - gelb - 230V



Lanterns LED Type 780  
Laternen LED Typ 780



**LED - Stern - Suez Light**  
visibility: 3 nautical miles  
power consumption: 3 Watt

7841610

type: HR 780 - red - 24V

7841620

type: HR 780 - red - 115V

7841630

type: HR 780 - red - 230V

**LED - Heck-Suezlaterne**  
Sichtweite: 3 Seemeilen  
Leistungsaufnahme: 3 Watt

Typ: HR 780 - rot - 24V

Typ: HR 780 - rot - 115V

Typ: HR 780 - rot - 230V



**LED - Double Stern-Suez Light**  
visibility: 3 nautical miles  
power consumption: 3 Watt

7841810

type: DHR 780 - red - 24V

7841820

type: DHR 780 - red - 115V

7841830

type: DHR 780 - red - 230V

7841840

type: DHR 780 - red - 24/230V

**LED - Doppel Heck-Suezlaterne**  
Sichtweite: 3 Seemeilen  
Leistungsaufnahme: 3 Watt

Typ: DHR 780 - rot - 24V

Typ: DHR 780 - rot - 115V

Typ: DHR 780 - rot - 230V

Typ: DHR 780 - rot - 24/230V



**LED - Double Stern Light**  
visibility: 3 nautical miles  
power consumption: 3 Watt

7843010

type: DH 780 - white - 24V

7843020

type: DH 780 - white - 115V

7843030

type: DH 780 - white - 230V

7843040

type: DH 780 - white - 24/230V

**LED - Doppel Hecklaterne**  
Sichtweite: 3 Seemeilen  
Leistungsaufnahme: 3 Watt

Typ: DH 780 - weiß - 24V

Typ: DH 780 - weiß - 115V

Typ: DH 780 - weiß - 230V

Typ: DH 780 - weiß - 24V



**LED - Double Stern Light**  
visibility: 3 nautical miles  
power consumption: 6 Watt

7843210

type: DHS 780 - yellow - 24V

7843220

type: DHS 780 - yellow - 115V

7843230

type: DHS 780 - yellow - 230V

7843240

type: DHS 780 - yellow - 24/230V

**LED - Doppel Heck - Schlepplaterne**  
Sichtweite: 3 Seemeilen  
Leistungsaufnahme: 6 Watt

Typ: DHS 780 - gelb - 24V

Typ: DHS 780 - gelb - 115V

Typ: DHS 780 - gelb - 230V

Typ: DHS 780 - gelb - 24/230V

Lanterns LED Type 780  
*Laternen LED Typ 780*



**LED Signal Light**  
 visibility: 3 nautical miles  
 power consumption: 8 Watt

7861010

type: AS 780 - white - 24V

7861020

type: AS 780 - white - 115V

7861030

type: AS 780 - white - 230V

**LED - Signallaterne**  
 Sichtweite: 3 Seemeilen  
 Leistungsaufnahme: 8 Watt

Typ: AS 780 - weiß - 24V

Typ: AS 780 - weiß - 115V

Typ: AS 780 - weiß - 230V



**LED Signal Light**  
 visibility: 3 nautical miles  
 power consumption: 6 Watt

7861210

type: AS 780 - red - 24V

7861220

type: AS 780 - red - 115V

7861230

type: AS 780 - red - 230V

**LED - Signallaterne**  
 Sichtweite: 3 Seemeilen  
 Leistungsaufnahme: 6 Watt

Typ: AS 780 - rot - 24V

Typ: AS 780 - rot - 115V

Typ: AS 780 - rot - 230V



**LED Signal Light**  
 visibility: 5 nautical miles  
 power consumption: 18 Watt

7861710

type: AM 780 - white - 24V

7861720

type: AM 780 - white - 115V

7861730

type: AM 780 - white - 230V

**LED - Signallaterne**  
 Sichtweite: 5 Seemeilen  
 Leistungsaufnahme: 18 Watt

Typ: AM 780 - weiß - 24V

Typ: AM 780 - weiß - 115V

Typ: AM 780 - weiß - 230V



**LED - Double Signal Light**  
 visibility: 3 nautical miles  
 power consumption: 6 Watt

7863210

type: DAS 780 - red - 24V

7863220

type: DAS 780 - red - 115V

7863230

type: DAS 780 - red - 230V

7863240

type: DAS 780 - red - 24/230V

**LED - Doppel Signallaterne**  
 Sichtweite: 3 Seemeilen  
 Leistungsaufnahme: 6 Watt

Typ: DAS 780 - rot - 24V

Typ: DAS 780 - rot - 115V

Typ: DAS 780 - rot - 230V

Typ: DAS 780 - rot - 24/230V



Lanterns LED Type 780  
*Laternen LED Typ 780*

**LED - Double Signal Light**

visibility: 3 nautical miles  
power consumption: 10 Watt

**7863310**

type: DAS 780 - green - 24V

**7863320**

type: DAS 780 - green - 115V

**7863330**

type: DAS 780 - green - 230V

**7863340**

type: DAS 780 - green - 24/230V

**LED - Doppel Signallaterne**

Sichtweite: 3 Seemeilen  
Leistungsaufnahme: 10 Watt

Typ: DAS 780 - grün - 24V

Typ: DAS 780 - grün - 115V

Typ: DAS 780 - grün - 230V

Typ: DAS 780 - grün - 24/230V



**Control Unit**

type: PB-NLCP  
for maximum 8 Basis Measuring  
Modules  
12/24/115/230 Volt  
inclusive Software licence

**7800100**

for Navigation Light Panel

**Steuereinheit**

Typ: PB-NLCP  
für maximal 8 Basis Messeinheiten  
12/24/115/230 Volt  
inklusive Softwarelizenz

für Navigations Laternen Panel



**Basis Measuring Module**

type: PB-MM-Basis  
12/24/115/230 Volt  
for maximum 8 single lanterns  
LED or conventional version

**7800101**

for Navigation Light Panel

**Basis - Messeinheit**

Typ: PB-MM-Basis  
12/24/115/230 Volt  
für maximum 8 Einzellaternen  
LED oder konventionelle  
Ausführung

für Navigationslaternen Panel



**Measuring Card**

type: PB-MM  
115/230 Volt  
for 2 single lanterns  
LED or conventional version

**7800102**

for Navigation Light Panel

**Messkarte**

Typ: PB-MM  
115/230 Volt  
für 2 Einzellaternen  
LED oder konventionelle  
Ausführung

für Navigationslaternen Panel



**Measuring Card**

type: PB-MM  
10-30 Volt  
for 2 single lanterns  
LED or conventional version

**7800103**

for Navigation Light Panel

**Messkarte**

Typ: PB-MM  
10-30 Volt  
für 2 Einzellaternen  
LED oder konventionelle  
Ausführung

für Navigationslaternen Panel



**Touchscreen - 13,3" - TFT**

Manufacturer: Hatteland  
IntelNM10 Atom 1.66GHz 1GBRAM  
8GBSSD-M OSNone 2xDC  
24V - 400 cd/m<sup>2</sup> - 1280x800  
according to EN60945

**7800104**

type: HD 13T21 MMC-E1C-PABA

**Touchscreen - 13,3" - TFT**

Hersteller: Hatteland  
IntelNM10 Atom 1.66GHz 1GBRAM  
8GBSSD-M OSNone 2xDC  
24V - 400 cd/m<sup>2</sup> - 1280x800  
geprüft nach EN60945

Typ: HD 13T21 MMC-E1C-PABA



# Navigation Lights, Type 500

for vessels 20 - 50 m

## Navigationsslaternen, Typ 500

für Schiffe 20 - 50 m



Single Lantern  
Einzellaterne

Single Lantern, hoistable  
Einzellaterne, aufheißbar

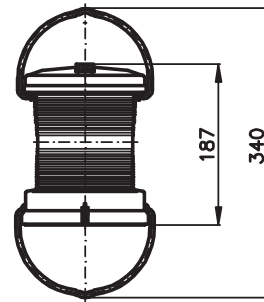
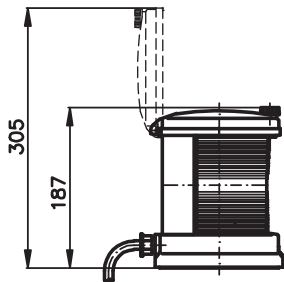
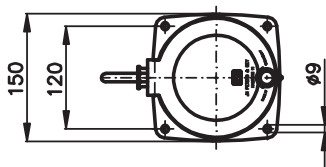

Top stability in sight: our Navigation Lights Type 500 for all vessels of 20 metres but less than 50 metres in length according International Regulations for Preventing Collisions at Sea. 1972 (72 COLREGS-IMO72) and the Rhine inland waterway regulation.

### Advantages:

- Waterlight cable insert, fitted with 1.5m cable
- Mounting by means of 4 bolts M-8
- Waterlight housing, degree IP 56
- Housing of glass-reinforced polycarbonate offers high rigidity
- Outstanding dimensional stability and excellent fatigue endurance
- All lights can be delivered as custom made version, e.g. polished
- Fixed mounting or hoistable version

### Approval:

BSH (Bundesamt für Seeschifffahrt und Hydrographie), GL (Germanischer Lloyd), UL 1104, MED

*Hohe Stabilität in Sicht: Unsere Laternen Typ 500. Nach der Seestraßenordnung 1972 und internationalen Regeln für Seeschiffe von mehr als 20m Länge und weniger als 50m Länge. Nach der Binnenschifffahrtstraßenordnung für alle Binnenschiffe bis an die Grenze der Seefahrt zugelassen durch das Deutsche Hydrografische Institut.*

### Vorteile:

- Wasserdichte Kabeleinführung mit installiertem Anschlusskabel von 1,5m Länge
- Befestigung der Laternen erfolgt mit 4 Schrauben M-8 (Sonderzubehör)
- Wasserdichte Gehäuse. Schutzart IP 56
- Gehäuse aus Polycarbonat mit hoher mechanischer Stabilität und Ermüdungsfestigkeit
- Festanbau und aufheißbar

### Zulassungen:

BSH (Bundesamt für Seeschifffahrt und Hydrographie), GL (Germanischer Lloyd), UL 1104, MED

Lanterns Type 500  
Laternen Typ 500



**Side Light**  
socket BAY15d  
visibility: 2nm

5011200

type: SSb 500 - green - without bulb

5011210

type: SSb 500 - green - 12V

5011220

type: SSb 500 - green - 24V

**Seitenlaterne**  
Fassung BAY15d  
Sichtweite: 2sm

Typ: SSb 500 - grün - ohne  
Glühlampe

Typ: SSb 500 - grün - 12V

Typ: SSb 500 - grün - 24V



**Side Light**  
socket BAY15d  
visibility: 2nm

5021200

type: SBb 500 - red - without bulb

5021210

type: SBb 500 - red - 12V

5021220

type: SBb 500 - red - 24V

**Seitenlaterne**  
Fassung BAY15d  
Sichtweite: 2sm

Typ: SBb 500 - rot - ohne  
Glühlampe

Typ: SBb 500 - rot - 12V

Typ: SBb 500 - rot - 24V



**Masthead Light**  
socket BAY15d  
visibility: 5nm

5031600

type: T 500 - white - without bulb

5031610

type: T 500 - white - 12V

5031620

type: T 500 - white - 24V

**Topplaterne**  
Fassung BAY15d  
Sichtweite: 5sm

Typ: T 500 - weiß - ohne Glühlampe

Typ: T 500 - weiß - 12V

Typ: T 500 - weiß - 24V



**Stern Light**  
socket BAY15d  
visibility: 2nm

5041400

type: H 500 - white reduced -  
without bulb

5041410

type: H 500 - white reduced - 12V

5041420

type: H 500 - white reduced - 24V

**Hecklaterne**  
Fassung BAY15d  
Sichtweite: 2sm

Typ: H 500 - weiß reduziert - ohne  
Glühlampe

Typ: H 500 - weiß reduziert - 12V

Typ: H 500 - weiß reduziert - 24V

Lanterns Type 500  
*Laternen Typ 500*



**Stern - Towing Light**

socket BAY15d  
 visibility: 2nm

5041500

type: HS 500 - yellow - without bulb

5041510

type: HS 500 - yellow - 12V

5041520

type: HS 500 - yellow - 24V

**Heck - Schleplaterne**

Fassung BAY15d  
 Sichtweite: 2sm

Typ: HS 500 - gelb - ohne  
 Glühlampe

Typ: HS 500 - gelb - 12V

Typ: HS 500 - gelb - 24V



**Signal Light**

socket BAY15d  
 visibility: 2nm

5062000

type: AS 500 - white reduced -  
 without bulb

5062020

type: AS 500 - white reduced - 12V

5062030

type: AS 500 - white reduced - 24V

**Signallaterne**

Fassung BAY15d  
 Sichtweite: 2sm

Typ: AS 500 - weiß reduziert - ohne  
 Glühlampe

Typ: AS 500 - weiß reduziert - 12V

Typ: AS 500 - weiß reduziert - 24V



**Maneuvering Light**

socket BAY15d  
 visibility: 5nm

5062010

type: AM 500 - white - without bulb

5062040

type: AM 500 - white - 12V

5062050

type: AM 500 - white - 24V

**Anker - Manöverlaterne**

Fassung BAY15d  
 Sichtweite: 5sm

Typ: AM 500 - weiß - ohne  
 Glühlampe

Typ: AM 500 - weiß - 12V

Typ: AM 500 - weiß - 24V



**Signal Light**

socket BAY15d  
 visibility: 2nm

5062100

type: AS 500 - red - without bulb

5062110

type: AS 500 - red - 12V

5062120

type: AS 500 - red - 24V

**Signallaterne**

Fassung BAY15d  
 Sichtweite: 2sm

Typ: AS 500 - rot - ohne Glühlampe

Typ: AS 500 - rot - 12V

Typ: AS 500 - rot - 24V



Lanterns Type 500  
Laternen Typ 500



**Signal Light**  
socket BAY15d  
visibility: 2nm

5062200

type: AS 500 - green - without bulb

5062210

type: AS 500 - green - 12V

5062220

type: AS 500 - green - 24V

**Signallaterne**  
Fassung BAY15d  
Sichtweite: 2sm

Typ: AS 500 - grün - ohne  
Glühlampe

Typ: AS 500 - grün - 12V

Typ: AS 500 - grün - 24V



**Signal Light**  
socket BAY15d  
visibility: 2nm

5062300

type: AS 500 - yellow - without bulb

5062310

type: AS 500 - yellow - 12V

5062320

type: AS 500 - yellow - 24V

**Signallaterne**  
Fassung BAY15d  
Sichtweite: 2sm

Typ: AS 500 - gelb - ohne  
Glühlampe

Typ: AS 500 - gelb - 12V

Typ: AS 500 - gelb - 24V



**Signal Light**  
socket BAY15d  
visibility: 2nm

5062400

type: AS 500 - blue - without bulb

5062410

type: AS 500 - blue - 12V

5062420

type: AS 500 - blue - 24V

**Signallaterne**  
Fassung BAY15d  
Sichtweite: 2sm

Typ: AS 500 - blau - ohne  
Glühlampe

Typ: AS 500 - blau - 12V

Typ: AS 500 - blau - 24V



**Signal Light**  
socket BAY15d  
hoistable  
visibility: 2nm

5072000

type: AS 507 - white reduced -  
without bulb

5072010

type: AS 507 - white reduced - 12V

5072020

type: AS 507 - white reduced - 24V

**Signallaterne**  
Fassung BAY15d  
heissbar  
Sichtweite: 2sm

Typ: AS 507 - weiß reduziert - ohne  
Glühlampe

Typ: AS 507 - weiß reduziert - 12V

Typ: AS 507 - weiß reduziert - 24V

Lanterns Type 500  
*Laternen Typ 500*



**Signal Light**  
 socket BAY15d  
 hoistable  
 visibility: 2nm

**5072100**

type: AS 507 - red - without bulb

**5072110**

type: AS 507 - red - 12V

**5072120**

type: AS 507 - red - 24V

**Signallaterne**  
 Fassung BAY15d  
 heissbar  
 Sichtweite: 2sm

Typ: AS 507 - rot - ohne Glühlampe

Typ: AS 507 - rot - 12V

Typ: AS 507 - rot - 24V



**Signal Light**  
 socket BAY15d  
 hoistable  
 visibility: 2nm

**5072200**

type: AS 507 - green - without bulb

**5072210**

type: AS 507 - green - 12V

**5072220**

type: AS 507 - green - 24V

**Signallaterne**  
 Fassung BAY15d  
 heissbar  
 Sichtweite: 2sm

Typ: AS 507 - grün - ohne Glühlampe

Typ: AS 507 - grün - 12V

Typ: AS 507 - grün - 24V



**Signal Light**  
 socket BAY15d  
 hoistable  
 visibility: 2nm

**5072400**

type: AS 507 - blue - without bulb

**5072410**

type: AS 507 - blue - 12V

**5072420**

type: AS 507 - blue - 24V

**Signallaterne**  
 Fassung: BAY15d  
 heissbar  
 Sichtweite: 2sm

Typ: AS 507 - blau - ohne Glühlampe

Typ: AS 507 - blau - 12V

Typ: AS 507 - blau - 24V



**Steering Light**  
 socket BA15d  
 visibility: 2nm

**5081000**

type: SL 500 - blue - without bulb

**Steuerlicht**  
 Fassung BA15d  
 Sichtweite: 2sm

Typ: SL 500 - blau - ohne Glühlampe

Lanterns Type 500  
*Laternen Typ 500*



**Socket**  
complete

5098000

BAY15d - for lantern type 500

**Fassung**  
komplett

BAY15d - für Laterne Typ 500



**Lens - white**  
spare part - complete

5098400

for lantern type T / AM 500

**Linse - weiß**  
Ersatzteil - komplett

für Laterne Typ T / AM 500



**Lens - white reduced**  
spare part - complete

5098500

for lantern type AS / H 500

**Linse - weiß reduziert**  
Ersatzteil - komplett

für Laterne Typ AS / H 500



**Lens - red**  
spare part - complete

5098600

for lantern type AS / SBb 500

**Linse - rot**  
Ersatzteil - komplett

für Laterne Typ AS / SBb 500



**Lens - green**  
spare part - complete

5098700

for lantern type AS / SSb 500

**Linse - grün**  
Ersatzteil - komplett

für Laterne Typ AS / SSb 500

Lanterns Type 500  
*Laternen Typ 500*



**Lens - yellow**  
spare part - complete

**5098800**

for lantern type AS / HS 500

**Linse - gelb**  
Ersatzteil - komplett

für Laterne Typ AS / HS 500



**Lens - blue**  
spare part - complete  
without DHI number

**5098900**

for lantern type AS / SL 500

**Linse - blau**  
Ersatzteil - komplett  
ohne DHI Nummer

für Laterne Typ AS / SL 500



# LED Navigation Lights, Type 580

for vessels < 50 m

## LED Navigationslaternen, Typ 580

für Schiffe < 50 m

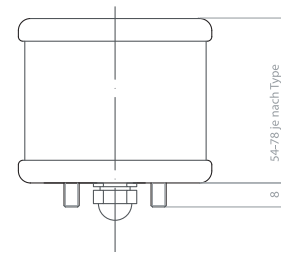
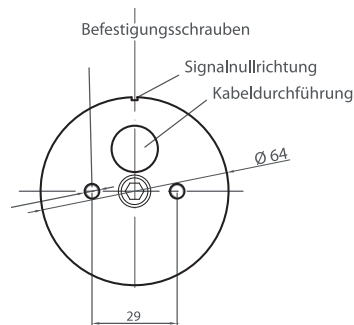

The navigation lanterns type 580 are developed for all vessels up to 50 m in length, according to International Regulations for Preventing Collisions at Sea 1972 (COLREGS 1972)

#### Advantages:

- Certified lifetime 20,000 hours
- Maintenance free
- Low power consumption
- No spare bulbs anymore
- Durable materials and great structural strength
- Shock resistant
- Non corrosive
- Seawater resistant
- Solar panel power supplies for 12 VDC stand alone systems available
- Solar/battery power supplies is available

#### Technical data:

**Approval:** BSH (Bundesamt für Seeschifffahrt und Hydrographie), GL (Germanischer Lloyd), UL 1104, MED

**Enclosure:** IP67/IP68

**Housing:** Black polyamid, glass fibre reinforced, shock resistant, non corrosive, non magnetic, seawater resistant, with stainless steel screens (1.4571)

**Marine cable:** 1.5 m

*Die Laterne Typ 580 für alle Schiffe bis 50m, in Übereinstimmung mit der COLREG 1972*

#### Vorteile:

- *Garantierte Lebensdauer von 20.000 Stunden*
- *Wartungsfrei*
- *Sparsamer Verbrauch*
- *Keine Ersatzglühlampen mehr*
- *Haltbare Materialien und stabile Konstruktion*
- *Sehr robust, vibrationsfest*
- *Rostfrei*
- *Salzwasserresistent*
- *Solar/Batteriebetrieb möglich*
- *Verkabelt, daher sofort anschlussbereit*

#### Technische Daten:

**Zulassungen:** BSH (Bundesamt für Seeschifffahrt und Hydrographie), GL (Germanischer Lloyd), UL 1104, MED

**Schutzart:** IP67/IP68

**Gehäuse:** Schwarzes, glasfaserverstärktes Polyamid, korrosionsfrei, schocksicher, seewasserbeständig, antimagnetisch, Blenden aus Edelstahl (1.4571)

**Anschlußkabel:** 1,5 m

Lanterns LED Type 580  
*Laternen LED Typ 580*



**LED - Side Light**  
 hard coated, black  
 incl. bracket, cable  
 9-28 Volt - DC  
 visibility: 2nm  
 power consumption: 1,8 Watt

5091200

type: SSb 580 - green

**LED - Seitenlaterne**  
 hart eloxiert, schwarz  
 inkl. Halter, Kabel  
 9-28 Volt - DC  
 Sichtweite: 2sm  
 Leistungsaufnahme: 1,8 Watt

Typ: SSb 580 - grün



**LED - Double Side Light**  
 hard coated, black  
 incl. bracket, cable  
 9-28 Volt - DC  
 visibility: 2nm  
 power consumption: 3 Watt

5091210

type: TD 580 - red / green

**LED - Doppelseitenlaterne**  
 hart eloxiert, schwarz  
 inkl. Halter, Kabel  
 9-28 Volt - DC  
 Sichtweite: 2sm  
 Leistungsaufnahme: 3 Watt

Typ: TD 580 - rot / grün



**LED - Side Light**  
 hard coated, silver  
 incl. bracket, cable  
 9-28 Volt - DC  
 visibility: 2nm  
 power consumption: 1,8 Watt

5091216

type: SSb 580 - green

**LED - Seitenlaterne**  
 hart eloxiert, silber  
 inkl. Halter, Kabel  
 9-28 Volt - DC  
 Sichtweite: 2sm  
 Leistungsaufnahme: 1,8 Watt

Typ: SSb 580 - grün



**LED - Side Light**  
 hard coated, black  
 incl. bracket, cable  
 9-28 Volt - DC  
 visibility: 2nm  
 power consumption: 1,2 Watt

5091300

type: SBb 580 - red

**LED - Seitenlaterne**  
 hart eloxiert, schwarz  
 inkl. Halter, Kabel  
 9-28 Volt - DC  
 Sichtweite: 2sm  
 Leistungsaufnahme: 1,2 Watt

Typ: SBb 580 - rot



**LED - Side Light**  
 hard coated, silver  
 incl. bracket, cable  
 9-28 Volt - DC  
 visibility: 2nm  
 power consumption: 1,2 Watt

5091310

type: SBb 580 - red

**LED - Seitenlaterne**  
 hart eloxiert, silber  
 inkl. Halter, Kabel  
 9-28 Volt - DC  
 Sichtweite: 2sm  
 Leistungsaufnahme: 1,2 Watt

Typ: SBb 580 - rot



**LED - Stern Light**  
 hard coated, black  
 incl. bracket, cable  
 9-28 Volt - DC  
 visibility: 2nm  
 power consumption: 2,1 Watt

5091400

type: H 580 - white

**LED - Hecklaterne**  
 hart eloxiert, schwarz  
 inkl. Halter, Kabel  
 9-28 Volt - DC  
 Sichtweite: 2sm  
 Leistungsaufnahme: 2,1 Watt

Typ: H 580 - weiß

Lanterns LED Type 580  
*Laternen LED Typ 580*



**LED - Stern Towing Light**  
hard coated, schwarz  
incl. bracket, cable  
9-28 Volt - DC  
visibility: 2nm  
power consumption: 2,1 Watt

5091410

type: HS 580 - yellow

**LED - Heck -  
Schlepplaterne**  
hart eloxiert, schwarz  
inkl. Halter, Kabel  
9-28 Volt - DC  
Sichtweite: 2sm  
Leistungsaufnahme: 2,1 Watt

Typ: HS 580 - gelb



**LED - Stern Light**  
hard coated, silver  
incl. bracket, cable  
9-28 Volt - DC  
visibility: 2nm  
power consumption: 2,1 Watt

5091416

type: H 580 - white

**LED - Hecklaterne**  
hart eloxiert, silber  
inkl. Halter, Kabel  
9-28 Volt - DC  
Sichtweite: 2sm  
Leistungsaufnahme: 2,1 Watt

Typ: H 580 - weiß



**LED - Stern Towing Light**  
hard coated, silver  
incl. bracket, cable  
9-28 Volt - DC  
visibility: 2nm  
power consumption: 2,1 Watt

5091418

type: HS 580 - yellow

**LED - Heck -  
Schlepplaterne**  
hart eloxiert, silber  
inkl. Halter, Kabel  
9-28 Volt - DC  
Sichtweite: 2sm  
Leistungsaufnahme: 2,1 Watt

Typ: HS 580 - gelb



**LED - Masthead Light**  
hard coated, black  
incl. bracket, cable  
9-28 Volt - DC  
visibility: 3nm  
power consumption: 7,5 Watt  
only for vessels <20m in lenth

5091500

type: T 580 - 3nm - white

**LED - Toplaterne**  
hart eloxiert, schwarz  
inkl. Halter, Kabel  
9-28 Volt - DC  
Sichtweite: 3sm  
Leistungsaufnahme: 7,5 Watt  
nur für Schiffe < 20m Länge

Typ: T 580 - 3sm - weiß



**LED - Masthead Light**  
hard coated, silver  
incl. bracket, cable  
9-28 Volt - DC  
visibility: 3nm  
power consumption: 7,5 Watt  
only for vessels <20m in lenth

5091510

type: T 580 - 3nm - white

**LED - Toplaterne**  
hart eloxiert, silber  
inkl. Halter, Kabel  
9-28 Volt - DC  
Sichtweite: 3sm  
Leistungsaufnahme: 7,5 Watt  
nur für Schiffe < 20m Länge

Typ: T 580 - 3sm - silber

Lanterns LED Type 580  
Laterne LED Typ 580



**LED - Masthead Light**  
hard coated, black  
incl. bracket, cable  
24-28 Volt - DC  
visibility: 5sm  
power consumption: 11 Watt  
only for vessels > 20m in length

5091550

type: T 580 - 5nm - white

**LED - Topplaterne**  
hart eloxiert, schwarz  
inkl. Halter, Kabel  
24-28 Volt - DC  
Sichtweite: 5sm  
Leistungsaufnahme: 11 Watt  
nur für Schiffe > 20m Länge

Typ: T 580 - weiß



**LED - Masthead Light**  
hard coated, silver  
incl. bracket, cable  
24-28 Volt - DC  
visibility: 5sm  
power consumption: 11 Watt  
only for vessels > 20m in length

5091556

type: T 580 - 5nm - white

**LED - Topplaterne**  
hart eloxiert, silber  
inkl. Halter, Kabel  
24-28 Volt - DC  
Sichtweite: 5sm  
Leistungsaufnahme: 11 Watt  
nur für Schiffe > 20m Länge

Typ: T 580 - weiß



**LED - Signal Light**  
hard coated, black  
incl. bracket, cable  
9-28 Volt - DC  
visibility: 2nm  
power consumption: 2,8 Watt

5091600

type: AS 580 - white

**LED - Signallaterne**  
hart eloxiert, schwarz  
inkl. Halter, Kabel  
9-28 Volt - DC  
Sichtweite: 2sm  
Leistungsaufnahme: 2,8 Watt

Typ: AS 580 - weiß



**LED - Signal Light**  
brass  
incl. bracket, cable  
9-28 Volt - DC  
visibility: 2nm  
power consumption: 2,8 Watt

5091604

type: AS 580 - white

**LED - Signallaterne**  
Messing  
inkl. Halter und Kabel  
9-28 Volt - DC  
Sichtweite: 2sm  
Leistungsaufnahme: 2,8 Watt

Typ: AS 580 - weiß



**LED - Signal Light**  
hard coated, silver  
incl. bracket, cable  
9-28 Volt - DC  
visibility: 2nm  
power consumption: 2,8 Watt

5091610

type: AS 580 - white

**LED - Signallaterne**  
hart eloxiert, silber  
inkl. Halter, Kabel  
9-28 Volt - DC  
Sichtweite: 2sm  
Leistungsaufnahme: 2,8 Watt

Typ: AS 580 - weiß





Lanterns LED Type 580  
Laternen LED Typ 580

**LED - Signal Light**  
hard coated, black  
incl. bracket, cable  
9-28 Volt - DC  
visibility: 2nm  
power consumption: 1,8 Watt

5091700

type: AS 580 - red

**LED - Signallaterne**  
hart eloxiert, schwarz  
inkl. Halter, Kabel  
9-28 Volt - DC  
Sichtweite: 2sm  
Leistungsaufnahme: 1,8 Watt

Typ: AS 580 - rot



**LED - Signal Light**  
hard coated, silver  
incl. bracket, cable  
9-28 Volt - DC  
visibility: 2nm  
power consumption: 1,8 Watt

5091706

type: AS 580 - red

**LED - Signallaterne**  
hart eloxiert, silber  
inkl. Halter, Kabel  
9-28 Volt - DC  
Sichtweite: 2sm  
Leistungsaufnahme: 1,8 Watt

Typ: AS 580 - rot



**LED - Signal Light**  
hard coated, black  
incl. bracket, cable  
9-28 Volt - DC  
visibility: 2nm  
power consumption: 3,6 Watt

5091800

type: AS 580 - yellow

5091806

type: AS 580 - yellow - flash

**LED - Signallaterne**  
hart eloxiert, schwarz  
inkl. Halter, Kabel  
9-28 Volt - DC  
Sichtweite: 2sm  
Leistungsaufnahme: 3,6 Watt

Typ: AS 580 - gelb

Typ: AS 580 - gelb - Blitz



**LED - Signal Light**  
hard coated, black  
incl. bracket, cable  
9-28 Volt - DC  
visibility: 2nm  
power consumption: 2,7 Watt

5091810

type: AS 580 - green

**LED - Signallaterne**  
hart eloxiert, schwarz  
inkl. Halter, Kabel  
9-28 Volt - DC  
Sichtweite: 2sm  
Leistungsaufnahme: 2,7 Watt

Typ: AS 580 - grün



**LED - Signal Light**  
hard coated, silver  
incl. bracket, cable  
9-28 Volt - DC  
visibility: 2nm  
power consumption: 2,7 Watt

5091818

type: AS 580 - green

**LED - Signallaterne**  
hart eloxiert, silber  
inkl. Halter, Kabel  
9-28 Volt - DC  
Sichtweite: 2sm  
Leistungsaufnahme: 2,7 Watt

Typ: AS 580 - grün

Lanterns LED Type 580  
*Laternen LED Typ 580*



**LED - Signal Light**  
 hard coated, black  
 incl. bracket, cable  
 9-28 Volt - DC  
 visibility: 2nm  
 power consumption: 2,8 Watt

5091820

type: AS 580 - blue

5091823

type: AS 580 - blue - flash

**LED - Signallaterne**  
 hart eloxiert, schwarz  
 inkl. Halter, Kabel  
 9-28 Volt - DC  
 Sichtweite: 2sm  
 Leistungsaufnahme: 2,8 Watt

Typ: AS 580 - blau

Typ: AS 580 - blau - Blitz



**LED - Tri-Color Light**  
 hard coated, silver  
 incl. bracket, cable  
 9-28 Volt - DC  
 visibility: 2nm  
 power consumption: 2,8 Watt

5091836

type: AD 580 - white / red / green

**LED - Seglerlaterne**  
 hart eloxiert, silber  
 inkl. Halter, Kabel  
 9-28 Volt - DC  
 Sichtweite: 2sm  
 Leistungsaufnahme: 2,8 Watt

Typ: AD 580 - weiß / rot / grün



**LED - Combi Light**  
 hard coated, black  
 incl. bracket, cable  
 9-28 Volt - DC  
 visibility: 2nm  
 power consumption: 2,8 Watt

5091840

type: ADA 580 - white / red-green-white

**LED - Kombilaterne**  
 hart eloxiert, schwarz  
 inkl. Halter, Kabel  
 9-28 Volt - DC  
 Sichtweite: 2sm  
 Leistungsaufnahme: 2,8 Watt

Typ: ADA 580 - weiß / rot-weiß-grün



**LED - Combi Light**  
 brass  
 incl. bracket, cable  
 9-28 Volt - DC  
 visibility: 2nm  
 power consumption: 2,8 Watt

5091844

type: ADA 580 - white / red-green-white

**LED - Kombilaterne**  
 Messing  
 inkl. Halter und Kabel  
 9-28 Volt - DC  
 Sichtweite: 2sm  
 Leistungsaufnahme: 2,8 Watt

Typ: ADA 580 - weiß / rot-weiß-grün



**LED - Combi Light**  
 hard coated, silver  
 incl. bracket, cable  
 9-28 Volt - DC  
 visibility: 2nm  
 power consumption: 2,8 Watt

5091846

type: ADA 580 - white / red-green-white

**LED - Kombilaterne**  
 hart eloxiert, silber  
 inkl. Halter, Kabel  
 9-28 Volt - DC  
 Sichtweite: 2sm  
 Leistungsaufnahme: 2,8 Watt

Typ: ADA 580 - weiß / rot-weiß-grün

Lanterns LED Type 580  
*Laternen LED Typ 580*



**LED - Combi Light - with Windexlight**

hard coated, anthrazid  
incl. bracket, cable 1,5m  
9-28 Volt - DC  
visibility: 2nm  
power consumption: 2,8 Watt

power consumption: 3,4 W  
light intensity: 80 lx/m.

without Windex

**5092000**

type: ADA 580 - white / red-green-white

**LED - Kombilaterne - mit Windexleuchte**

hart eloxiert, anthrazit  
inkl. Halter, Kabel 1,5m  
9-28 Volt - DC  
Sichtweite: 2sm  
Leistungsaufnahme: 2,8 Watt

Windexleuchte:  
Leistungsaufnahme: 3,5 W  
Leuchtstärke: ca. 80 lx/m

ohne Windex

Typ: ADA-W 580 - weiß / rot-weiß-grün



**Mastbracket - complete**

consisting of:  
mast mounting plate - silver  
T 580 - 3nm silver anodizes  
BWL 50 - silver anodizes

**5800253**

for lantern T 580 / BWL50

**Masthalterung - komplett**

bestehend aus:  
Masthalterung - silber  
T 580 - 3sm silber eloxiert  
BWL 50 - silber eloxiert

für Laterne T 580 / BWL 50



**Mastbracket - complete**

consisting of: mast mounting plate - black  
T 580 - 3nm - black anodizes  
BWL 50 - black anodizes

**5800254**

for lantern T 580 / BWL50

**Masthalterung - komplett**

bestehend aus: Masthalterung - schwarz  
T 580 - 3sm - schwarz eloxiert  
BWL 50 - schwarz eloxiert

für Laterne T 580 / BWL 50



**Mastbracket - complete**

consisting of: mast mounting plate - white  
T 580 - 3nm silver anodizes  
BWL 50 - silver anodizes

**5800257**

for lantern T 580 / BWL50

**Masthalterung - komplett**

bestehend aus: Masthalterung - weiß  
T 580 - 3sm silber eloxiert  
BWL 50 - silber eloxiert

für Laterne T 580 / BWL 50

Lanterns LED Type 580  
*Laternen LED Typ 580*



**Mastbracket - complete**

consisting of:  
Mast mounting plate - white  
T 580 - silver anodizes  
BWL 50 - silver anodizes

**5800256**

for lantern T 580 / BWL50

**Masthalterung - komplett**

bestehend aus:  
Masthalterung - weiß  
T 580 - silber eloxiert  
BWL 50 - silber- eloxiert

für Laterne T580 5sm/BWL50



**Mastbracket - complete**

consisting of:  
Mast mounting plate - silver  
T 580 - silver anodizes  
BWL 50 - silver anodizes

**5800258**

for lantern T 580 / BWL50

**Masthalterung - komplett**

bestehend aus:  
Masthalterung - silber  
T 580 - silber eloxiert  
BWL 50 - silber- eloxiert

für Laterne T580 5sm/BWL50



**Mastbracket - complete**

consisting of:  
mast mounting plate - black  
T 580 - 5nm - black anodizes  
BWL 50 - black anodizes

**5800245**

for lantern T 580 5nm / BWL50

**Masthalterung - komplett**

bestehend aus:  
Masthalterung - schwarz  
T 580 - 5sm - schwarz eloxiert  
BWL 50 - schwarz eloxiert

für Laterne T 580 5sm / BWL 50





Flash Lights Xenon  
*Blitzleuchten - Xenon*

**Xenon Flash Light**  
60/120/180 flashes / minutes  
visibility: 3 nautical miles

1128890

yellow - 115V AC

1128900

yellow - 230V AC

**Xenon - Blitzleuchte**  
60/120/180 Blitze / Minute  
Sichtweite: 3 Seemeilen

gelb - 115V AC

gelb - 230V AC



**Xenon Flash Light**  
60/120/180 flashes / minutes  
visibility: 3 nautical miles

1128990

green - 115V AC

1129000

green - 230V AC

**Xenon - Blitzleuchte**  
60/120/180 Blitze / Minute  
Sichtweite: 3 Seemeilen

grün - 115V AC

grün - 230V AC



**Xenon Flash Light**  
60/120/180 flashes / minutes  
visibility: 3 nautical miles

1129080

red - 115V AC

1129100

red - 230V AC

**Xenon - Blitzleuchte**  
60/120/180 Blitze / Minute  
Sichtweite: 3 Seemeilen

rot - 115V AC

rot - 230V AC

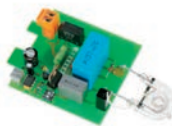

**Xenon Flash Insert**  
60/120/180 flashes / minutes

1128600

115V AC

1128800

230V AC

**Xenon - Einsatz**  
60/120/180 Blitze / Minute

115V AC

230V AC

Flash Lights LED  
*Blitzleuchten - LED*



**LED Flash Light**

visibility: 3 nautical miles

**1128910**

yellow - 230V AC - 60 1/min

**1128915**

white - 115V AC - 60 1/min

**1128920**

yellow - 24V DC - 60 1/min

**1128922**

yellow - 12V DC - 60 1/min

**1129010**

green - 230V AC - 180 1/min

**1129020**

green - 24V DC - 180 1/min

**1129110**

red - 230V AC - 120 1/min

**1129115**

red - 115/120V AC - 120 1/min

**1129120**

red - 24V DC - 120 1/min

**LED Blitzleuchte**

Sichtweite: 3 Seemeilen

gelb - 230V AC - 60 1/min

weiß - 115V AC - 60 1/min

gelb - 24V DC - 60 1/min

gelb - 12V DC - 60 1/min

grün - 230V AC - 180 1/min

grün - 24V DC - 180 1/min

rot - 230V AC - 120 1/min

rot - 115/120V AC - 120 1/min

rot - 24V DC - 120 1/min

LED Signal Lights  
*LED-Signalleuchten*



**LED Obstruction Light**

visibility: 3 nautical miles  
power consumption: 9 Watt  
with ICAO approval

**1129150**

red - 230V AC

**1129151**

red - 12V DC

**1129154**

red - 24V DC

**LED Hindernisfeuer**

Sichtweite: 3 Seemeilen  
Leistungsaufnahme: 9 Watt  
mit ICAO Zulassung

rot - 230V - AC

rot - 12V - DC

rot - 24V - DC



LED Signal Lights  
*LED-Signalleuchten*

**LED Signal Light**  
visibility: 3 nautical miles  
power consumption: 8 Watt

2411350

white - 230V AC

2412350

green - 230V AC

2413350

red - 230V AC

2413351

red - 115/120V AC

2414350

yellow - 230V AC

2415350

blue - 230V AC

**LED Signalleuchte**  
Sichtweite: 3 Seemeilen  
Leistungsaufnahme: 8 Watt

weiß - 230V AC

grün - 230V AC

rot - 230V AC

rot - 115/120V AC

gelb - 230V AC

blau - 230V AC



Signal Lights  
*Signalleuchten*

**Signal Light**  
socket E27

2411000

white - upright - lens

**Signalleuchte**  
Fassung E27

weiß - stehend - Linse



**Signal Light**  
socket E27

2411100

white - upright - glassbell

**Signalleuchte**  
Fassung E27

weiß - stehend - Sturzglas

Signal Lights  
*Signalleuchten*



**Signal Light**  
socket E27

2412000

green - upright - lens

**Signalleuchte**  
Fassung E27

grün - stehend - Linse



**Signal Light**  
socket E27

2412100

green - upright - glassbell

**Signalleuchte**  
Fassung E27

grün - stehend - Sturzglas



**Signal Light**  
socket E27

2413000

red - upright - lens

**Signalleuchte**  
Fassung E27

rot - stehend - Linse



**Signal Light**  
socket E27

2413100

red - upright - glassbell

**Signalleuchte**  
Fassung E27

rot - stehend - Sturzglas





Signal Lights  
*Signalleuchten*

**Signal Light**  
socket E27

2414000

yellow - upright - lens

**Signalleuchte**  
Fassung E27

gelb - stehend - Linse



**Signal Light**  
socket E27

2414100

yellow - upright - glassbell

**Signalleuchte**  
Fassung E27

gelb - stehend - Sturzglas



**Signal Light**  
socket E27

2415100

blue - upright - glassbell

**Signalleuchte**  
Fassung E27

blau - stehend - Sturzglas

Spareparts  
*Ersatzteile*



**Socket**  
brass

2419100

B22 - 2 feet flange

**Fassung**  
Messing

Zweibock - B22

Spareparts  
Ersatzteile



**Socket**  
brass

2419110

E27 - 2 feet flange

**Fassung**  
Messing

Zweibock - E27



**Glassbell**  
for signal light

2499000

4 x 3,5" - white

**Sturzglas - Linsenform**  
für Signalleuchte

4 x 3,5" - weiß



**Glassbell**  
for signal light

2499100

4 x 3,5" - green

**Sturzglas - Linsenform**  
für Signalleuchte

4 x 3,5" - grün



**Glassbell**  
for signal light

2499200

4 x 3,5" - red

**Sturzglas - Linsenform**  
für Signalleuchte

4 x 3,5" - rot



**Glassbell**  
for signal light

2499300

4 x 3,5" - yellow

**Sturzglas - Linsenform**  
für Signalleuchte

4 x 3,5" - gelb



Spareparts  
Ersatzteile

**Glassbell**  
for signal light

2499500

94 x 115mm - white

**Sturzglas**  
für Signalleuchte

94 x 115mm - weiß



**Glassbell**  
for signal light

2499600

94 x 115mm - red

**Sturzglas**  
für Signalleuchte

94 x 115mm - rot



**Glassbell**  
for signal light

2499700

94 x 115mm - green

**Sturzglas**  
für Signalleuchte

94 x 115mm - grün



**Glassbell**  
for signal light

2499800

94 x 115mm - yellow

**Sturzglas**  
für Signalleuchte

94 x 115mm - gelb



**Glassbell**  
for signal light

2499900

94 x 115mm - blue

**Sturzglas**  
für Signalleuchte

94 x 115mm - blau

# Navigation Lights for Vessels < 20 m

## *Navigationslaternen für Schiffe < 20 m*



- IP56
- All lights will be delivered with bulb
- Dust and water protection
- All lights are weatherproof
- High quality polycarbonate lenses
- Long life

- IP56
- *Alle Laternen werden mit Glühlampe geliefert*
- *Staub- und wassergeschützt*
- *Alle Laternen sind witterungsbeständig*
- *Qualitativ hochwertige Polycarbonat Linsen*
- *Lange Lebensdauer*

**Approvals:** BSH (Bundesamt für Seeschifffahrt und Hydrographie), MED

**Zulassungen:** BSH (Bundesamt für Seeschifffahrt und Hydrographie), MED

### Type 410, Typ 410

- Backplate fixed assembly
- Stainless steel
- *Rückwand-Festmontage*
- *Edelstahlgehäuse*

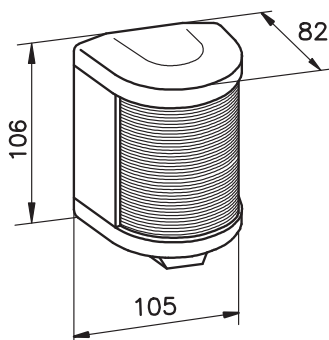

### Type 431, Typ 431

- Socked fixed assembly
- Stainless steel
- *Sockel-Festmontage*
- *Edelstahlgehäuse*

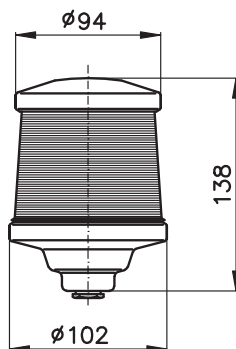

### Type 400, Typ 400

- Hoistable
- Stainless steel
- *Aufheizbar*
- *Edelstahlgehäuse*

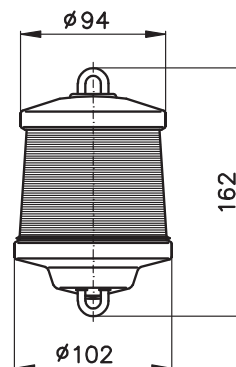



Type 420, Typ 420

- Base fixed assembly
- Polycarbonate
- Rückwand-Festmontage
- Polycarbonat

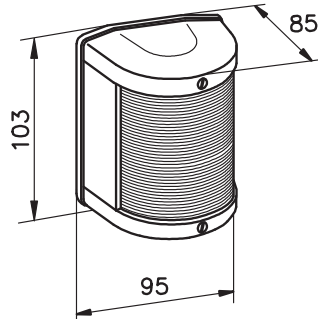

Type 421, Typ 421

- Mounting hook
- Polycarbonate
- Mit Aufsteckhaken
- Polycarbonat

Type 422, Typ 422

- Base fixed assembly
- Stainless steel screens, bottom, cover
- Polycarbonate backplate in white
- Rückwand-Festmontage
- Blenden, Deckel und Boden aus Edelstahl
- Polycarbonate Rückwand in weiss

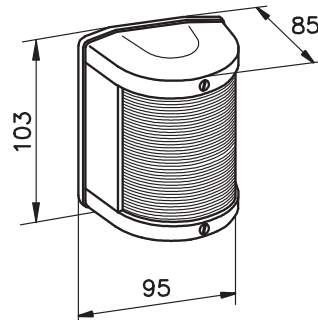

Type 423, Typ 423

- Mounting hook
- Stainless steel screens, bottom, cover
- Polycarbonate backplate in white
- Mit Aufsteckhaken
- Rückwand-Festmontage
- Blenden, Deckel und Boden aus Edelstahl

Type 426, Typ 426

- Base fixed assembly
- Polycarbonate
- Sockel-Festmontage
- Polycarbonat

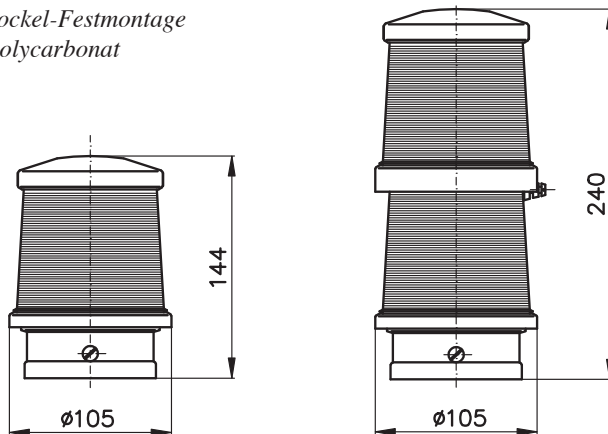

Type 427, Typ 427

- Hoistable
- Polycarbonate
- Aufheizbar
- Polycarbonat

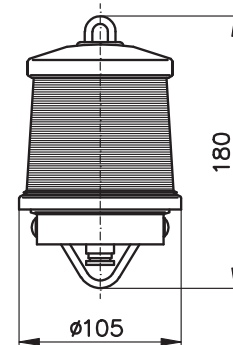

Lanterns Type 410  
*Laternen Typ 410*

**Side Light**

socket BAY15d  
without bulb  
visibility: 2nm

4011201

type: SSb 410 - green



**Seitenlaterne**

Fassung BAY15d  
ohne Leuchtmittel  
Sichtweite: 2sm

Typ: SSb 410 - grün

**Side Light**

socket BAY15d  
without bulb  
visibility: 2nm

4021201

type: SBb 410 - red



**Seitenlaterne**

Fassung BAY15d  
ohne Leuchtmittel  
Sichtweite: 3sm

Typ: SBb 410 - rot

**Masthead Light**

socket BAY15d  
without bulb  
visibility: 3nm

4031201

type: T 410 - white



**Toplaterne**

Fassung BAY15d  
ohne Leuchtmittel  
Sichtweite: 3sm

Typ: T 410 - weiß

**Stern Light**

socket BAY15d  
without bulb  
visibility: 2nm

4041201

type: H 410 - white



**Hecklaterne**

Fassung BAY15d  
ohne Leuchtmittel  
Sichtweite: 2sm

Typ: H 410 - weiß



Lanterns Type 410  
*Laternen Typ 410*

**Double Side Light**  
socket BAY15d  
without bulb  
visibility: 2nm

4051201

type: TD 410 - red/green

**Doppel - Seitenlaterne**  
Fassung BAY15d  
ohne Leuchtmittel  
Sichtweite: 2sm

Typ: TD 410 - rot/grün

**Light Insert**

4095000

for lantern type 410 - complete

**Lichteinsatz**

für Laternen Typ 410 - komplett

**Socket**  
for lantern type 410

4095300

BAY15d complete with screws

**Fassung**  
für Laterne Typ 410

BAY15d - komplett - mit Schrauben

**Lens**

4096000

for T / H 410 - white

**Linse**

für T / H 410 - weiß

**Lens**

4096100

for SSb 410 - green

**Linse**

für SSb 410 - grün

**Lens**

4096200

for SBb 410 - red

**Linse**

für SBb 410 - rot

**Lens**

4096300

for TD 410 - red/green

**Linse**

für TD 410 - rot/grün

Lanterns Type 410  
Laterne Typ 410



**Pop rivet**  
4 pieces per package  
**4096500**  
for spare lens type 410

**Popnieten**  
Paket a 4 Stück  
  
für Ersatzlinse Typ 410



**Mounting Plate - Mast**  
aluminium  
**4081000**  
for lantern type 410 / 420

**Montageplatte - Mast**  
Aluminium  
  
für Laterne Typ 410 / 420



**Mounting Plate 1**  
stainless steel  
**4081100**  
for lantern type 410

**Montageplatte 1**  
Edelstahl  
  
für Laterne Typ 410



**Mounting Plate 3**  
stainless steel  
**4081300**  
for lantern type 410

**Montageplatte 3**  
Edelstahl  
  
für Laterne Typ 410



**Mounting Plate 4**  
stainless steel  
**4081400**  
for lantern type 410

**Montageplatte 4**  
Edelstahl  
  
für Laterne Typ 410



**Plug Connection**  
plug + socket  
chrom plated  
**4082000**  
2 - pole

**Steckverbindung**  
Stecker + Steckdose  
verchromt  
  
2 - polig



**Plug**  
chrom plated  
**4082100**  
2-pole

**Stecker**  
verchromt  
  
2 - polig



**Female Socket**  
chrom plated  
**4082200**  
2 - pole

**Steckdose**  
verchromt  
  
2 - polig



Lanterns Type 410  
*Laternen Typ 410*



**Plug Connection**  
plug + socket  
chrom plaited

4083000

3 - pole

**Steckverbindung**  
Stecker + Steckdose  
verchromt

3 - polig



**Plug**  
chrom plaited

4083100

3 - pole

**Stecker**  
verchromt

3 - polig



**Female Socket**  
chrom plaited

4083200

3 - pole

**Steckdose**  
verchromt

3 - polig



**Alternate Angle**  
stainless steel - complete

4085000

for lantern type 410

**Wechselwinkel**  
Edelstahl komplett

für Laterne Typ 410



**Mounting Hook**  
stainless steel

4099000

short - for lantern type 410

**Aufsteckhaken**  
Edelstahl

kurz - für Laterne Typ 410



**Mounting Hook**  
stainless steel

4099100

long - for lantern type 410

**Aufsteckhaken**  
Edelstahl

lang - für Laterne Typ 410

Lanterns Type 420/422  
Laternen Typ 420/422



**Side Light**

socket BAY15d  
without bulb  
fixed assembly  
visibility: 2nm

4210199

type: SSb 420 - green

**Seitenlaterne**

Fassung BAY15d  
ohne Glühlampe  
Festmontage  
Sichtweite: 2sm

Typ: SSb 420 - grün



**Side Light**

socket BAY15d  
without bulb  
fixed assembly  
visibility: 2nm

4220299

type: SBb 420 - red

**Seitenlaterne**

Fassung BAY15d  
ohne Glühlampe  
Festmontage  
Sichtweite: 2sm

Typ: SBb 420 - rot



**Masthead Light**

socket BAY15d  
without bulb  
fixed assembly  
visibility: 3nm

4230299

type: T 420 - white

**Topplaterne**

Fassung BAY15d  
ohne Glühlampe  
Festmontage  
Sichtweite: 3sm

Typ: T 420 - weiß



**Stern Light**

socket BAY15d  
without bulb  
fixed assembly  
visibility: 2nm

4240299

type: H 420 - white

**Hecklaterne**

Fassung BAY15d  
ohne Glühlampe  
Festmontage  
Sichtweite: 2sm

Typ: H 420 - weiß

Lanterns Type 420/422  
Laternen Typ 420/422



**Stern - Towing Light**

socket BAY15d  
without bulb  
fixed assembly  
visibility: 2nm

4243299

type: HS 420 - yellow

**Heck - Schlepplaterne**

Fassung BAY15d  
ohne Glühlampe  
Festmontage  
Sichtweite: 2sm

Typ: HS 420 - gelb



**Spare Lens - green**

complete  
with cover, bottom and screws

4219000

for sidelight - SSb 420/421

**Ersatzlinse - grün**

komplett  
mit Deckel, Boden und Schrauben

für Seitenlaterne - SSb 420/421



**Spare Lens - red**

complete  
with cover, bottom and screws

4229000

for sidelight - SBb 420 / 421

**Ersatzlinse - rot**

komplett  
mit Deckel, Boden und Schrauben

für Seitenlaterne - SBb 420/421



**Spare Lens - white**

complete  
with cover, bottom and screws

4239000

for mastheadlight - T 420/421

**Ersatzlinse - weiß**

komplett  
mit Deckel, Boden und Schrauben

für Toplaterne - T 420/421



**Spare Lens - red/green**

complete  
with cover, bottom and screws

4259000

for double-sidelight - TD 420/421

**Ersatzlinse - rot/grün**

komplett  
mit Deckel, Boden und Schrauben

für Doppelseitenlaterne - TD 420/421



**Masthead Light**

socket BAY15d  
without bulb  
fixed assembly  
stainless steel cover and bottom  
visibility: 3nm

4233200

type: T 422 - white

**Toplaterne**

Fassung BAY15d  
ohne Glühlampe  
Festmontage  
Deckel und Boden aus Edelstahl  
Sichtweite: 3sm

Typ: T 422 - weiß

Lanterns Type 420/422  
*Laternen Typ 420/422*



**Stern - Towing Light**

socket BAY15d  
 without bulb  
 fixed assembly  
 stainless steel cover and bottom  
 visibility: 2nm

4242299

type: HS 422 - yellow - socket BAY15d

**Heck - Schlepplaterne**

Fassung BAY15d  
 ohne Glühlampe  
 Festmontage  
 Deckel und Boden aus Edelstahl  
 Sichtweite: 2sm

Typ: HS 422 - gelb



**Stern Light**

socket BAY15d  
 without bulb  
 fixed assembly  
 stainless steel cover and bottom  
 visibility: 2nm

4242800

type: H 422 - white

**Hecklaterne**

Fassung BAY15d  
 ohne Glühlampe  
 Festmontage  
 Deckel und Boden aus Edelstahl  
 Sichtweite: 2sm

Typ: H 422 - weiß



**Double Side Light**

socket BAY15d  
 without bulb  
 fixed assembly  
 stainless steel cover and bottom  
 visibility: 2nm

4253200

type: TD 422 - red / green

**Doppelfarbige Seitenlaterne**

Fassung BAY15d  
 ohne Glühlampe  
 Festmontage  
 Deckel und Boden aus Edelstahl  
 Sichtweite: 2sm

Typ: TD 422 - rot / grün



**Spare Lens - green**  
 with gaskets

4219010

for sidelight SSb 422/423

**Ersatzlinse - grün**  
 inklusive Dichtungen

für Seitenlaterne SSb 422/423



**Spare Lens - red**  
 with gaskets

4229010

for sidelight SBb 422/423

**Ersatzlinse - rot**  
 inklusive Dichtungen

für Seitenlaterne SBb 422/423



**Spare Lens - white**  
 with gaskets

4239010

for masthead- / sternlight 422/423

**Ersatzlinse - weiß**  
 inklusive Dichtungen

für Topp- / Hecklaterne T/H 422/423



**Spare Lens - red/green**  
 with gaskets

4259010

for double-side light - TD 422

**Ersatzlinse - rot/grün**  
 inklusive Dichtungen

für Doppelseitenlaterne - TD 422/423





Lanterns Type 420/422  
*Laternen Typ 420/422*

**Mounting Plate 1**  
stainless steel

4081110

for lantern type 420

**Montageplatte 1**  
Edelstahl

für Laternen Typ 420

**Mounting Plate 2**  
stainless steel

4081210

for lantern type 420

**Montageplatte 2**  
Edelstahl

für Laternen Typ 420

**Mounting Hook - long**  
stainless steel

4297900

for lantern type 421 / 423

**Aufsteckhaken - lang**  
Edelstahl

für Laterne Typ 421 / 423

**Mounting Hook Set**

4298100

for lantern type 420/422

**Aufsteckhaken Set**

für Laternen Typ 420 / 422

**Alternate Angle**  
stainless steel - complete

4298510

for lantern type 421 / 423

**Wechselwinkel**  
Edelstahl - komplett

für Laterne Typ 421 / 423

Lanterns Type 426  
 Laternen Typ 426



**Anchor Light**  
 socket BAY15d  
 without bulb  
 fixed assembly  
 visibility: 2nm

4261400

type: A 426 - white

**Ankerlaterne**  
 Fassung BAY15d  
 ohne Glühlampe  
 Festmontage  
 Sichtweite: 2sm

Typ: A 426 - weiß



**Signal Light**  
 socket BAY15d  
 without bulb  
 fixed assembly  
 visibility: 2nm

4262400

type: AS 426 - red

**Signallaterne**  
 Fassung BAY15d  
 ohne Glühlampe  
 Festmontage  
 Sichtweite: 2sm

Typ: AS 426 - rot



**Signal Light**  
 socket BAY15d  
 without bulb  
 fixed assembly  
 visibility: 2nm

4263400

type: AS 426 - green

**Signallaterne**  
 Fassung BAY15d  
 ohne Glühlampe  
 Festmontage  
 Sichtweite: 2sm

Typ: AS 426 - grün



**Signal Light**  
 socket BAY15d  
 without bulb  
 fixed assembly  
 visibility: 2nm

4263700

type: AS 426 - blue

**Signallaterne**  
 Fassung BAY15d  
 ohne Glühlampe  
 Festmontage  
 Sichtweite: 2sm

Typ: AS 426 - blau

Lanterns Type 426  
Laternen Typ 426



**Tri-Color Signal Light**

socket BAY15d  
without bulb  
fixed assembly  
visibility: 2nm

4264400

type: AD 426 - red/green/white

**Seglerlaterne**

Fassung BAY15d  
ohne Glühlampe  
Festmontage  
Sichtweite: 2sm

Typ: AD 426 - rot / grün / weiß



**Signal Light**

socket BAY15d  
without bulb  
fixed assembly  
visibility: 2nm

4265400

type: AS 426 - yellow

**Signallaterne**

Fassung BAY15d  
ohne Glühlampe  
Festmontage  
Sichtweite: 2sm

Typ: AS 426 - gelb



**Combi - Lantern**

socket BAY15d  
without bulbs  
fixed assembly  
visibility: 2nm

4281400

type: ADA 426 - white / red-green-white

**Kombi - Laterne**

Fassungen BAY15d  
ohne Glühlampen  
Festmontage  
Sichtweite: 2sm

Typ: ADA 426 - weiß / rot-grün-weiß



**Combi - Lantern**

socket BAY15d  
without bulbs  
fixed assembly  
visibility: 2nm

4282100

type: ADA 426 - white / yellow

**Kombi - Laterne**

Fassungen BAY15d  
ohne Glühlampen  
Festmontage  
Sichtweite: 2sm

Typ: BTS 426 - weiß / gelb

Lanterns Type 426  
*Laternen Typ 426*



**Spare Lens**

4269100

for anchor light A 426 - white

**Ersatz - Linse**

für Ankerlaterne A 426 - weiß



**Spare Lens**

4269300

for tricolor light AD 426 - red/white/  
green

**Ersatz - Linse**

für Seglerlaterne AD 426 - rot/weiß/  
grün



**Protection Cap**

4292000

for winter camp - type 426

**Schutzkappe**

für Winterlager Laterne Typ 426



**Tube Connector**

for tube diameter 25 mm

4297800

for lantern type 426

**Rohraufsatz**

für Rohrdurchmesser 25mm

für Laterne Typ 426

Lanterns Type 427  
*Endprodukte Type 427*



**Anchor Light**

socket BAY15d  
without bulb  
hoistable  
visibility: 2nm

4271400

type: A 427 - white

**Ankerlaterne**

Fassung BAY15d  
ohne Glühlampe  
aufheissbar  
Sichtweite: 2sm

Typ: A 427 - weiß



**Signal Light**

socket BAY15d  
without bulb  
hoistable  
visibility: 2nm

4272400

type: AS 427 - red

**Signallaterne**

Fassung BAY15d  
ohne Glühlampe  
aufheissbar  
Sichtweite: 2sm

Typ: AS 427 - rot





Lanterns Type 427  
Endprodukte Type 427

**Signal Light**  
socket BAY15d  
without bulb  
hoistable  
visibility: 2nm

4273400

type: AS 427 - green

**Signallaterne**  
Fassung BAY15d  
ohne Glühlampe  
aufheissbar  
Sichtweite: 2sm

Typ: AS 427 - grün



**Signal Light**  
socket BAY15d  
without bulb  
hoistable  
visibility: 2nm

4274600

type: AS 427 - blue

**Signallaterne**  
Fassung BAY15d  
ohne Glühlampe  
aufheissbar  
Sichtweite: 2sm

Typ: AS 427 - blau



**Signal Light**  
socket BAY15d  
without bulb  
hoistable  
visibility: 2nm

4274700

type: AS 427 - yellow

**Signallaterne**  
Fassung BAY15d  
ohne Glühlampe  
aufheissbar  
Sichtweite: 2sm

Typ: AS 427 - gelb

Lanterns Type 431  
Laternen Typ 431



**Tri-Colour Signal Light**  
socket BAY15d  
without bulb  
fixed assembly  
visibility: 2nm

4060301

type: AD 431 - red/green/white

**Dreifarbige Seglerlaterne**  
Fassung BAY15d  
ohne Glühlampe  
Festmontage  
Sichtweite: 2sm

Typ: AD 431 - rot/grün/weiß

Lanterns Type 431  
*Laternen Typ 431*

**Anchor Light**

socket BAY15d  
without bulb  
fixed assembly  
visibility: 2nm

4116100

type: A 431 - white



**Ankerlaterne**

Fassung BAY15d  
ohne Glühlampe  
Festmontage  
Sichtweite: 2sm

Typ: A 431 - weiß

**Signal Light**

socket BAY15d  
without bulb  
fixed assembly  
visibility: 2nm

4126100

type: AS 431 - red



**Signallaterne**

Fassung BAY15d  
ohne Glühlampe  
Festmontage  
Sichtweite: 2sm

Typ: AS 431 - rot

**Signal Light**

socket BAY15d  
without bulb  
fixed assembly  
visibility: 2nm

4136100

type: AS 431 - green



**Signallaterne**

Fassung BAY15d  
ohne Glühlampe  
Festmontage  
Sichtweite: 2sm

Typ: AS 431 - grün

**Signal Light**

socket BAY15d  
without bulb  
fixed assembly  
visibility: 2nm

4139200

type: AS 431 - yellow



**Signallaterne**

Fassung BAY15d  
ohne Glühlampe  
Festmontage  
Sichtweite: 2sm

Typ: AS 431 - gelb



Lanterns Type 431  
Laternen Typ 431

**Spare Lens - tricolor**  
for lantern AD 431

4098100

with bottom

**Linse 3-farbig**  
für Laterne AD 431

mit Boden



**Spare Lens - white**  
for lantern A 400/431

4191100

with bottom

**Ersatzlinse - weiß**  
für Laterne A 400/431

mit Boden



**Spare Lens - red**  
for lantern AS 400/431

4191200

with bottom

**Ersatzlinse - rot**  
für Laterne AS 400 / AS 431

mit Boden



**Spare Lens - green**  
for lantern AS 400/431

4191300

with bottom

**Ersatzlinse - grün**  
für Laterne AS 400/431

mit Boden



**Spare Lens - yellow**  
for lantern AS 400/431

4191400

with bottom

**Ersatzlinse - gelb**  
für Laterne AS 400/431

mit Boden



**Light Insert**  
complete

4195500

for lantern type A / AS 431

**Lichteinsatz**  
komplett

für Laterne Typ A / AS 431

Lanterns Type 400  
Laternen Typ 400



**Anchor Light**  
socket BAY15d  
without bulb  
hoistable  
visibility: 2nm

4115400

type: A 400 - white

**Ankerlaterne**  
Fassung BAY15d  
ohne Leuchtmittel  
aufheissbar  
Sichtweite: 2sm

Typ: A 400 - weiß

Lanterns Type 400  
*Laternen Typ 400*



**Signal Light**  
socket BAY15d  
without bulb  
hoistable  
visibility: 2nm

4125400

type: AS 400 - red

**Signallaterne**  
Fassung BAY15d  
ohne Leuchtmittel  
aufheissbar  
Sichtweite: 2sm

Typ: AS 400 - rot



**Signal Light**  
socket BAY15d  
without bulb  
hoistable  
visibility: 2nm

4135400

type: AS 400 - green

**Signallaterne**  
Fassung BAY15d  
ohne Leuchtmittel  
aufheissbar  
Sichtweite: 2sm

Typ: AS 400 - grün



**Light Insert**  
complete

4195000

for lantern type A/AS 400 - hoistable für Laterne Typ 400 - heissbar

**Lichteinsatz**  
komplett

Bulbs for Yacht Lights  
*Glühlampen Yachtlaternen*



**Bulb**  
socket BAY15d  
DANLAMP

4090300

12 Volt - 10 Watt

4090400

12 Volt - 25 Watt

4090500

24 Volt - 10 Watt

4090600

24 Volt - 25 Watt

**Glühlampe**  
Fassung BAY15d  
DANLAMP

12 Volt - 10 Watt

12 Volt - 25 Watt

24 Volt - 10 Watt

24 Volt - 25 Watt

Navigation Lights  
*Navigationslaternen*

Navy Lamps  
*Marinelaternen*

# Navy Lamps *Marinelaternen*

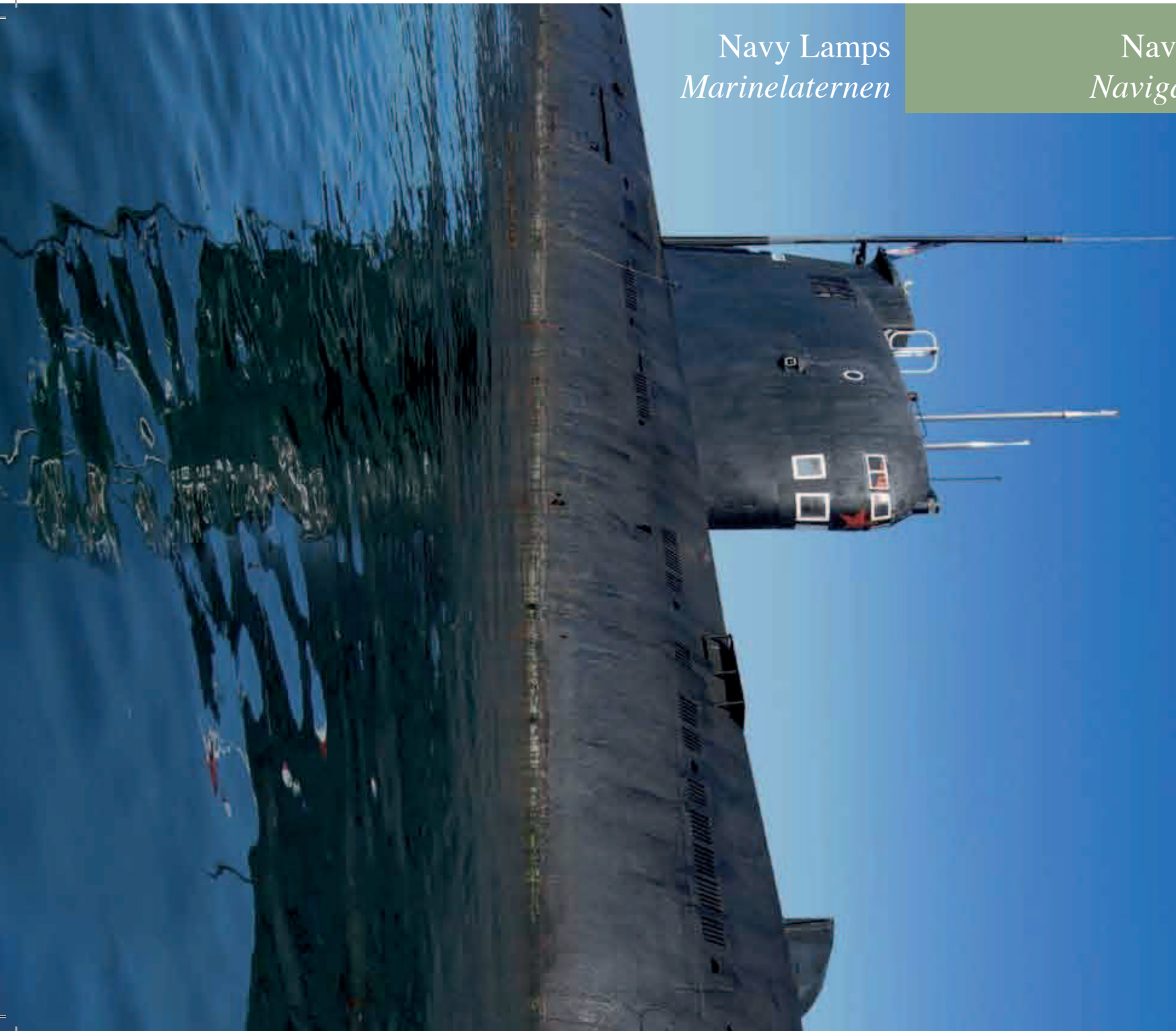



Navy Lanterns  
*Marinelaternen*



**Wake Light**  
 socket E27 - grey coated

2522000

white

2522100

blue



**Delimitation Light**  
 socket E27 - grey coated

2532000

blue



**Steering Light**  
 socket E27 - grey coated

2542000

blue

2542010

white



**Spacer Light**  
 socket E27 - grey coated

2551100

blue - - 110 dregrees



**Socket**  
 brass

2419120

B15- 2 feet flange



**Socket E27**  
 brass

2591000

with thread M10 x 1

**Kielwasserlaterne**  
 Fassung E27 - grau lackiert

weiß

blau

**Begrenzungslaterne**  
 Fassung E27 - grau lackiert

blau

**Steuerlicht**  
 Fassung E27 - grau lackiert

blau

weiß

**Abstandslaterne**  
 Fassung E27 - grau lackiert

blau - 110 Grad

**Fassung**  
 Messing

Zweibock - B15

**Fassung E27**  
 Messing

mit Gewinde M10 x 1



Navy Lanterns  
*Marinelaternen*

**Socket B22**  
brass

2591300

with thread M10 x 1

**Fassung B22**  
Messing

mit Gewinde M10 x 1



**Socket B15 d**  
brass

2697100

two-support version

**Fassung B15d**  
Messing

Zweibock

Submarine Lights  
*Laternen U-Boot*



**Submarine - Double Side Light**

socket P28s  
cable entry for 2 - pole cable  
pressure resistant up to 63 bar

6510300

type: DLS 650/72 - green - 115V

**U-Boot - Doppel - Seitenlaterne**

Fassung P28s  
mit Kabeleinführung für 2 - poliges  
Kabel  
Druckfest bis 63 bar

Typ: DLS 650/72 - grün - 115V



**Submarine - Double Side Light**

socket P28s  
cable entry for 2 - pole cable  
pressure resistant up to 63 bar

6520300

type: DLB 650/72 - red - 115V

**U-Boot - Doppel - Seitenlaterne**

Fassung P28s  
mit Kabeleinführung für 2 - poliges  
Kabel  
Druckfest bis 63 bar

Typ: DLB 650/72 - rot - 115V

Submarine Lights  
*Laternen U-Boot*



**Submarine - Stern Light**  
socket P28s  
cable entry for 2-pol cable  
pressure resistant up to 63 bar

6540300

type: H 650/72 - white - 115V

**U-Boot - Hecklaterne**  
Fassung P28s  
mit Kabeleinführung für 2-poliges  
Kabel  
Druckfest bis 63 bar

Typ: H 650/72 - weiß - 115V



**Identification Light**  
socket E27  
with GISMA Plug Socket  
pressure resistant up to 63 bar

6578020

type: EL 650/72 - white - 24V

**Erkennungsleuchte**  
Fassung E27  
mit GISMA Steckdose  
Druckfest bis 63 bar

Typ: EL 650/72 - weiß - 24V



**Submarine - Masthead-Anchor Light**  
socket P28s  
with GISMA plug socket  
pressure resistant up to 63 bar

6601100

type: TA 650/72 - white - 115V

6601200

type: TA 650/72 - white - 230V

**U-Boot - Topp - Ankerlaterne**  
Fassung P28s  
mit GISMA Steckdose  
Druckfest bis mindestens 63 bar

Typ: TA 650/72 - weiß - 115V

Typ: TA 650/72 - weiß - 230V



**Submarine - Stern Light**  
socket P28s  
with GISMA Plug Socket  
tiltable execution

6601500

type: H 650/72 - white - 230V

**U-Boot - Hecklaterne**  
Fassung P28s  
mit GISMA Steckdose  
Ausführung schwenkbar

Typ: H 650/72 - weiß - 230V

Submarine Lighting  
*Beleuchtung U-Boot*



**Tower Light**  
socket B22  
with GISMA plug socket  
protective bowl  
pressure resistant up to 63 bar

**6603120**

2-Introduction connecting - red - 24V

**6603140**

2-Introduction connecting - red - 115V

**Turmleuchte**  
Fassung B22  
mit GISMA Steckdose  
Schutzkorb  
Druckfest bis mindestens 63 bar

2 Einführungsstutzen - rot - 24V

2 Einführungsstutzen - rot - 115V



**Tower Light**  
socket B22  
with GISMA Plug Socket  
protective bowl

**6603320**

1-Introduction connecting - red - 24V

**Turmleuchte**  
Fassung B22  
mit GISMA Steckdose  
Schutzkorb

1 Einführungsstutzen - rot - 24V

External LED Lights  
*LED-Leuchten Außenbereich*



**LED Spotlight**  
 4,5 watt - 1200cd - 10 degrees  
 IP 67 - hardanodizes  
 Container Walkway Light

**2720100**

type: CWL80 - 230V - cold white

**2720103**

type: CWL80 - 115/120V - cold white

**2720104**

type: CWL80 - 230V - warm white

**2720105**

type: CWL80 - 24V - cold white

**LED Strahler**  
 4,5 Watt - 1200cd - 10 Grad  
 IP 67 - harteloxiert  
 Container Walkway Light

Typ: CWL80 - 230V - kaltweiß

Typ: CWL80 - 115/120V - kaltweiß

TYP: CWL80 - 230V - warmweiß

Typ: CWL80 - 24V - kaltweiß



**LED - Stripe Light**  
 cable length: 1,5m  
 structure height: 15mm  
 power supply: 11-28V AC/DC

**5091048**

type: IL 400mm - structure - 1,4W

Typ: IL 400mm - Aufbau - 1,4W

**5091049**

type: IL 600mm - structure - 2,1W

Typ: IL 600mm - Aufbau - 2,1W

**5091050**

type: IL 800mm - structure - 2,8W

Typ: IL 800mm - Aufbau - 2,8W

**5091051**

type: IL 1000mm - structure - 3,5W

Typ: IL 1000mm - Aufbau - 3,5W

**5091052**

type: IL 1200mm - Structure - 4,2W

Typ: IL 1200mm - Aufbau - 4,2W



**LED - Stripe Light**  
 cablelength: 1,5m  
 power supply: 11-28V AC/DC

**5091054**

type: IL 600mm - installation - 2,1W

Typ: IL 600mm - Einbau

**5091055**

type: IL 800mm - installation - 2,8W

Typ: IL 800mm - Einbau - 2,8W

**5091056**

type: IL 1000mm - installation - 3,5W

Typ: IL 1000mm - Einbau - 3,5W

**5091057**

type: IL 1200mm - installation - 4,2W

Typ: IL 1200mm - Einbau - 4,2W

**5091075**

type: IL 200mm - installation

Typ: IL 200mm - Einbau



External LED Lights  
LED-Leuchten Außenbereich



**LED - Deck Floodlight**  
with 1m cable  
d = 54mm  
structure height: 22mm  
power supply: 11-28V AC/DC  
power consumption: 3W  
luminous intensity: 900cd  
radiation angle: 16 degrees

5091065

type: BWL 54 - coldwhite

**LED - Salingleuchte**  
mit 1m Kabel  
D = 54mm  
Aufbauhöhe: 22mm  
Spannung: 11-28V AC/DC  
Leistung: 3W  
Lichtstärke: 900cd  
Ausstrahlungswinkel: 16 Grad

Typ: BWL 54 - kaltweiß



**LED - Floodlight**  
with 1m cable  
d = 83mm  
depth: 39,5mm  
installation drilling: 62mm  
power supply: 11-28V AC/DC  
power consumption: 4,5W  
luminous intensity: 870cd  
radiation angle: 23 degrees

5091066

type: BWL 83 - silver - cold white

5091072

type: BWL 83 - silber - warm white

**LED - Salingleuchte**  
mit 1m Kabel  
D = 78mm  
Einbautiefe: 39,5mm  
Einbaubohrung: 62mm  
Spannung: 11-28V AC/DC  
Leistung: 4,5W  
Lichtstärke: 870cd  
Ausstrahlungswinkel: 23 Grad

Typ: BWL 83 - silber - kaltweiß

Typ: BWL 83 - silber - warmweiß



**LED - Floodlight**  
with 1m cable  
d = 83mm  
depth: 39,5mm  
installation drilling: 62mm  
power supply: 11-28V AC/DC  
power consumption: 4,5W  
luminous intensity: 870cd  
radiation angle: 23 degrees

5091067

type: BWL 83 - black - cold white

5091068

type: BWL 83 - black - warm white

**LED - Salingleuchte**  
mit 1m Kabel  
D = 78mm  
Einbautiefe: 39,5mm  
Einbaubohrung: 62mm  
Spannung: 11-28V AC/DC  
Leistung: 4,5W  
Lichtstärke: 870cd  
Ausstrahlungswinkel: 25 Grad

Typ: BWL 83 - schwarz - kaltweiß

Typ: BWL 83 - schwarz - warmweiß



**LED - Boomlight**  
with 1m cable  
d = 50mm  
depth: 38,5mm  
installation drilling: 46mm  
power supply: 11-28V AC/DC  
power consumption: 4W  
radiation angle: 35 degrees

5091069

type: BWL 50 - silver - cold white

**LED - Salingleuchte**  
mit 1m Kabel  
D = 50mm  
Einbautiefe: 38,5mm  
Einbaubohrung: 46mm  
Spannung: 11-28V AC/DC  
Leistung: 4W  
Ausstrahlungswinkel: 35 Grad

Typ: BWL 50 - silber - kaltweiß

External LED Lights  
LED-Leuchten Außenbereich



**LED - Spotlight**  
with 1m cable  
power supply: 12V – 24V DC  
power consumption: 8 Watts  
radiation angle: 44°x15°  
depth: 58mm  
installation drilling: 78mm  
power input: 650mA - 330mA  
protection: IP 67  
Lux/m 1160

5091070

type: HEL100

**LED - Strahler**  
mit 1m Kabel  
Leistung: 8W  
Austrahlungswinkel: 44°x15°  
Einbautiefe: 58mm  
Einbaubohrung: 78mm  
Spannung: 12V – 24V DC  
Stromaufnahme: 650mA – 330mA  
Schutzart: IP 67  
Lux/m 1160

Typ: HEL100



**LED - Boomlight**  
with 1m cable  
D = 66mm  
Depth: 38,5mm  
Installation drilling: 46mm  
power supply: 11-28V AC/DC  
power consumption: 4 Watts  
Radiation angle: 35 degrees

5091090

type: BWL 66 - silver - cold white

**LED - Salingleuchte**  
mit 1m Kabel  
D = 66mm  
Einbautiefe: 38,5mm  
Einbaubohrung: 46mm  
Spannung: 11-28V AC/DC  
Leistung: 4 Watt  
Ausstrahlungswinkel: 35 Grad

Typ: BWL 66 - silber - kaltweiß

5091091

type: BWL 66 - silver - warm white

Typ: BWL 66 - silver - warmweiß



**LED - Boomlight**  
with 1m cable  
D = 66mm  
Depth: 38,5mm  
Installation drilling: 46mm  
power supply: 11-28V AC/DC  
power consumption: 4 Watts  
Radiation angle: 35 degrees

5091092

type: BWL 66 - black - cold white

**LED - Salingleuchte**  
mit 1m Kabel  
D = 66mm  
Einbautiefe: 38,5mm  
Einbaubohrung: 46mm  
Spannung: 11-28V AC/DC  
Leistung: 4 Watt  
Ausstrahlungswinkel: 35 Grad

Typ: BWL 66 - schwarz - kaltweiß

5091093

type: BWL 66 - black - warm white

Typ: BWL 66 - schwarz - warmweiß



**LED - Floodlight**  
with 1m marine cable  
glasscover  
neutral white  
coated RAL 9007  
power consumption: 12 Watts  
radiation angle: 90°  
power input: 420mA  
protection: IP 67  
alloy bracket

5093000

type: PB FL12 - 230V - neutral white

**LED - Flutlichtstrahler**  
mit Marinekabel - 1m  
Glasscheibe - 3mm  
neutralweiß  
pulverbeschichtet RAL 9007  
Leistung: 12W  
Austrahlungswinkel: 90°  
Stromaufnahme: 420mA  
Schutzart: IP 67  
Alubügel

Typ: PB FL12 - 230V - neutral weiß

5093002

type: PB FL12 - 24V - neutral white

Typ: PB FL12 - 24V - neutral weiß



External LED Lights  
*LED-Leuchten Außenbereich*

**LED - Floodlight**  
with 1m marinecable  
power consumption: 20W  
radiation angle: 25°  
power input: 800mA  
protection: IP 67  
alloy bracket

**5093003**

type: PB FL20 - 24V - neutral white    *Typ: PB FL20 - 24V - neutral weiß*

**LED - Flutlichtstrahler**  
*mit Marinekabel - 1m*  
*Leistung: 20W*  
*Austrahlungswinkel: 25°*  
*Stromaufnahme: 800mA*  
*Schutzart: IP 67*  
*Alubügel*

**LED - Floodlight**  
320x270x170mm  
radiation angle: 60/120°  
cold white  
protection: IP 65

**5093010**

type: PB 60 - 230V - 60W

**LED - Flutlichtstrahler**  
320x270x170mm  
*Austrahlungswinkel: 60/120°*  
*Kaltweiß*  
*Schutzart: IP 65*

*Typ: PB 60 - 230V - 60W*

**LED - Warning Flashlight**  
dimensions: Ø 10,5cm  
height: 3,5cm  
9 different light programs

**5093111**

according to 2002/95/EG

**LED - Warnblitzer**  
*Maße Ø 10,5cm*  
*Höhe 3,5cm*  
*9 verschiedene Lichtprogramme*

*Geprüft nach Richtlinie 2002/95/EG*

A photograph of a ship's mast against a clear blue sky. The mast is a tall, light-colored pole with several horizontal cross-arms. On the right side, several flags are flying: a green flag with 'RAI' on it, a red and white flag, and a white flag with blue and black patterns. On the left side, a large red cylindrical buoy hangs from a cross-arm. At the top of the mast, there is a small black dome-shaped object. The background is a bright blue sky with a few wispy clouds. A solid yellow vertical bar is on the right edge of the image.

Signals  
*Signale*



Gongs  
Gongs

**Foggong**

brass  
Approval No.: DHI/02/05G/77  
for vessels > 100m in length.  
In conformity with the COLREG  
1972

3411100

42 cm - with mallet

**Nebelgong**

Messing  
Zulassungsnummer: DHI/02/05G/77  
für Fahrzeuge > 100m Länge  
gemäß COLREG 1972

42 cm - mit Schlegel



**Foggong**

brass  
Approval No.: DHI/02/05G/77  
for vessels > 100m in length.  
In conformity with the COLREG  
1972

3411200

50 cm - with mallet

**Nebelgong**

Messing  
Zulassungsnummer: DHI/02/05G/77  
für Fahrzeuge > 100m Länge  
gemäß COLREG 1972

50 cm - mit Schlegel

Bells  
Glocken



**Bell**

1110900

12cm - brass polished

**Glocke**

12 cm - Messing poliert

1111000

14cm - brass polished

14 cm - Messing poliert



**Bell**

Approval No.:  
BSH/4615/6020093/05  
Approved for vessels  
> 12 m < 20 m in length.  
In conformity with the COLREG  
1972

1111100

20cm - brass polished

**Glocke**

Zulassungsnummer:  
BSH/4615/6020093/05  
Zugelassen für Fahrzeuge  
> 12 m < 20 m Länge  
gemäß COLREG 1972

20cm - Messing poliert

1111300

30cm - brass polished - 2. choice

30cm - Messing poliert - 2. Wahl



**Bell Lanyard**

1112000

13cm - with shackle

**Glockenbändsel**

13cm - mit Schäkel



Bells  
Glocken



**Bell Lanyard**

1112100

17cm with shackle

**Glockenbändsel**

17cm - mit Schäkel



**Bell Lanyard**

1112200

21cm with shackle

**Glockenbändsel**

21cm mit Schäkel



**Bell Holder**  
brass

1112400

for bells D = 30cm

1112500

for bells D = 20cm

1112600

for bells D = 12/14cm

**Glockenhalter**  
Messing

für Glockendurchmesser 30cm

für Glockendurchmesser 20cm

für Glockendurchmesser 12/14cm

Horns  
Hörner



**Gascartridge**

1101300

300 ml - for Gashorn

**Gaskartusche**

300 ml - für Gashorn



**Gashorn**

1101400

with gas cartridge - 300ml

**Gashorn**

mit Gaskartusche - 300 ml



Horns  
Hörner

**Pump Fog Horn**  
steel coated

1113000

53cm - SBG approval

**Pumpnebelhorn**  
Stahl gepulvert

53cm - SBG Zulassung



**Pump Fog Horn**

1113100

55cm - brass polished

**Pumpnebelhorn**

55cm - Messing poliert



**Foghorn**

3421000

40cm - brass

**Mundnebelhorn**

40cm - Messing



**Voice - Foghorn**

3422300

40cm - brass

**Sprachrohr -  
Mundnebelhorn**

40cm - Messing

Megaphones  
Megaphone



**Megaphon**

1114000

43cm - brass

**Megaphon**

43cm - Messing



**Megaphon**  
with batteries

1114500

battery operated

**Megaphon**  
mit Batterien

Batteriebetrieb

Merchant Flag  
*Handelsflagge*

Merchant Flag

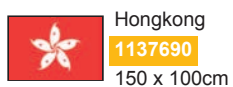
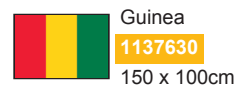
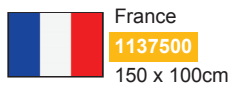
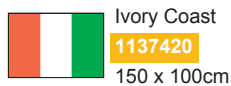
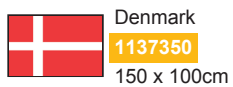
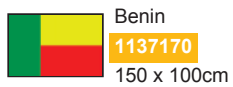
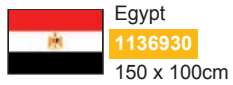

Merchant Flag  
Handelsflagge

Merchant Flag

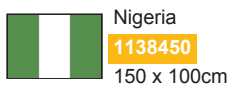
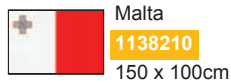
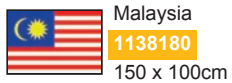
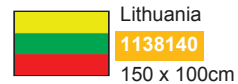
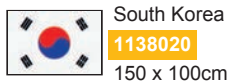
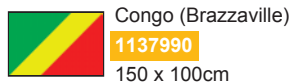
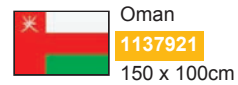
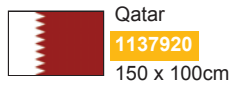
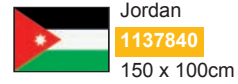
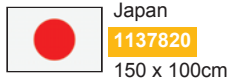

Merchant Flag  
*Handelsflagge*

Merchant Flag

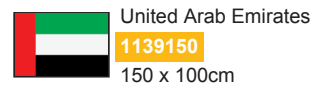
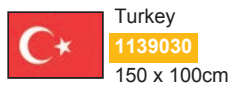
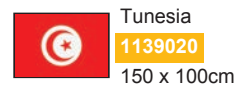
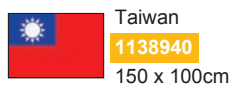
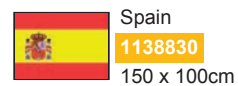
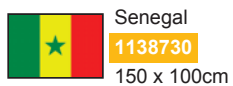
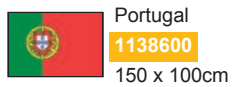
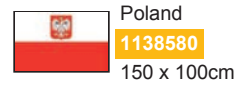
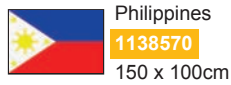



Signal Flag  
Signalflagge

Signal Flag

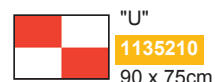
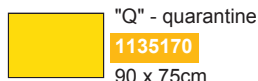
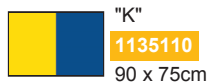
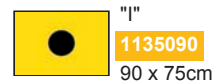
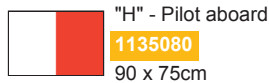

Signal Pennant  
*Signalwimpel*

Signal Pennant

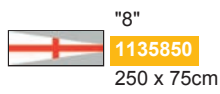
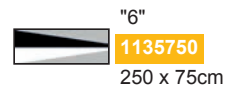
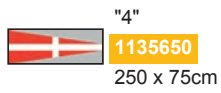



Substitute Pennant  
*Hilfsstander*

**1. Substitute Pennant**

**1136050**

90 x 75cm

**1. Hilfsstander**

90 x 75cm

**2. Substitute Pennant**

**1136100**

90 x 75cm

**2. Hilfsstander**

90 x 75cm

**3. Substitute Pennant**

**1136150**

90 x 75cm

**3. Hilfsstander**

90 x 75cm

Day Signals  
*Tagessignale*



**Signal Ball**

canvas - black - hinged

**1121000**

diameter - 60cm

**Signalball**

Segeltuch - schwarz - klappbar

Durchmesser - 60cm



**Signal Cylinder**

PVC - black - hinged

**1121200**

60 x 120cm

**1121201**

40 x 80cm

**Signalzylinder**

PVC - schwarz - klappbar

60 x 120cm

40 x 80cm



**Signal Cone**

PVC - black - hinged

**1121300**

60 x 60cm

**Signalkegel**

PVC - schwarz - klappbar

60 x 60cm

Day Signals  
Tagessignale



**Signal Rhombus**  
PVC - black - hinged

1121400

60 x 120cm

1121401

40 x 80cm

**Signalrhombus**

PVC - schwarz - klappbar

60 x 120cm

40 x 80cm



**Signal Ball**  
PVC - black - hinged

1121500

diameter - 60cm

**Signalball**

PVC - schwarz - klappbar

Durchmesser - 60cm



**Signal Ball**  
net - black - hinged

1121510

diameter - 60cm

**Signalball**

Netz - schwarz - klappbar

Durchmesser - 60cm



**Signal Cylinder**  
net - black - hinged

1121520

60 x 120cm

**Signalzylinder**

Netz - schwarz - klappbar

60 x 120cm



**Signal Double Cone**  
net - black - hinged

1121530

60 x 120cm

**Signal - Doppelkegel**

Netz - schwarz - klappbar

60 x 120cm



**Signal Rhombus**  
net - black - hinged

1121540

60 x 120cm

**Signalrhombus**

Netz - schwarz - klappbar

60 x 120cm



Day Signals  
Tagessignale

**Signal Cone**  
net - black - hinged

1121550

60 x 60cm

**Signalkegel**

Netz - schwarz - klappbar

60 x 60cm



**Signal Cylinder**  
canvas - black - hinged

1122000

60 x 120cm

**Signalzylinder**

Segeltuch - schwarz - klappbar

60 x 120cm



**Signal Cylinder**  
PVC - red - hinged

1122100

60 x 100cm

**Signalzylinder**

PVC - rot - klappbar

60 x 100cm



**Signal Double Cone**  
canvas - black - hinged

1122980

60 x 120cm

**Signal - Doppelkegel**

Segeltuch - schwarz - klappbar

60 x 120cm



**Signal Cone**  
canvas - black - hinged

1123000

60 x 60cm

**Signalkegel**

Segeltuch - schwarz - klappbar

60 x 60cm



**Signal Rhombus**  
canvas - black - hinged

1124100

60 x 120cm

**Signalrhombus**

Segeltuch - schwarz - klappbar

60 x 120cm



Day Signals  
Tagessignale

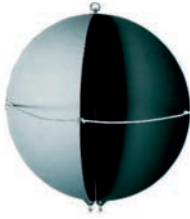

**Signal Ball**  
aluminium - powder coated -  
pluggable

**3811200**

diameter - 60cm - black

**Signalball**  
Aluminium - Pulverbeschichtet -  
steckbar

Durchmesser - 60cm - schwarz



**Signal Rhombus**  
aluminium - powder coated -  
pluggable

**3811300**

60 x 120cm - black

**Signalrhombus**  
Aluminium - Pulverbeschichtet -  
steckbar

60 x 120 cm - schwarz

Accessories  
Zubehör Optische Signale



**Swirl for Flag Lines**

**1135000**

2 Parts - brass - 50mm

**Flaggleinenwirbel**

2 Teile - Messing - 50mm

Pyrotechnics - Commercial  
Pyrotechnik - Beruf



**Distress - Signals Set**

**1920201**  
for bridge

**Notsignale Satz**

für Brücke



**Distress - Signals Set**  
in accordance to SOLAS

**1920202**  
for lifeboat

**Notsignale Satz**  
gemäß SOLAS

für Rettungsboot



**IKAROS - Parachute Rocket**

light intensity: 30.000 cd  
flare ejection height: 350m  
burning time: >40 sec.  
dimensions: 277x47mm

**1921001**  
Hansson - 340100 - red

**IKAROS - Fallschirmrakete**

Lichtstärke: 30.000 cd  
Steighöhe: 350m  
Brenndauer: >40 sec.  
Abmessung: 277x47mm

Hansson - 340100 - rot



**IKAROS - 2-Star Rocket**

**1921101**  
Hansson - 340700 - red

**IKAROS - 2-Sternrakete**

Hansson - 340700 - rot



**IKAROS - 1-Star Rocket**

**1921102**  
Hansson - 340500 - red

**IKAROS - 1-Sternrakete**

Hansson - 340500 - rot

Pyrotechnics - Commercial  
Pyrotechnik - Beruf



**IKAROS - Handflare**

light intensity: 15.000 cd  
burning time: >60 sec.  
dimensions: 243x30mm

**1922001**

Hansson - 341500 - red

**IKAROS - Handfackel**

Lichtstärke: 15.000 cd  
Brenndauer: >60 sec.  
Abmessung: 243x30mm

Hansson - 341500 - rot



**IKAROS - Parachute Rocket**

light intensity: 100.000 cd  
flare ejection height: 350m  
burning time: >30 sec.  
dimensions: 277x47mm

**1923301**

Hansson - 340200 - white

**IKAROS - Fallschirmrakete**

Lichtstärke: 100.000 cd  
Steighöhe: 350m  
Brenndauer: >30 sec.  
Abmessung: 277x47mm

Hansson - 340200 - weiß



**IKAROS - Linethrowing Device**

line: 300m - d=4mm  
performance: 300m  
dimensions: 340x230mm  
Hansson - 346100

**1925111**

Single Shot System - complete

**IKAROS - Leinenschießgerät**

Leine: 300m - D=4mm  
Wurfweite: 300m  
Abmessung: 340x230mm  
Hansson - 346100

Einzelschuss komplett



**Line Throwing Rocket**

Hansson - 346200

**1925501**

IKAROS - Line Throwing Device

**Treibsatz**

Hansson - 346200

IKAROS -Leinenschießgerät

Pyrotechnics - Commercial  
Pyrotechnik - Beruf



**IKAROS - Light - Smoke - Signal (MOB)**  
light intensity: 2cd  
light burning time: > 2 hours  
smoke duration timer: > 15 minutes  
dimensions: 200x500mm  
Hansson - 345105  
release height: up to 60m

**1931011**

inclusive bracket

**IKAROS - Licht - Rauch - Signal (MOB)**  
Lichtstärke: 2cd  
Lichtbrenndauer: > 2 Stunden  
Rauchbrenndauer: > 15 Minuten  
Abmessung: 200x500mm  
Hansson - 345105  
Abwurfhöhe: bis 60m

komplett mit Halter



**IKAROS - Smoke Signal**  
burning time: >3 minutes

**1934001**

Hansson - 342130 - orange

**IKAROS - Rauchsignal**  
Brenndauer: >3 Minuten

Hansson - 342130 - orange

Pyrotechnics - Pleasure  
Pyrotechnik - Sport



**Distress Signal - Set**  
Comet - 9194700

**1935111**

with 3 cartridges red

**Signalgeber - Set**  
Comet - 9194700

mit 3 roten Signalpatronen



**Distress Signal - Set**  
Comet - 9194600

**1935112**

with 9 cartridges red

**Signalgeber - Set**  
Comet - 9194600

mit 9 roten Signalpatronen

Pyrotechnics - Pleasure  
 Pyrotechnik - Sport



**IKAROS - Hand Smoke - orange**

burning time: >60 sec.  
 dimensions: 243x30mm

1991101

Hansson - 341700

**IKAROS - Rauchfackel - orange**

Brenndauer: >60 sec.  
 Abmessung: 243x30mm

Hansson - 341700



**IKAROS - Combination Signal**

light intensity: 10.000cd  
 burning time: >15 sec.  
 smoke time: >15 sec.  
 dimensions: 135x42mm  
 Hansson - 343200

1991102

Handflare - red / Hand Smoke - orange

**IKAROS - Kombisignal**

Lichtstärke: 10.000cd  
 Brenndauer: >15 sec.  
 Rauchdauer: >15 sec.  
 Abmessung: 135x42mm  
 Hansson - 343200

Handfackel - rot / Rauchfackel - orange



**IKAROS - Handflare**

light intensity: 10.000 cd  
 burning time: >60 sec.  
 dimensions: 243x30mm

1991301

Hansson - 341600 - white

**IKAROS - Handfackel**

Lichtstärke: 10.000 cd  
 Brenndauer: >60 sec.  
 Abmessung: 243x30mm

Hansson - 341600 - weiß

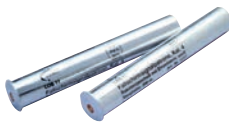

**Parachute Cartridge**

Comet - 9122600

1992000

caliber 4 - red

**Fallschirmpatrone**

Comet - 9122600

Kaliber 4 - rot



**Fulminating Cartridge**

Comet - 9122500

1992100

caliber 4

**Blitzknallpatrone**

Comet - 9122500

Kaliber 4



Pyrotechnics - Pleasure  
Pyrotechnik - Sport



**Signal Cartridge**  
Comet - 9182000

**1992200**

caliber 4 - red

**Signalpatrone**  
Comet - 9182000

Kaliber 4 - rot



**Signal Cartridge**  
Comet - 9182100

**1992300**

caliber 4 - white

**Signalpatrone**  
Comet - 9182100

Kaliber 4 - weiß



**Signal Cartridge**  
Comet - 9182200

**1992400**

caliber 4 - green

**Signalpatrone**  
Comet - 9182200

Kaliber 4 - grün



**Distress Set**  
category 5

**1993451**

Inland Waterways

**Notsignalsatz**  
Kategorie 5

Binnen



**Distress Set**  
category 4

**1993501**

Coast

**Notsignalsatz**  
Kategorie 4

Küste



**Distress Set**  
category 2/3

**1993601**

Sea

**Notsignalsatz**  
Kategorie 2/3

See



**Distress Set**  
category 0/1

**1993701**

Open Sea

**Notsignalsatz**  
Kategorie 0/1

Hochsee

Accessories  
Zubehörteile



**Connecting Rope**

**1831420**

for MOB - 4 m

**Verbindungsleine für**

MOB - 4 m

Accessories  
Zubehörteile



**Signal Pistol**  
from authority existence  
Comet - 9121800

**1992610**

type: DIANA - Cal. 4

**Signalpistole**  
aus Behördenbeständen  
Comet - 9121800

Typ: DIANA - Kaliber 4



**Container**  
watertight  
for distress signals

**1993000**

white with blue cover

**Container**  
wasserdicht  
für Seenotsignale

weiß mit blauem Deckel



**Container**  
watertight  
volume: 15.4 litres  
for distress signals

**1993001**

white with red cover

**Container**  
wasserdicht  
Volumen: 15.4 Liter  
für Seenotsignale

weiß mit rotem Deckel



**Can**  
inland waterways / coast  
watertight  
Hanssons - 355920

**1993201**

for distress set

**Dose**  
Wasserdicht  
Hanssons - 355920

für Notsignalsatz Binnen/Küste



**Sticker - "Distress Signals"**  
self adhesive

**1993202**

140 x 140mm

**Aufkleber - "Seenotsignale"**  
selbstklebend

125 x 125mm



**Can**  
watertight  
Hanssons - 355930

**1993301**

for distress set - sea

**Dose**  
Wasserdicht  
Hanssons - 355930

für Notsignalsatz - See



**Cleaning Set**  
Comet - 9129500

**1993400**

for signal pistol Cal. 4

**Reinigungsset**  
Comet - 9129500

für Signalpistole Kaliber 4



Life Saving Appliance

*Rettungsmittel*







Foam Lifejackets  
Feststoffwesten

**Lifejacket - Foam**  
Light - Whistle - Reflective Tape  
according ISO 124202-2

1836402

type: Plastimo - Storm type 3 - 100N

**Rettungsweste - Feststoff**  
Notlicht - Pfeife - Reflexfolie  
gemäß ISO 124202-2

Typ: Plastimo - Storm Type 3 - 100N



**Lifejacket - Foam**  
Light - Whistle - Reflective Tape

1836410

type: Secumar - Bravo - 80-120 kg

**Rettungsweste - Feststoff**  
Notlicht - Pfeife - Reflexfolie

Typ: Secumar - Bravo - 80-120 kg



**Lifejacket - Foam**  
Light - Whistle - Reflective Tape  
packing dimensions: 50x9x28cm

1836652

type: Lalizas - Adult 43-140kg

**Rettungsweste - Feststoff**  
Notlicht - Pfeife - Reflexfolie  
Packmaß: 50x9x28cm

Typ: Lalizas - Erwachsene 43-140kg



**Lifejacket - Foam**  
Whistle - Reflective Tape  
packing dimensions: 55x13x38cm

1836662

type: Lalizas - Adult 43-140kg

**Rettungsweste - Feststoff**  
Pfeife - Reflexstreifen  
Packmaß: 55x13x38cm

Typ: Lalizas - Erwachsene 43-140kg



Foam Lifejackets  
Feststoffwesten



**Lifejacket - Foam**  
Whistle - Reflective Tape  
packing dimensions: 28x10x51cm

**1836833**

type: Lalizas - Child 15-43kg

**Rettungsweste - Feststoff**  
Pfeife - Reflexstreifen  
Packmaß: 28x10x51cm

Typ: Lalizas - Kind 15-43kg



**Lifejacket - Foam**  
Whistle - Reflective Tape  
packing dimensions: 12x32x38cm

**1836834**

type: Lalizas - Baby 0-15kg

**1836835**

type: Lalizas - Baby 0-15kg

**Rettungsweste - Feststoff**  
Pfeife - Reflexstreifen  
Packmaß: 12x32x38cm

Typ: Lalizas - Baby 0-15kg

Typ: Lalizas - Baby 0-15kg



**Lifejacket - Foam**  
Light - Whistle - Reflective Tape  
packing dimensions: 55x13x38cm

**1836853**

type: Lalizas - Child 15-43kg

**Rettungsweste - Feststoff**  
Notlicht - Pfeife - Reflexstreifen  
Packmaß: 55x13x38cm

Typ: Lalizas - Kind 15-43kg



**Lifejacket - Foam**  
Whistle - Reflective Tape  
according to DINISO 12402-3

**1836855**

type: Navimo - Typhoon - XL - 150N

**Rettungsweste - Feststoff**  
Pfeife - Reflexfolie  
gemäss DINISO 12402-3

Typ: Navimo - Typhoon - XL - 150N

Inflatable Lif jackets  
aufblasbare Westen



**Lif jacket - inflatable**  
DIN EN 399 / DIN EN ISO 12402-2  
Sleeve from Preoxii  
Para-Aramid Fabrics  
flame-adversely according to DIN  
EN 394

**1835902**

type: Kadematic 275 AF 2

**Rettungsweste - aufblasbar**  
DIN EN 399 / DIN EN ISO 12402-2  
Schutzhülle aus Preox  
Para-Aramid-Gewebe  
flammwidrig nach DIN EN 394

Typ: Kadematic - 275 AF 2



**Lif jacket - inflatable**  
DIN EN 399 / DIN EN ISO 12402-2

**1835903**

type: Kadematic 275 AF 1 - red

**Rettungsweste - aufblasbar**  
DIN EN 399 / DIN EN ISO 12402-2

Typ: Kadematic - 275 AF 1 - rot



**Lif jacket - inflatable**  
Whistle - Reflective Tape

**1835904**

type: Kadematic - Nova 150 AHR -  
black/grey

**Rettungsweste - aufblasbar**  
Pfeife - Reflexfolie

Typ: Kadematic - Nova 150 AHR -  
schwarz/grau



**Lif jacket - inflatable**  
Whistle - Reflective Tape

**1835905**

type: Kadematic 275 ALR - blue

**Rettungsweste - aufblasbar**  
Pfeife - Reflexfolie

Typ: Kadematic - 275 ALR - blau

Inflatable Lifejackets  
*aufblasbare Westen*



**Lifejacket - inflatable**  
CE Norm

**1835906**

type: Kadematic 275 A - red

**Rettungsweste - aufblasbar**  
CE Norm

Typ: Kadematic - 275 A - rot



**Lifejacket - inflatable**  
for body weight 50-120kg

**1835907**

type: Kadematic - 15 BG SV - red - 150N

**Rettungsweste - aufblasbar**  
Körpergewicht 50-120kg

Typ: Kadematic - 15 BG SV - rot - 150N



**Lifejacket - inflatable**  
EN 396/EN ISO 12402-3

**1835908**

type: Kadematic - Alterna AL- blue - 150N

**Rettungsweste - aufblasbar**  
EN 396/EN ISO 12402-3  
150N

Typ: Kadematic - Alterna AL- blau



**Lifejacket - inflatable**  
Light - Whistle - Reflective Tape  
MED - Approval  
Automatic - 22 litre buoyancy

**1835909**

Typ: Kadematic - 275 SOLAS AH - Twin Chamber

**Rettungsweste - aufblasbar**  
Notlicht - Pfeife - Reflexfolie  
MED - Zulassung  
Automatik - 22 Liter Auftriebskörper

Typ: Kadematic - 275 SOLAS AH - Doppelkammer



Inflatable Lifejackets  
aufblasbare Westen

**Lifejacket - inflatable**  
Light - Whistle - Reflective Tape  
MED - Approval  
170N Buoyancy

**1835910**

type: Kadematic - SOLAS 15N -  
Twin Chamber

**Rettungsweste - aufblasbar**  
Notlicht - Pfeife - Reflexfolie  
MED - Zulassung  
170N Auftriebskörper

Typ: Kadematic - SOLAS 15N -  
Doppelkammer



**Lifejacket - inflatable**  
DIN EN ISO 12402-3  
EN 530 (abrasion resistance)  
EN 348 (molten metal spatter)  
EN 863 (puncture resistance)  
EN 6529 (chemical resistance)

**1835911**

type: Kadematic 15 BG/HD -  
Welding

**Rettungsweste - aufblasbar**  
DIN EN ISO 12402-3  
EN 530 (Abriebfestigkeit),  
EN 348 (Metallspritzer),  
EN 863 (Stichfestigkeit)  
EN 6529 (chemische Beständigkeit)

Typ: Kadematic 15 BG/HD -  
Schweißen



**Lifejacket - inflatable**  
Light - Whistle - Reflective Tape  
MED - Approval  
22 litre Buoyancy

**1835912**

type: Secumar - Golf 150 Twin -  
Twin Chamber

**Rettungsweste - aufblasbar**  
Notlicht - Pfeife - Reflexfolie  
MED - Zulassung  
22 Liter Auftriebskörper

Typ: Secumar - Golf 150 Twin -  
Doppelkammer

**1835912**

type: Secumar - Golf 150 Twin -  
Twin Chamber

Typ: Secumar - Golf 150 Twin -  
Doppelkammer



**Lifejacket - inflatable**  
DIN-ISO 12402-3  
Automatic, 170 N Buoyancy  
use for BGR 201

**1835913**

type: Kadematic 15 BG - metalized

**Rettungsweste - aufblasbar**  
DIN-ISO 12402-3  
Automatik, 170 N Auftrieb,  
Einsatz in Bereich BGR 201

Typ: Kadematic 15 BG - metallisiert

Inflatable Lifejackets  
aufblasbare Westen



**Lifejacket - inflatable**

**1836100**

type: Secumar - Golf 150 - blue

**Rettungsweste - aufblasbar**

Typ: Secumar - Golf 150 - blau



**Lifejacket - inflatable**  
Welding Protection - orange

**1836400**

type: Secumar - Golf 150 SPR -  
Welding

**Rettungsweste - aufblasbar**  
Schweißschutz - orange

Typ: Secumar - Golf 150 SPR -  
Schweißen



**Lifejacket - inflatable**  
DIN EN ISO 12402 Teil 6  
RheinSchUO

**1836401**

type: Secumar - O.R.A. 100 Hand

**Rettungsweste - aufblasbar**  
DIN EN ISO 12402 Teil 6  
RheinSchUO

Typ: Secumar - O.R.A. 100 Hand





**Survival Suit**

extra large size  
body length up to 210cm  
belly size up to 175cm  
MED approved  
with carrying bag - 60x38x20cm  
PB-version

1842878

type: Bora - Jumbo

**Überlebensanzug**

Übergröße  
Körpergröße bis 210cm  
Bauchumfang bis 175cm  
MED Zulassung  
in Packtasche 60x38x20cm  
PB - Version

Typ: Bora - Jumbo



**Survival Suit**

universal size  
body length 160-190cm  
MED approved  
with carrying bag - 60x38x20cm  
PB-version

1842879

type: Bora

**Überlebensanzug**

Universalgröße  
(Körpergröße 160-190cm)  
MED Zulassung  
in Packtasche 60x38x20cm  
PB - Version

Typ: Bora



**Survival Suit**

size L  
Manufacturer: Mullion  
without neck pillow  
MED approved  
in carrying bag - 60x38x22cm

1842905

type: Smart Solas Suit 2A - SSS2A

**Überlebensanzug**

Größe L  
Hersteller: Mullion  
ohne Nackenkissen  
MED Zulassung  
in Packtasche 60x38x22cm

Typ: Smart Solas Suit 2A - SSS2A



**Survival Suit**  
without neck pillow  
Neoprene: 5mm  
MED approved  
in carrying bag

**1843110**

Aquata - ARO V20 OP - 185  
(165-190cm)

**1843120**

Aquata - ARO V20 OP - 165  
(140-165cm)

**1843130**

Aquata - ARO V20 OP - 205  
(185-205cm)

**Überlebensanzug**  
ohne Nackenkissen  
Neopren: 5mm  
MED Zulassung  
in Packtasche

Aquata - ARO V20 OP - 185  
(165-190cm)

Aquata - ARO V20 OP - 165  
(140-165cm)

Aquata - ARO V20 OP - 205  
(185-205cm)



**Survival Suit**  
with neck pillow  
Neoprene: 5mm  
MED approved  
in carrying bag

**1843150**

Aquata - ARO V20 - 185  
(165-190cm)

**1843160**

Aquata - ARO V20 - 165  
(140-165cm)

**Überlebensanzug**  
mit Nackenkissen  
Neopren: 5mm  
MED Zulassung  
in Packtasche

Aquata - ARO V20 - 185  
(165-190cm)

Aquata - ARO V20 - 165  
(140-165cm)



**DSB - Liferaft - EP "A"**  
droppable  
with cradle  
Hydrostatic Release  
in accordance with:  
SOLAS 74/96 and LSA Code  
max. release height 25m

**1801200**

type: LR07-MED-SOLAS / 6  
Persons

**1801220**

type: LR07-MED-SOLAS / 8  
Persons

**1801230**

type: LR07-MED-SOLAS / 10  
Persons

**1801260**

type: LR07-MED-SOLAS / 12  
Persons

**1801300**

type: LR07-MED-SOLAS / 16  
Persons

**1801320**

type: LR97-MED-SOLAS / 20  
Persons

**1801340**

type: LR97-MED-SOLAS / 25  
persons

**DSB - Rettungsinsel - EP  
"A"**  
abwerfbar  
mit Lagergestell  
Wasserdruckauslöser  
gemäß:  
SOLAS 74/96 und LSA Code  
max. Abwurfhöhe 25m

Typ: LR07-MED-SOLAS / 6  
Personen

Typ: LR07-MED-SOLAS / 8  
Personen

Typ: LR07-MED-SOLAS / 10  
Personen

Typ: LR07-MED-SOLAS / 12  
Personen

Typ: LR07-MED-SOLAS / 16  
Personen

Typ: LR07-MED-SOLAS / 20  
Personen

Typ: LR07-MED-SOLAS / 25  
Personen



**DSB - Liferaft - EP "A"**  
launchable  
with cradle  
Hydrostatic Release  
in accordance with:  
SOLAS 74/96 and LSA Code  
max. release height 25m

**1801450**

type: LR07L-MED-SOLAS / 12  
Persons

**1801460**

type: LR07L-MED-SOLAS / 16  
Persons

**1801461**

type: LR07L-MED-SOLAS / 25  
Persons

**1801462**

type: LR05L-MED-SOLAS / 20  
Persons

**DSB - Rettungsinsel - EP  
"A"**  
fließbar  
mit Lagergestell  
Wasserdruckauslöser  
gemäß:  
SOLAS 74/96 und LSA Code  
max. Abwurfhöhe 25m

Typ: LR07L-MED-SOLAS / 12  
Personen

Typ: LR07L-MED-SOLAS / 16  
Personen

Typ: LR07L-MED-SOLAS / 25  
Personen

Typ: LR07L-MED-SOLAS / 20  
Personen



**Lifebuoy**  
Hard Shell, Reflective Tape,  
Grapeline  
orange - 45x75cm  
according to:  
MED - EN14144 - SOLAS 74  
release height: up to 60m

**1831403**

type: PB-Buoy - 4,2kg

**1831404**

type: PB-Buoy - 2,5kg

**Rettungsring**  
Hartschale, Reflex, Greifleine  
Orange, 45x75cm  
Zulassungen:  
MED - EN14144 - SOLAS 74  
Abwurfhöhe: bis 60m

Typ: PB-Buoy - 4,2kg

Typ: PB-Buoy - 2,5kg



**Lifebuoy**  
Grapeline - white  
9,0 daN  
for Leisure Shipping

**1831405**

60x34x10cm - red/white - plastic  
cover

**Rettungsring**  
Greifleine - weiß  
9,0 daN  
Sportschifffahrt

60x34x10cm - rot/weiß -  
Kunststoffbezug



**Lifebuoy**  
Grapeline - white  
9,8 daN  
for the Leisure Shipping

**1831406**

60x38x10cm - red/white - painted

**Rettungsring**  
Greifleine - weiß  
9,8 daN  
für die Sportschifffahrt

60x38x10cm - rot/weiß - lackiert



**Rescue Apparatus**  
orange  
in accordance with §15.09

**1833300**

120x120x25cm - 10 persons

**1833302**

90x90x15cm - 8 Persons



**Rescue Apparatus**  
orange  
in accordance with §15.09

**1833301**

152x46x15cm - 10 Persons

**Sammelrettungsgerät**  
orange  
in Übereinstimmung mit § 15.09

120x120x25cm - 10 Personen

90x90x15cm - 8 Personen

**Sammelrettungsgerät**  
orange  
in Übereinstimmung mit § 15.09

152x46x15cm - 10 Personen



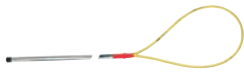

**Rescue Rod**  
loop diameter: 500mm  
Aluminium - swimming

**3833900**

bar length: 3m - with grapline

**3834000**

bar length: 6m - with grapline

**Rettungsstange**

Schlingendurchmesser: 500mm  
Aluminium - schwimmend

Stangenlänge: 3m - mit  
Greifschlinge

Stangenlänge: 6m - mit  
Greifschlinge



**Rescue Rod**  
loop diameter: 500mm  
Aluminium - swimming

**3834090**

bar length: 3m - with grapring

**3834100**

bar length: 6m - with grapring

**Rettungsstange**

Ringdurchmesser: 500mm  
Aluminium - schwimmend

Stangenlänge: 3m - mit festem  
Greifring

Stangenlänge: 6m - mit festem  
Greifring



**Rescue Throwing Ball**  
28cm - white  
hard foam with ring

**3834105**

with grip net

**Rettungswurfball**

28cm - weiß  
Hartschaum mit Kausche

mit Griffnetz



**Throwing Ball**

**3834106**

28cm - hard foam with ring

**Wurfball**

28cm - Hartschaum mit Kausche



**Throwing Ball Net**

**3834107**

for 28cm throwing ball

**Wurfballnetz**

für Wurfball 28cm



**Bracket for Rescue Rod**  
stainless steel

1411200

pair

**Halter für Rettungsstange**  
Edelstahl

Paar



**Hydrostatic Release**

1420600

type: Hammar H20 - for liferaft

**Wasserdruckauslöser**

Typ: Hammar H20 - für  
Rettungsinsel



**Hydrostatic Release**

1420700

type: Hammar H20 - for Epirb

**Wasserdruckauslöser**

Typ: Hammar H20 - für Epirb



**Hydrostatic Release**

1420750

type: HRU McMurdo - Epirb

**Wasserdruckauslöser**

Typ: HRU McMurdo - Epirb



**Signaling Whistle**  
for Lifejackets

1445000

with lanyard

**Signalpfeife**  
für Rettungswesten

mit Band

1445010

without lanyard

ohne Band



**Pelican Hook**

1801100

130mm - brass

**Pelikanhaken**

130mm - Messing



**Pelican Hook**

**1801110**

125mm - stainless steel

**Pelikanhaken**

125mm - Edelstahl



**CO<sup>2</sup> - Pressure Cartridge**  
for inflatable Lifejackets

**1836201**

Kadematic - 32gr. - 2 tablets + 2 pins

**CO<sup>2</sup> - Patrone**  
aufblasbare Rettungswesten

Kadematic - 32gr. - 2 Tabletten + 2 Pins



**CO<sup>2</sup> - Pressure Cartridge**  
for inflatable Lifejackets

**1836220**

Secumar - 32gr. - 2 tablets - bayonet

**CO<sup>2</sup> - Patrone**  
für aufblasbare Rettungswesten

Secumar - 32gr. - 2 Tabletten - Bayonett



**CO<sup>2</sup> - Pressure Cartridge**  
for inflatable Lifejackets

**1837350**

Secumar - 56gr. - 2 tablets - bayonet

**CO<sup>2</sup> - Patrone**  
für aufblasbare Rettungswesten

Secumar - 56gr. - 2 Tabletten - Bayonett



**Test - Kit**

**1843281**

for survival suits

**Test - Set**

für Überlebensanzüge



**Double Stroke Air Pump**

**1843310**

**Doppelhubpumpe**



**MOB - Quick Release**

**1931300**  
fibreglass

**MOB - Rutsche**

Fiberglas



**Lifebuoy Bracket**  
without reeling mounting set

**3831010**  
EN14145-B - aluminium

**Rettungsringhalter**  
ohne Reeling Befestigungsset

EN14145-B - Aluminium



**Mounting Set - Reeling**

**3831011**  
for lifebuoy bracket

**Befestigungssatz - Reeling**

für Rettungsringhalter



**Lifebuoy Bracket**  
3 pieces - steel

**3832700**  
DIN 83453-A

**Rettungsringhalter**  
3-teilig - Stahl

DIN 83453-A



**Mounting Bracket - Set**  
galvanized steel

**3855600**  
for MOB slide

**Montage - Winkel - Set**  
Stahl feuerverzinkt

für MOB Rutsche

Emergency Lights  
Notlichter



**Emergency Light**  
manually- / water activated  
MED approval

1843801

type: Rescue - DAN W3 - LED

**Notlicht**  
Manuell- / Wasseraktiviert  
MED Zulassung

Typ: Rescue - DAN W3 - LED



**Emergency Light**  
manually- / water activated  
MED approval

1843802

type: Kadematic - SLX Modell C

**Notlicht**  
Manuell- / Wasseraktiviert  
MED Zulassung

Typ: Kadematic - SLX Modell C

Life Buoy Lights  
Nachtlichter



**Lifebuoy Light**  
with bracket  
water activated

1931681

type: Daniamant L161 - ex-proof

**Nachtlicht**  
mit Halter  
wasseraktiviert

Typ: Daniamant L161 - ex-geschützt



**Lifebuoy Light**  
with bracket  
with batteries  
Release height: up to 60m  
MED approval

1931721

type: Mariner

**Nachtlicht**  
mit Halter  
mit Batterien  
Abwurfhöhe: bis 60m  
MED Zulassung

Typ: Mariner



**Lifebuoy Light**  
with batteries  
Release height: up to 60m  
MED approval

1932021

type: Mariner

**Nachtlicht**  
mit Batterien  
Abwurfhöhe: bis 60m  
MED Zulassung

Typ: Mariner



**Lifebuoy Light**  
with batteries

1932022

type: KTR - LED

**Nachtlicht**  
mit Batterien

Typ: KTR - LED





Life Buoy Lights  
*Nachtlichter*

**Bulb**  
for lifebuoy light

**1932600**

4 Volt - 0,6 Amp - E10

**Glühlampe**  
für Nachtlicht

4 Volt - 0,6 Amp - E10



**Bracket for Lifebuoy Light**  
plastic

**1933631**

type: Mariner

**Halter für Nachtlicht**  
Kunststoff

Typ: Mariner



**Bracket for Lifebuoy Light**  
stainless steel

**3330400**

type: universal

**Halter für Nachtlicht**  
Edelstahl

Typ: universal



**Pipe Clamps - Set**  
D=25mm - stainless steel  
with screws

**3330900**

for lifebuoylight bracket

**Rohrschellen - Set**  
D=25mm - Edelstahl  
Paar mit Schrauben

für Nachtlichterhalter



Personal Protective  
Equipment

*Persönliche  
Schutzausrüstung*

Gas Protective Suits  
Anzüge Gasschutz



**Chemical Protective Suit**

orange - with hood  
SOLAS/GL approval  
Dräger R57377

**1810110**

type: SPC3800 - size XL - light duty

**Chemikalien-Schutzanzug**

orange - mit Kapuze  
SOLAS/GL zugelassen  
Dräger R57377

Typ: SPC3800 - Größe XL - leichte Ausführung



**Chemical Protective Overall**

with hood  
light version

**1810120**

size: S - PVC - green

**1810130**

size: XL - PVC - green

**Chemikalien-Schutzoverall**

mit Kapuze  
leichte Ausführung

Größe: S - PVC - grün

Größe: XL - PVC - grün



**Chemical Protective Overall**

with hood  
extra light version

**1810140**

type: Jetguard - size XL

**1810150**

type: Jetguard - size XXL

**Chemikalien-Schutzoverall**

mit Kapuze  
extra leichte Ausführung

Typ: Jetguard - Größe XL

Typ: Jetguard - Größe XXL



**Chemical Protective Overall**

class type: 4.5 and 6 - EN 368  
breathing active  
elastic strip at arms, hood, legs  
with tapable chin cover plate,  
zipper

**1810151**

type: Protec Plus - size XL

**Chemikalien-Schutzoverall**

Klasse Typ: 4.5 und 6 - EN368  
Atmungsaktiv  
Gummizug an Armel, Haube, Bein  
abklebbare Kinn-Abdeckblende,  
Reißverschluss

Typ: Protec Plus - Größe XL

Gas Protective Suits  
Anzüge Gasschutz



**Chemical Protective Suit**  
with integrated visor  
MED 2002/75/EC  
EN 943-1:2002, Typ 1a.  
EN 943-2:2002  
vfdb-Requirement 08/02:2002-11

**1812500**

type: TeamMaster pro-ET - size: L - blue

**1812510**

type: TeamMaster pro-ET - size: XL - blue

**Chemikalien-Schutzanzug**  
fest eingebaute Sichtscheibe  
MED 2002/75/EC  
EN 943-1:2002, Typ 1a.  
EN 943-2:2002  
vfdb-Richtlinie 08/02:2002-11

Typ: TeamMaster pro-ET - Größe L - blau

Typ: TeamMaster pro-ET - Größe XL - blau



**Chemical Protective Suit**  
with integrated full mask  
EN 943-1:2002, Typ 1a. EN 943-2:2002  
MED 2002/75/EC

**1841380**

type: TeamMaster pro-ET - M - blue

**1841390**

type: WorkMaster pro-ET - L - blue

**1841400**

type: WorkMaster pro-ET - XL - blue

**Chemikalien-Schutzanzug**  
mit integrierter Vollmaske  
EN 943-1:2002, Typ 1a. EN 943-2:2002  
MED 2002/75/EC

Typ: TeamMaster pro-ET - M - blau

Typ: WorkMaster pro-ET - L - blau

Typ: WorkMaster pro-ET - XL - blau



**Chemical Protective Suit**  
heavy duty  
open face  
with gastight zipper  
SOLAS/GL approval

**1841090**

type: Berlin - size: XL

**1841100**

type: Berlin - size: universal

**Chemikalien-Schutzanzug**  
Schwere Ausführung  
offenen Gesichtsfeld  
gasdichter Reißverschluss  
SOLAS/GL - Zulassung

Typ: Berlin - Größe: XL

Typ: Berlin - Größe: universal



**Chemical Protective Suit**  
open face  
GL/SOLAS - approval  
EN-typeclass: Kat. III-EN 943  
Part 1 Industrie

**1841110**

type: Sea Safety 30 - Dynat - size: universal

**Chemikalien-Schutzanzug**  
Offenes Gesichtsfeld  
GL/SOLAS - Zulassung  
EN-Typenklasse: Kat. III-EN 943  
Teil 1 Industrie

Typ: Sea Safety 30 - Dynat - Größe: universal





Gas Protective Suits  
Anzüge Gasschutz

**Chemical Protective Suit**

open face  
MED - approval

1841111

type: Sea Safety 1 - size: universal

**Chemikalien-Schutzanzug**

Offenes Gesichtsfeld  
MED - Zulassung

Typ: Sea Safety 1 - Größe:  
universal



**Chemical Protective Suit**

wear breathing apparatus outside  
according to requirements  
EN943-1+2:2000  
SOLAS conventions

1841120

type: Dräger CPS 5800 XL

**Chemikalien-Schutzanzug**

für außen zu tragenden Atmer  
nach Anforderungen EN  
943-1+2:2002  
SOLAS-Konventionen

Typ: Dräger CPS 5800 XL



**Chemical Protective Suit**

with integrated full mask  
EN 943-1:2002, Typ 1a.  
EN 943-2:2002  
MED 2002/75/EC

1841340

type: Teammaster pro-ET - M -  
orange

**Chemikalien-Schutzanzug**

mit integrierter Vollmaske  
EN 943-1:2002, Typ 1a.  
EN 943-2:2002  
MED 2002/75/EC

Typ: TeamMaster pro-ET - M -  
orange

1841350

type: Teammaster pro-ET - L -  
orange

Typ: TeamMaster pro-ET - L -  
orange

1841360

type: Teammaster pro-ET - XL-  
orange

Typ: TeamMaster pro-ET - XL -  
orange



**Chemical Protective Suit**

open face  
EN 943-1:2002, Typ 1a.  
EN 943-2:2002  
MED 2002/75/EC

1841430

type: WorkMaster pro-ET - M -  
orange

**Chemikalien-Schutzanzug**

offenes Gesichtsfeld  
EN 943-1:2002, Typ 1a.  
EN 943-2:2002  
MED 2002/75/EC

Typ: WorkMaster pro-ET - M -  
orange

1841450

type: WorkMaster pro-ET - L -  
orange

Typ: WorkMaster pro-ET - L -  
orange

1841470

type: WorkMaster pro-ET - XL -  
orange

Typ: WorkMaster pro-ET - XL -  
orange



## Gas Protective Suits *Anzüge Gasschutz*



### **Chemical Protective Suit**

open face  
EN 943-1:2002, Typ 1a.  
EN 943-2:2002  
MED 2002/75/EC

**1841510**

type: WorkMaster pro-ET - M - blue *Typ: WorkMaster pro-ET - M - blau*

**1841530**

type: WorkMaster pro-ET - L - blue *Typ: WorkMaster pro-ET - L - blau*

**1841550**

type: WorkMaster pro-ET - XL - blue *Typ: WorkMaster pro-ET - XL - blau*

### **Chemikalien-Schutzanzug**

offenes Gesichtsfeld  
EN 943-1:2002, Typ 1a.  
EN 943-2:2002  
MED 2002/75/EC

## Accessories Gas Protection *Zubehör Gasschutz*



### **Steatin Stick**

**1824100**

for zipper service

### **Steatinstift**

für Reißverschlusspflege



Helmets  
Helme

**Safety Helmet**

1810900

type: North - EN 397 - white

**Arbeitsschutzhelm**

Typ: - EN 397 - weiß



**Safety Helmet**

1810910

type: North - EN 397 - yellow

**Arbeitsschutzhelm**

EN 397 - gelb



**Safety Helmet**

1810920

type: North - EN 397 - blue

**Arbeitsschutzhelm**

Typ: EN 397 - blau



**Safety Helmet**

1810930

type: North - EN 397 - red

**Arbeitsschutzhelm**

EN 397 - rot



**Safety Helmet**

1811000

type: North - EN 397 - orange

**Arbeitsschutzhelm**

EN 397 - orange



**Sweatband**

1811600

for North Safety Helmet

**Schweißband**

für North Arbeitsschutzhelm



**Electrician Helmet**

1842450

according to VDE

**Schutzhelm für Elektriker**

gemäß VDE

Helmets  
Helme



**Firefighter Helmet**  
with neck protection and visor  
MED approval

**1896101**

type: Fuego

**Feuerschutzhelm**  
mit Nackenschutz und Visier  
MED Zulassung

Typ: Fuego



**Firefighter Helmet**  
according to: EN 443:2008  
MED approval

**1896102**

type: F120 H2

**Feuerschutzhelm**  
gemäss EN 443:2008  
MED Zulassung

Typ: F120 H2



**Neck Protection**

**1896103**

for firefighter helmet

**Nackenschutz**

für Feuerwehrhelm



**Visor**

**1896104**

for firefighter helmet

**Visier**

für Feuerschutzhelm

Boots  
Schuhe



**Wellington Boots**  
with steel-toe protection  
and non-pierceable sole

**1811400**

EN 345 - S5 - size 40

**1811410**

EN 345 - S5 - size 41

**1811420**

EN 345 - S5 - size 42

**1811430**

EN 345 - S5 - size 43

**1811440**

EN 345 - S5 - size 44

**1811450**

EN 345 - S5 - size 45

**Gummistiefel**  
mit Stahlkappe  
mit durchtrittssichere Sohle

EN 345 - S5 - Größe 40

EN 345 - S5 - Größe 41

EN 345 - S5 - Größe 42

EN 345 - S5 - Größe 43

EN 345 - S5 - Größe 44

EN 345 - S5 - Größe 45



Boots  
Schuhe

**Safety Shoes**  
black

1811540

EN 345-1 - S3 - size 41

1811550

EN 345-1 - S3 - size 42

1811560

EN 345-1 - S3 - size 43

1811570

EN 345-1 - S3 - size 44

1811580

EN 345-1 - S3 - size 45

**Arbeitssicherheitsschuhe**  
schwarz

EN 345-1 - S3 - Größe 41

EN 345-1 - S3 - Größe 42

EN 345-1 - S3 - Größe 43

EN 345-1 - S3 - Größe 44

EN 345-1 - S3 - Größe 45



**Wellington Boots**

1841800

for firemans outfit - size 45

**Gummistiefel**

für Hitzeschutzanzug - Größe 45

Gloves  
Handschuhe



**Acid Glove**

1810200

short

**Säureschutzhandschuhe**

kurz



**Acid Glove**

1810250

long

**Säureschutzhandschuhe**

lang



**Chemical Glove**

Lattice profile in the interior hand,  
32 cm long,  
EN 388 and 374 - category 3

1810290

material: Nitrile - long

**Chemikalienschutzhandschuhe**

Gitterprofil in der Innenhand,  
32 cm lang,  
EN 388 und 374 - Kategorie 3

Material: Nitril - lang

Gloves  
Handschuhe



**Heat Glove**

1840100

material: Kevlar - long

**Hitze - Schutzhandschuhe**

Material: Kevlar - lang



**Heat Glove**

heat protection up to 350 °C

1840120

material: Kevlar /aluminized/leather

**Hitze - Schutzhandschuhe**

Hitzebeständigkeit 350 °C

Material: Kevlar/aluminisiert



**Working Glove**

1840190

material: pigskin

**Arbeitshandschuhe**

Material: Schweinsleder



**Working Glove**

1840193

type: Hy-Flex 11-801 - size 9

**Arbeitshandschuhe**

Typ: Hy-Flex 11-801 - Größe 9



**Welding Glove**

1840220

material: leather - with long gauntlet

**Schweißerhandschuh**

Material: Leder - mit langer Stulpe



**Budget Glove**

1840230

**Gummihandschuhe**





Gloves  
Handschuhe

**Cotton Gloves**

1840240

with PVC studs

**Baumwollhandschuhe**

mit PVC-Noppen



**Electrician Glove**

1842400

test voltage up to 1000 V

**Elektriker - Handschuhe**

Prüfspannung 1000V

Clothes  
Kleidung



**Workingoverall**

1811510

Material: 100% Cotton - blue

**Arbeitsoverall**

Material: 100% Baumwolle - blau



**Pilot Jacket**  
integrated Lifejacket - 150N  
long version

1811761

type: 1MKM

**Lotsenjackete**  
mit integrierter Rettungsweste  
mit 150N Auftrieb  
Lange Version

Typ: 1MKM

Clothes  
Kleidung



**Disposable Overall**

1880270

white - with hood - XXL

**Einweg - Overall**

weiß - mit Kapuze - XXL

Gehörschutz - Ear Protection



**Ear Plugs**

1811900

type: Tri-Flange with lanyard

**Gehörschutzstöpsel**

Typ: Tri-Flange mit Band



**Ear Plugs**

1811910

Pura-Fit

**Gehörschutzstöpsel**

Pura-Fit



**Ear Muff**

SNR value: 23 dB

1812000

EN 352-1

**Gehörschutzmuscheln**

SNR-Wert: 23 dB

EN 352-1



**Ear Muff**

EN 352-1

SNR value: 27 dB

- specially broad head handle
- springy handle wires from stainless spring steel
- suspension of point of two
- stepless vertical adjustment
- spreads, soft gaskets
- versatile and easily
- gaskets filled with glycerin

1812001

type: 3M "Peltor" Optime I

**Kapselgehörschützer**

EN 352-1

SNR-Wert: 27 dB

- extra breiter Kopfbügel
- federnde Bügeldrähte aus rostfreiem Federstahl
- Zweipunkt-Aufhängung
- stufenlose Höhenverstellung
- breite, weiche Dichtungsringe
- vielseitig und leicht
- Dichtungsringe mit Glycerin gefüllt

Typ: 3M "Peltor" Optime I

Gehörschutz - Ear Protection



**Ear Muff**

- EN 352-1  
SNR value: 31 dB
- extra wide head clamp
  - spring clamp wires made of rust-free spring steel
  - 2 point suspension
  - infinite height adjustment
  - wide, soft sealing rings
  - for strong noise load

1812002

type: 3M "Peltor" Optime II

**Kapselgehörschützer**

- EN 352-1  
SNR-Wert: 31 dB
- extra breiter Kopfbügel
  - federnde Bügeldrähte aus rostfreiem Federstahl
  - Zweipunkt-Aufhängung
  - stufenlose Höhenverstellung
  - breite, weiche Dichtungsringe
  - für starke Lärmbelastung

Typ: 3M "Peltor" Optime II



**Ear Muff**

- EN 352-1  
SNR value: 35 dB
- extra wide head clamp
  - spring clamp wires made of rust-free spring steel
  - 2 point suspension
  - infinite height adjustment
  - wide, soft sealing rings
  - for extreme noise load

1812003

type: 3M "Peltor" Optime III

**Kapselgehörschützer**

- EN 352-1  
SNR-Wert: 35 dB
- extra breiter Kopfbügel
  - federnde Bügeldrähte aus rostfreiem Federstahl
  - Zweipunkt-Aufhängung
  - stufenlose Höhenverstellung
  - breite, weiche Dichtungsringe
  - für extreme Lärmbelastung

Typ: 3M "Peltor" Optime III



**Ear Muff**

- EN 352-1  
SNR value: 31 dB
- extra wide head clamp
  - spring clamp wires made of rust-free spring steel
  - 2 point suspension
  - infinite height adjustment
  - wide, soft sealing rings
  - for strong noise load

1812004

Typ: 3M "Peltor" Optime II PTL (Push to Listen)

**Kapselgehörschützer**

- EN 352-1  
SNR-Wert: 31 dB
- extra breiter Kopfbügel
  - federnde Bügeldrähte aus rostfreiem Federstahl
  - Zweipunkt-Aufhängung
  - stufenlose Höhenverstellung
  - breite, weiche Dichtungsringe
  - für starke Lärmbelastung

Typ: 3M "Peltor" Optime II PTL (Push to Listen)



**Ear Muff - with helmet adapter**

- EN 352-1  
SNR value: 27 dB
- specially broad head handle
  - springy handle wires from stainless spring steel
  - Suspension of point of two
  - stepless vertical adjustment
  - spreads, soft gaskets
  - versatile and easily
  - gaskets filled with glycerin

1812005

type: 3M "Peltor" Optime I - P3E

**Kapselgehörschützer - mit Helmadapter**

- EN 352-1  
SNR-Wert: 27 dB
- extra breiter Kopfbügel
  - federnde Bügeldrähte aus rostfreiem Federstahl
  - Zweipunkt-Aufhängung
  - stufenlose Höhenverstellung
  - breite, weiche Dichtungsringe
  - vielseitig und leicht
  - Dichtungsringe mit Glyzerin gefüllt

Typ: 3M "Peltor" Optime I - P3E

*Gehörschutz - Ear Protection*



**Ear Muff - with helmet adapter**

- EN 352-1  
SNR value: 31 dB
- extra wide head clamp
  - spring clamp wires made of rust-free spring steel
  - 2 point suspension
  - infinite height adjustment
  - wide, soft sealing rings
  - for strong noise loa

**1812006**

type: 3M "Peltor" Optime II - P3E

**Kapselgehörschützer mit Helmadapter**

- EN 352-1  
SNR-Wert: 31 dB
- extra breiter Kopfbügel
  - federnde Bügeldrähte aus rostfreiem Federstahl
  - Zweipunkt-Aufhängung
  - stufenlose Höhenverstellung
  - breite, weiche Dichtungsringe
  - für starke Lärmbelastung

Typ: 3M "Peltor" Optime II - P3E



**Ear Muff - with helmet adapter**

- EN 352-1  
SNR value: 35 dB
- extra wide head clamp
  - spring clamp wires made of rust-free spring steel
  - 2 point suspension
  - infinite height adjustment
  - wide, soft sealing rings
  - for extreme noise load

**1812007**

type: 3M "Peltor" Optime III

**Kapselgehörschützer mit Helmadapter**

- EN 352-1  
SNR-Wert: 35 dB
- extra breiter Kopfbügel
  - federnde Bügeldrähte aus rostfreiem Federstahl
  - Zweipunkt-Aufhängung
  - stufenlose Höhenverstellung
  - breite, weiche Dichtungsringe
  - für extreme Lärmbelastung

Typ: 3M "Peltor" Optime III - P3E



**Hygiene Set**

- including
- 2 foam material cushions
  - 2 gaskets

**1812008**

type: HY52 - für Optime II

**1812009**

type: HY54 - für Optime III

**Hygieneset**

- inklusive
- 2 Schaumstoffkissen
  - 2 Dichtungsringe

Typ: HY52 - für Optime II

Typ: HY54 - für Optime III

*Face Protection / Glasses*

*Sichtschutz / Brillen*



**Face Protection**

350 x 205 mm

**1811100**

with helmet bracket

**Gesichtsschutz**

350 x 205 mm

mit Helmhalterung



**Protective Goggles**

**1811300**

indirect ventilation

**Vollsichtschutzbrille**

indirekte Ventilation

Face Protection / Glasses  
Sichtschutz / Brillen



**Protective Goggles**  
indirect ventilation

1811301

type: 450 - EN 166 - CE 0196

**Vollsichtschutzbrille**  
indirekte Ventilation

Typ: 450 - EN 166 - CE 0196



**Protective Goggles**  
indirect ventilation

1811302

type: 446 - EN 166 - CE 0196

**Vollsichtschutzbrille**  
indirekte Ventilation

Typ: 446 - EN 166 - CE 0196



**Protective Goggles**  
without ventilation

1811303

type: 460 - EN 166 - CE 0196

**Vollsichtschutzbrille**  
ohne Ventilation

Typ: 460 - EN 166 - CE 0196



**Protective Goggles**  
grey, 2mm scratch resistant  
antifog

1811304

type: 627 - UV-protection

**Schutzbrille**  
grau, PC 2 mm kratzfest  
antifog

Typ: 627 - UV-Schutz



**Protective Goggles**

1811350

length adjustable arms

**Schutzbrille**

Bügel in der Länge verstellbar



**Sunglasses**  
protection class 5-2,5  
for wearing under a helmet

1811355

type: 3M - 2721

**Sonnenbrille**  
mit der Schutzstufe 5-2,5  
zum Tragen unter einem  
Schutzhelm

Typ: 3M-2721



**Face Protection**  
with bracket

1842500

for electrician helmet

**Gesichtsschutz**  
mit Halterung

für Elektriker-Schutzhelm



Masks / Filters  
Masken / Filter



**Dust Mask**

1510500

type: 8500 - coarse

**Staubmaske**

Typ: 8500 - grob



**Dust Mask**

with exhalation valve  
10 pieces/pack  
Dräger-No.: 39 51 088

1510550

type: X-Plore 1730 V

**Staubmaske**

mit Ausatemventil  
10 Stück/Pack  
Dräger-Nr.: 39 51 088

Typ: X-Plore 1730 V



**One Filter Respirator**

filter connection Rd40 (RA)  
Dräger-No.: R55876

1826750

type: X-plore 4740 TPE

**Einfilter Halbmaske**

Filterschraubverbindung Rd40 (RA)  
Dräger-Nr.: R55876

Typ: X-plore 4740 TPE



**One Filter Respirator**

filter connection Rd90  
Dräger-No.: R55879

1826760

type: X-plore 4790 TPE

**Einfilter Halbmaske**

Filterschraubverbindung Rd90  
Dräger-Nr.: R55879

Typ: X-plore 4790 TPE



**One Filter Respirator**

Dräger-No.: R55881

1826770

type: X-plore 2100 EPDM

**Einfilter Halbmaske**

Dräger-Nr.: R55881

Typ: X-plore 2100 EPDM

Masks / Filters  
Masken / Filter



**One Filter Respirator**  
Dräger-No.: R55332

**1826840**

type: X-plore 3300

**Zweifilter Halbmaske**  
Dräger-Nr.: R55332

Typ: X-plore 3300



**Two Filter Fullface Respirator**  
bajonet connection  
Dräger-No.: R55270

**1826850**

type: X-plore 5500

**Zweifilter Vollmaske**  
Bajonett Anschluss  
Dräger-Nr.: R55270

Typ: X-plore 5500



**Two Filter Respirator**  
Dräger-No.: R55352

**1826851**

type: X-plore 3500

**Zweifilter Halbmaske**  
Dräger-Nr.: R55352

Typ: X-plore 3500



**Particle Filter**  
22 pieces / package  
für mask X-plore 3300  
für mask X-plore 3500  
für mask X-plore 5500  
Dräger-No.: 6738011

**1826860**

type: Bajonett P3 R

**Partikelfilter**  
22 Stück / Packung  
für Maske X-plore 3300  
für Maske X-plore 3500  
für Maske X-plore 5500  
Dräger-Nr.: 6738011

Typ: Bajonett P3 R



**Combination Filter**  
14 pieces / package  
für mask X-plore 3300  
für mask X-plore 3500  
für mask X-plore 5500  
Dräger-No.: 6738874

**1826870**

type: Bajonett A1P3 RD

**Kombinationsfilter**  
14 Stück / Packung  
für Maske X-plore 3300  
für Maske X-plore 3500  
für Maske X-plore 5500  
Dräger-Nr.: Typ: 6738874

Typ: Bajonett A1P3 RD

Masks / Filters  
Masken / Filter



**Combination Filter**

14 pieces / package  
für mask X-plore 3300  
für mask X-plore 3500  
für mask X-plore 5500  
Dräger-No.: 6738817

**1826940**

type: Bajonett A1B1E1K1HgP3 RD *Typ: Bajonett A1B1E1K1HgP3 RD*

**Kombinationsfilter**

14 Stück / Packung  
für Maske X-plore 3300  
für Maske X-plore 3500  
für Maske X-plore 5500  
Dräger-Nr.: 6738817



**Gas Filter**

for mask X-plore 6300for mask X-  
plore 6530 PCfor mask X-plore  
6530 Triplexfor mask X-plore 6570  
PCfor mask X-plore 6570 Triplex

**1826941**

type: 1140 A2B2E2K2 - Rd40

**1846810**

Type: 940 A2B2E2K1 - Rd40

**Gasfilter**

für Maske X-plore 6300für Maske X-  
plore 6530 PCfür Maske X-plore  
6530 Triplexfür Maske X-plore 6570  
PCfür Maske X-plore 6570 Triplex

*Typ: 1140 A2B2E2K2 - Rd40*

*Typ: 940 A2B2E2K1 - Rd40*



**Two Filter Respirator**

3M-No.: 6200 (M)

**1827000**

type: 3M - 6000 - medium

**1827001**

type: 3M - 6000 - large

**1827002**

type: 3M - 6000 - small

**Zweifilter Halbmaske**

3M-Nr.: 6200 (M)

*Typ: 3M - 6000 - Medium*

*Typ: 3M - 6000 - Large*

*Typ: 3M - 6000 - Small*



**Two Filter Respirator**

3M-No.: 7501(S) - Silikon

**1827005**

type: 3M - 7500 - small

**1827006**

type: 3M - 7500 - medium

**1827007**

type: 3M - 7500 - large

**Zweifilter Halbmaske**

3M-Nr.:7501(S) - Silikon

*Typ: 3M - 7500 - Small*

*Typ: 3M - 7500 - Medium*

*Typ: 3M - 7500 - Large*



**Two Filter Respirator**

3M-No.:7002(M)

**1827008**

type: 3M - 7000 - medium

**1827009**

type: 3M - 7000 - large

**Zweifilter Halbmaske**

3M-Nr.:7002(M)

*Typ: 3M - 7000 - Medium*

*Typ: 3M - 7000 - Large*



**Two Filter Fullface Respirator**

bajonet connection  
3M - No.: 6800(M)

**1827010**

type: 3M - 6000 - Medium

**Zweifilter Silikon Vollmaske**

Bajonett Anschluss  
3M - Nr.: 6800(M)

*Typ: 3M - 6000 - Medium*

Masks / Filters  
Masken / Filter



**Particle Filter**  
for mask X-plore 6300  
for mask X-plore 6530 PC  
for mask X-plore 6530 Triplex  
for mask X-plore 6570 PC  
for mask X-plore 6570 Triplex  
for mask X-plore 4340  
for mask X-plore 4740  
for powered air respirator X-plore 7500  
Dräger-No.: 6732974

**1846600**

type: 1140 P3 R - Rd40

**Partikelfilter**  
für Maske X-plore 6300  
für Maske X-plore 6530 PC  
für Maske X-plore 6530 Triplex  
für Maske X-plore 6570 PC  
für Maske X-plore 6570 Triplex  
für Maske X-plore 4340  
für Maske X-plore 4740  
für Gebläsefiltergerät X-plore 7500  
Dräger-Nr.: 6738932

Typ: 1140 P3 R - Rd40



**Gas Filter Bajonett A2**  
20 pieces / package  
for mask X-plore 3300  
for mask X-plore 3500  
for mask X-plore 5500

**1846620**

Dräger-No.: 6738873

**Gasfilter Bajonett A2**  
20 Stück / Packung  
für Maske X-plore 3300  
für Maske X-plore 3500  
für Maske X-plore 5500

Dräger-Nr.: 6738873

Belts / Lines  
Gurte / Leinen



**Fire Brigade Safety Belt**  
with isolated rope  
DIN 14927

**1879020**

with two-thorn buckle

**Feuerwehr -  
Sicherheitsgurt**  
mit isolierter Sicherheitsleine  
DIN 14927

mit Zweidornschnalle



**Safety Waist Belt**  
for 100-110mm belly extent  
with belt 1,4m long - adjustable  
DIN-EN 358  
without backrest

**1892010**

type: B3R - 1500mm belt length

**1892020**

type: B3R - belt length 1400mm

**1892030**

type: B3R - belt length 1300mm

**Haltegurt**  
für 100-110cm Bauchumfang  
mit Gurtband 1,4m lang - verstellbar  
DIN-EN 358  
ohne Rückenstütze

Typ: B3R - Gurtlänge 1500mm

Typ: B3R - 1400mm Gurtlänge

Typ: B3R - 1300mm Gurtlänge



**Safety Device Rope**  
carabiner MAS51 and loop  
DIN-EN 354 i.a.

**1892300**

polyamid rope 12mm - 10m

**Sicherungsseil**  
mit Karabinerhaken MAS51 und  
Schlaufe  
DIN-EN 354 i.a.

Polyamid-Seil 12mm - 10m

Belts / Lines  
Gurte / Leinen



**Safety Line**  
fire-resistant - orange  
MED-approval

**1892350**

type: Flammschutz - 30m / 10mm

**Sicherheitsleine**  
feuerfest - orange  
MED-Zulassung

Typ: Flammschutz - 30m / 10mm



**Safety Line**  
fire-resistant - 1 thimble  
steel insert  
MED-approved

**1892390**

type: Herkules - 45m / 10mm

**1892400**

type: Herkules - 30m / 10mm

**Sicherheitsleine**  
feuerfest - mit 1 Kausche  
Stahlkern  
MED-Zulassung

Typ: Herkules - 45m / 10mm

Typ: Herkules - 30m / 10mm



**Decent System**  
complete in box  
DIN-EN 352-3

**1892510**

Polyamid rope 12mm - 30m

**Sicherheits-Abseilset**  
komplett im Koffer  
DIN-EN 352-3

Polyamidseil 12mm - 30m



**Safety Harness**  
with shock absorber - 1,5m  
with carabiner MAS 5291  
EN 363

**1896990**

type: MAS 80-BFD - gr.0 - size:  
44-52

**1897000**

type: MAS 80-BFD - gr.1 - size:  
48-56

**Auffanggurt**  
mit Bandfalldämpfer 1,5m  
mit Karabiner MAS 5291  
EN 363

Typ: MAS 80-BFD Gr.0 - Größe:  
44-52

Typ: MAS 80-BFD - Gr.1 - Größe  
48-56





Belts / Lines  
Gurte / Leinen

**Safety Harness**

size: 48-56  
EN 363

1897010

type: MAS 80

**Auffanggurt**

Größe: 48-56  
EN 363

Typ: MAS 80



**Self Locking Lifeline-  
Retractable**

with wire rope  
as part to the personal protection  
equipment against falling.  
according to DIN-EN 360

1897020

type: MAS 51020 - length: 20 m

**Höhensicherungsgerät  
mit Drahtseil**  
als Teil zur persönlichen Schutz-  
ausrüstung gegen Absturz.  
geprüft nach DIN-EN 360

Typ: MAS 51020 - Länge: 20 m

1897022

type: MAS 51010 - length: 10 m

Typ: MAS 51010 - Länge: 10 m



**Self Locking Lifeline-  
Retractable**

4,5mm  
according to DIN-EN 360  
in plasticcase

1897021

type: MAS 51503 - length: 3 m

**Höhensicherungsgerät  
4,5mm**  
geprüft nach DIN-EN 360  
in Kunststoffgehäuse

Typ: MAS 51503 - Länge: 3 m

Belts / Lines  
Gurte / Leinen



**Safety Harness**  
with shock absorber - 1,5m  
with carabiner MAS 5291  
Size: 48-56  
EN 361 + 358 + 813

**1897095**

type: MAS 200

**Auffanggurt**  
mit Bandfalldämpfer - 1,5 m  
mit Karabiner MAS 5291  
Größe: 48-56  
EN 361 + 358 + 813

Typ: MAS 200



**Safety Harness**  
size 1  
CE EN 358 + 813

**1897096**

type: SEQUOIA SRT

**Sitz- und Haltegurt**  
Größe 1  
CE EN 358 + 813

Typ: SEQUOIA SRT



**Shock-Absorbing Lanyard**  
DIN-EN 354 + 355  
webbing sling 27mm  
and carabiner on rope end

**1897100**

type: MAS 51 - 1,5m

**Sicherungsband mit  
Bandfalldämpfer**  
DIN-EN 354 + 355  
Gurtband 27mm  
mit Haken und Karabiner  
am Seilende

Typ: MAS 51 - 1,5m



**Safety Waist Belt**  
with 2 D-rings  
without safety rope  
100-110cm abdominal girth

**1897200**

type: B 2 - 1500mm - EN 358

**1897220**

type: B 2 - 1400mm - EN 358

**1897240**

type: B 2 - 1300mm - EN 358

**Haltegurt**  
mit 2 D-Ringen  
ohne Leine  
100-110cm Bauchumfang

Typ: B 2 - 1500mm - EN 358

Typ: B 2 - 1400mm - EN 358

Typ: B 2 - 1300mm - EN 358



Belts / Lines  
Gurte / Leinen

**Shock Absorbing Lanyard**  
DIN-EN 354 + 355  
polyamide rope - 12mm  
and carabiner MAS 51  
on both rope ends

1897300

type: 1 - 1,5m

1897305

type: 1 - 2,0m

**Sicherungsseil mit  
Bandfalldämpfer**  
DIN-EN 354 + 355  
Polyamid-Seil - 12mm  
mit Karabinerhaken MAS 51  
am beiden Seilenden

Typ: 1 - 1,5m

Typ: 1 - 2,0m



**Safety Device Rope**  
carabiner MAS 51 + 65  
DIN-EN 354

1897310

polyamide rope 12mm - 1,5m

**Sicherungsseil**  
Karabinerhaken MAS 51+65  
DIN-EN 354

Polyamid-Seil - 12mm - 1,5m



**Slide Chuck**  
inclusive shock absorber  
for 16mm rope EN 353-2

1897315

type: MAS 4

**Auffanggerät**  
inklusive Bandfalldämpfer  
für Seil D=16mm - EN353-2

Typ: MAS 4

Westis + Aprons  
Westen / Schürzen



**Apron**

1382300

PVC - white - 110cm

**Schürze**

PVC - weiß - 110cm

Wests + Aprons  
*Westen / Schürzen*



**Warning Vest**

**1810800**

EN 471 - Reflective Tape - orange

**Warnweste**

EN 471 - Reflexstreifen - orange



**Warning Vest**

**1810830**

EN 471 - Reflective Tape - yellow

**Warnweste**

EN 471 - Reflexstreifen - gelb

*Schutzkleidung - Protective Clothes*



**Bag**  
for protective equipment

**1811500**

60 x 36 x 36 cm

**Tasche**  
für Schutzausrüstung

60 x 36 x 36 cm



**Heat Protective Suit**  
helmet-gloves-boots-jacket-  
trousers-bag  
MED approved

**1841000**

type: Flameguard - size: universal

**Hitzeschutzanzug**  
Hersteller: PG Products Ltd.  
Helm-Handschuhe-Stiefel-Jacke-  
Hose-Tragetasche  
MED-Zulassung

Typ: Flameguard - Grösse:  
universal



**Heat Protective Suit**  
canvas  
helmet-gloves-boots-jacket-  
trousers-bag  
MED approved

**1841010**

type: Firebuddy Plus - universal

**Hitzeschutzanzug**  
Gewebeanzug  
Helm-Handschuhe-Stiefel-Jacke-  
Hose-Tragetasche  
MED-Zulassung

Typ: Firebuddy Plus - universal



**Face cover glass**  
250 x 150 mm  
EXCALOR B-20 + Pflüger + TBI

**1841700**

for heat protective suit

**Schutzscheibe**  
250 x 150 mm  
EXCALOR B-20 + Pflüger + TBI

für Hitzeschutzanzug



**Face Cover Glass**  
220 x 150mm  
gold bedampft, curved

**1841710**

for ISOTEMP/PC

**Schutzscheibe**  
220 x 150mm  
gold bedampft - gebogen

für ISOTEMP/PC



*Schutzkleidung - Protective Clothes*



**Heat Protective Suit**

MED approval  
heavy duty in carrying bag  
Protection against flames EN531,  
convection heat EN367.  
Coat with fixed hood, replaceable  
gold steamed heat protection visor  
15x25cm. Trousers with adjustable  
elastic braces.  
The breathing apparatus to be worn  
un

**1841920**

type: Seaprotector - size L

**Hitzeschutzanzug**

MED Zulassung  
schwere Ausführung, in  
Tragetasche  
Schutz gegen kurzzeitigen  
Flammkontakt.  
Jacke mit eingearbeiteter Haube,  
auswechselbarer goldbedampfter  
Hitzeschutzscheibe 15x25cm,  
Hose mit verstellbarer elastischen  
Hosenträgern. Atemschutzgerät  
wird un

Typ: Seaprotector - Größe L



**Fire Protection Trousers**

MED approval

**1841965**

type: 1VPV - NOMEX - XL - blue

**Hitzeschutzanzug Hose**

MED Zulassung

Typ: 1VPV - NOMEX - XL - blau



**Fire Protection Jacket**

MED approval

**1841966**

type: 1VLV - NOMEX - XL - blue

**Hitzeschutzanzug Jacke**

MED Zulassung

Typ: 1VLV - NOMEX - XL - blau

*Breathing Apparatus  
Pressluftatmer*



**Breathing Face Mask**

screwing type  
normal pressure  
Dräger-No: R54990

**1826800**

type: Panorama Nova EPDM RA

**Atemmaske**

Schraub Typ  
Normaldruck  
Dräger-Nr: R54990

Typ: Panorama Nova EPDM RA



Breathing Apparatus  
Pressluftatmer

**Head Straps**  
Dräger-No: R26279

**1826810**

for fullmask Panorama Nova EPDM

**Kopfband**  
Dräger-Nr: R26279

für Vollmaske Panorama Nova EPDM



**Screening Grid**  
Dräger-No: R50833

**1826820**

for Panorama Nova EPDM

**Scheibe**  
Dräger-Nr: R50833

für Dräger Panorama Nova EPDM



**Cleaning Tissue**  
10 pieces / package  
Dräger-No: R54134

**1826830**

for breathing apparatus

**Reinigungstuch**  
10 Stück / Paket  
Dräger-Nr: R54134

für Atemmasken



**Adapter**  
for DRÄGER air bottles  
female thread: 5/8"

**1827450**

type: CF15-D

**Adapter**  
für Pressluftflaschen  
Innengewinde: 5/8"

Typ: CF15-D



**Breathing Apparatus**  
- lightweight and enhanced carrying system  
- innovative space-frame integrating the hoses  
- easy to clean and maintain service friendly design  
Dräger-No.: 3357774  
plugging type / overpressure

**1827711**

Dräger PAS Lite A - basic device

**Pressluftatmer**  
- Leichtes Tragesystem  
- Innovativer Tragerahmen mit integrierten Schläuchen  
- Einfache Reinigung und wartungsfreundliches Design  
Dräger-Nr.: 3357774  
Steck / Überdruck

Dräger PAS Lite A - Grundgerät



**Respirator for Breathing Apparatus**  
plugging type  
overpressure  
Dräger-No.: R54450

**1827740**

type: Panorama Nova Standard P

**Atemmaske**  
Steck Typ  
Überdruck  
Dräger-Nr. R54450

Typ: Panorama Nova Standard P

## Breathing Apparatus *Pressluftatmer*



### Tool Set

7 pieces in bag - consisting of:  
- seal ring lift R21402  
- screwdriver 4x100  
- screwdriver 5,5x125  
- allen key No. 6  
- forehead hole key  
- single ended spanner Nr.30  
- double ended spanner 10/13

**1827800**

for Dräger breathing apparatus

### Werkzeug - Set

7 Teile in Tasche, bestehend aus:  
- Dichtungsausheber R21402  
- Schraubendreher 4x100  
- Schraubendreher 5,5x125  
- Inbusschlüssel Nr. 6  
- Stirnlochschlüssel  
- Maulschlüssel Nr.30  
- Doppelpmaulschlüssel 10/13

für Dräger Pressluftatmer

### Air Cylinder

Dräger-Nr.: 3355002

**1827900**

6 litre / 300 bar - filled

### Pressluftflasche

Dräger-Nr.: 3355002

6 Liter / 300 bar - gefüllt



### Disinfectant

for respirators

**1828400**

750ml / bottle

### Desinfektionsmittel

für Masken

750 ml / Flasche



### Talcum Powder

**1828410**

750 gramm per can

### Talkum Puder

750 Gramm pro Dose



### Valve for Air Cylinder

**1828700**

for 6 litre / 300 bar bottles

### Pressluftflaschenventil

für 6 Liter / 300 bar Flaschen



### Wall Bracket

galvanized steel

**3811100**

for 2 air cylinder - 6 litre

### Wandhalterung

Stahl verzinkt

für 2 Pressluftflaschen - 6 Liter



### Wall Bracket

galvanized steel

**3811150**

for 1 air cylinder - 6 litre

### Wandhalterung

Stahl verzinkt

für 1 Pressluftflasche - 6 Liter





**Rescue Blanket**

**1811360**

160x210cm

***Rettungsdecke***

*160x210cm*



**AIS Survivor Recovery System**

124x47x27mm  
7 year battery lifetime

**1811365**

type: SafeLink R10

***AIS - Notfallsender***

*124x47x27mm  
Batterielebensdauer: 7 Jahre*

*Typ: SafeLink R10*



# Fire Protection

## *Feuerschutz*





Powder Extinguishers  
*Pulverlöscher*

**Powder - Fire Extinguisher**

with car bracket  
EN 3 euro standard  
MED approval  
fire class A + B + C  
function duration: 10 seconds  
spraying width: 4 meters  
without manometer

**1781500**

type: GLORIA F 2 G

**Pulver - Feuerlöscher**

mit KFZ-Halter  
EN 3 Euronorm  
MED Zulassung  
Brandklasse A + B + C  
Funktionsdauer: 10 Sekunden  
Spritzweite: 4 Meter  
ohne Manometer

Typ: GLORIA F 2 G

**1781510**

type: GLORIA P2GM

Typ: GLORIA P2GM



**Powder - Fire Extinguisher**

with wallbracket  
lable: english language  
Load extinguisher with impact  
button armature  
inside CO<sup>2</sup> cartridge  
EN 3 euro standard  
MED approval  
fire class A + B + C  
function duration: 16 seconds  
spraying width: 6 meters

**1782410**

type: GLORIA PSE 9 G

**Pulver - Feuerlöscher**

mit Wandhalter  
Englische Beschriftung  
Aufladelöscher mit  
Schlagknopfarmatur mit  
innenliegender CO<sup>2</sup> Patrone  
EN 3 Euronorm  
MED Zulassung  
Brandklasse A + B + C  
Funktionsdauer: 16 Sekunden  
Spritzweite: 6 Meter

Typ: GLORIA PSE 9 G



**Powder - Fire Extinguisher**

with wall bracket  
with manometer  
permanent pressure extinguisher  
EN 3 euro standard  
MED approval  
fire class A + B + C  
function duration: 16 seconds  
spraying width: 6 meters

**1782800**

type: GLORIA PD6GA

**Pulver - Feuerlöscher**

mit Wandhalter  
mit Manometer  
Dauerdrucklöscher  
EN 3 Euronorm  
MED Zulassung  
Brandklasse A + B + C  
Funktionsdauer: 18 Sekunden  
Spritzweite: 6 Meter

Typ: GLORIA PD6GA



**Powder - Fire Extinguisher**

without bracket  
Load extinguisher; inside CO<sup>2</sup>  
cartridge  
EN 3 euro standard; MED approval;  
fire class A + B + C  
function duration: 14 seconds;  
spraying width: 6 meters

**1782910**

type: GLORIA P6 Easy

**Pulver - Feuerlöscher**

ohne Halter  
Aufladelöscher; innenliegende CO<sup>2</sup>  
Patrone  
EN 3 Euronorm; MED Zulassung;  
Brandklasse A + B + C  
Funktionsdauer: 14 Sekunden;  
Spritzweite: 6 Meter

Typ: GLORIA P6 Easy



**Powder - Fire Extinguisher**

without bracket  
lable: english language  
load extinguisher  
with outside CO<sup>2</sup> cartridge  
EN 3 euro standard  
fire class A + B + C  
function duration: 16 seconds  
spraying width: 5 meters

**1784000**

type: GLORIA P 12 G

**Pulver - Feuerlöscher**

ohne Halter  
Englische Beschriftung  
Aufladelöscher  
ausenliegende CO<sup>2</sup> Patrone  
EN 3 Euronorm  
Brandklasse A + B + C  
Funktionsdauer: 16 Sekunden  
Spritzweite: 5 Meter

Typ: GLORIA P12 G



Powder Extinguishers

*Pulverlöscher*



**Powder - Fire Extinguisher**  
without bracket  
load extinguisher with impact button  
armature with inside CO<sup>2</sup> cartridge  
EN 3 euro standard; MED approval;  
fire class A + B + C  
function duration: 21 seconds;  
spraying width: 7 meters

**Pulver - Feuerlöscher**  
*ohne Halter*  
*Aufladelöschers mit*  
*Schlagknopfarmatur mit*  
*innenliegender CO<sup>2</sup> Patrone*  
*EN 3 Euronorm; MED Zulassung;*  
*Brandklasse A + B + C*  
*Funktionsdauer: 21 Sekunden;*  
*Spritzweite: 7 Meter*

**1784700**

type: GLORIA PEP12GA

Typ: GLORIA PEP12GA



**Powder - Fire Extinguisher**  
with 10m hose  
wheeled  
fire class A + B + C  
function duration: 50 seconds  
spraying width: 10-12 meters

**Pulver - Feuerlöscher**  
*mit 10m Schlauch*  
*fahrbar*  
*Brandklasse A + B + C*  
*Funktionsdauer: 50 Sekunden*  
*Spritzweite: 10-12 Meter*

**1786000**

type: GLORIA P50G/10

Typ: GLORIA P50G/10

Foam Extinguishers

*Schaumlöschers*



**Foam - Fire Extinguisher**  
without bracket  
lable:international language  
foam extinguisher with  
piston cartouche  
inside CO<sup>2</sup> cartridge  
EN 3 euro standard  
MED approval  
fire class A + B  
function duration: 36 seconds  
spraying width: 5 meters

**Schaum - Feuerlöscher**  
*ohne Halter*  
*Internationale Beschriftung*  
*Aufladelöschers mit*  
*Schaum-Kolbenkartusche*  
*innenliegende CO<sup>2</sup> Patrone*  
*EN 3 Euronorm*  
*MED Zulassung*  
*Brandklasse A + B*  
*Funktionsdauer: 36 Sekunden*  
*Spritzweite: 5 Meter*

**1781350**

type: GLORIA SK9 Pro

Typ: GLORIA - SK9 Pro



**Foam - Fire Extinguisher**  
with wall bracket  
lable: german language  
foam extinguisher with piston  
cartouche  
inside CO<sup>2</sup> cartridge  
EN 3 euro standard  
fire class A + B  
function duration: 26 seconds  
spraying width: 5 meters

**Schaum - Feuerlöscher**  
*mit Wandhalter*  
*Deutsche Beschriftung*  
*Aufladelöschers mit Schaum-*  
*Kolbenkartusche*  
*innenliegende CO<sup>2</sup> Patrone*  
*EN 3 Euronorm*  
*Brandklasse A + B*  
*Funktionsdauer: 26 Sekunden*  
*Spritzweite: 5 Meter*

**1781430**

type: GLORIA SK6 Easy

Typ: GLORIA - SK6 Easy

Foam Extinguishers

Schaumlöcher



**Foam - Fire Extinguisher**  
wheeled  
GL approved  
capacity: 45 litres  
extinguishing agent: water + AFFF  
foam  
propellant agent: CO<sub>2</sub>  
dimensions (mm): Ø 390 x 980  
recipient: stainless steel  
weight: 85kg  
temperature range: +5°C / +60°C

**1781450**

type: ORFEO - PSM-45-FOAM

**Schaum - Feuerlöcher**

fahrbar  
GL Zulassung  
Kapazität: 45 Liter  
Löschmittel: Wasser + AFFF  
Schaum  
Dimension (mm): Ø 390 x 980  
Körper: Edelstahl  
Gewicht: 85kg  
Temperaturbereich: +5°C / +60°C

Typ: ORFEO - PSM-45-FOAM



**Foam - Fire Extinguisher**  
wheeled  
GL approved  
capacity: 136 litres  
extinguishing agent: water+AFFF  
foam  
propellant agent: CO<sub>2</sub>  
dimensions (mm): Ø 400 x 1450  
recipient: stainless steel  
weight: 197kg.  
temperature range: +5°C / +60°C

**1781470**

type: ORFEO - PSM-136-FOAM

**Schaum - Feuerlöcher**

fahrbar  
GL Zulassung  
Kapazität: 136 Liter  
Löschmittel: Wasser+AFFF  
Schaum  
Dimension: (mm): Ø 400 x 1450  
Körper: Edelstahl  
Gewicht: 197kg  
Temperaturbereich: +5°C / +60°C

Typ: ORFEO - PSM-136-FOAM



**Foam - Fire Extinguisher**  
wheeled  
RINA approved  
permanent pressure  
capacity: 50 litres  
extinguishing agent: water + AFFF  
foam  
dimensions (mm): Ø 315 x 1120  
recipient: stainless steel  
weight: 80kg  
temperature range: +5°C / +60°C

**1781480**

type: GLORIA SD50

**Schaum - Feuerlöcher**

fahrbar  
Dauerdruck  
RINA Zulassung  
Kapazität: 50 Liter  
Löschmittel: Wasser + AFFF  
Schaum  
Dimension (mm): Ø 315 x 1120  
Körper: Edelstahl  
Gewicht: 80kg  
Temperaturbereich: +5°C / +60°C

Typ: GLORIA - SD50



**Foam - Fire Extinguisher**  
wheeled  
RINA approved  
capacity: 135 litres  
extinguishing agent: water + AFFF  
foam  
dimensions (mm): Ø 450 x 1440  
recipient: stainless steel  
weight: 230kg  
temperature range: +0°C / +60°C

**1781481**

type: GLORIA - SA 135

**Schaum - Feuerlöcher**

fahrbar  
RINA Zulassung  
Kapazität: 135 Liter  
Löschmittel: Wasser + AFFF  
Schaum  
Dimension (mm): Ø 450 x 1140  
Körper: Edelstahl  
Gewicht: 230kg  
Temperaturbereich: +0°C / +60°C

Typ: GLORIA - SA 135

Foam Extinguishers  
*Schaumlöscher*



**Foam - Fire Extinguisher**  
5m hose - wheeled  
MED approved  
permanent pressure  
capacity: 50 litres  
extinguishing agent: water + AFFF  
foam  
dimensions (mm): Ø 315 x 1120  
recipient: stainless steel  
weight: 80kg  
temperature range: +5°C / +60°C

**1781482**

type: GLORIA SEF50/5

**Schaum - Feuerlöscher**  
5m Schlauch - fahrbar  
Dauerdruck  
MED Zulassung  
Kapazität: 50 Liter  
Löschmittel: Wasser + AFFF  
Schaum  
Dimension (mm): Ø 315 x 1120  
Körper: Edelstahl  
Gewicht: 80kg  
Temperaturbereich: +5°C / +60°C

Typ: GLORIA - SEF50/5



**Fat Burning Fire Extinguisher**  
with wall bracket  
label: german language  
MED approval  
foam extinguisher with inside CO<sup>2</sup>  
cartridge  
DIN 14406-5  
fire class A + B + F  
function duration: 30 seconds  
spraying width: 4 meters

**1781700**

type: GLORIA WI 6 FC

**Fettbrand - Feuerlöscher**  
mit Wandhalter  
Deutsche Beschriftung  
MED Zulassung  
Aufladelöscher mit innenliegender  
CO<sup>2</sup> Patrone  
DIN 14406-5; Brandklasse A + B +  
F  
Funktionsdauer: 30 Sekunden  
Spritzweite: 4 Meter

Typ: GLORIA WI 6 FC

CO<sup>2</sup> Extinguishers  
*CO<sup>2</sup> Löscher*



**CO<sup>2</sup> - Fire Extinguisher**  
with bracket  
EN 3 euro standard  
MED approval  
fire class: B  
function duration: 8,5 seconds  
spraying width: 3 meters

**1788000**

type: GLORIA KS 2 SBS

**CO<sup>2</sup> - Feuerlöscher**  
mit Halter  
EN 3 Euronorm  
MED Zulassung  
Brandklasse: B  
Funktionsdauer: 8,5 Sekunden  
Spritzweite: 3 Meter

Typ: GLORIA KS 2 SBS



**CO<sup>2</sup> - Fire Extinguisher**  
without bracket  
EN 3 euro standard  
MED approval  
fire class: B  
function duration: 13,5 seconds  
spraying width: 4-5 meters

**1788490**

type: GLORIA KS 5 SE

**CO<sup>2</sup> - Feuerlöscher**  
ohne Halter  
EN 3 Euronorm  
MED Zulassung  
Brandklasse: B  
Funktionsdauer: 13,5 Sekunden  
Spritzweite: 4-5 Meter

Typ: GLORIA KS 5 SE



Water Extinguishers  
Wasserlöscher

**Water - Fire Extinguisher**

with wall bracket  
EN 3 euro standard  
MED approval  
fire class: A  
function duration: 45 seconds  
spraying width: 7 meters

**1785400**

type: GLORIA WI 9 EN

**Wasser - Feuerlöscher**

mit Wandhalter  
EN 3 Euronorm  
MED Zulassung  
Brandklasse: A  
Funktionsdauer: 45 Sekunden  
Spritzweite: 7 Meter

Typ: GLORIA - WI 9 EN



**Water - Fire Extinguisher**

with wall bracket  
EN 3 euro standard  
MED approval  
fire class: A  
function duration: 62 seconds  
spraying width: 5 meters

**1785415**

type: GLORIA WI 6 ENI

**Wasser - Feuerlöscher**

mit Wandhalter  
EN 3 Euronorm  
MED Zulassung  
Brandklasse: A  
Funktionsdauer: 62 Sekunden  
Spritzweite: 5 Meter

Typ: GLORIA - WI 6 ENI

Zubehör Löscher - Accessories Extinguisher



**Strap**  
adjustable

**1781000**

for fire extinguisher - 85cm

**Haltegurt**  
verstellbar

für Feuerlöscher - 85cm



**Marine Bracket**  
with double strap

**1782450**

for fire extinguisher - 12kg

**Schiffshalter**  
mit Doppel-Spannband

für Feuerlöscher 12kg



**Marine Bracket**

**1782460**

for CO<sup>2</sup> - fire extinguisher - 2kg

**Schiffshalter**

für CO<sup>2</sup> - Feuerlöscher - 2kg



**Marine Bracket**

**1782490**

for type: GLORIA P6 Easy

**Schiffshalter**

für Typ: GLORIA P6 Easy

*Zubehör Löscher - Accessories Extinguisher*



**Marine bracket**  
5 / 6 / 9kg

**1782500**

type: GLORIA PS/PSE/PI/PSP/PD/  
KS

**Schiffshalter**  
5 / 6 / 9kg

Typ: GLORIA PS/PSE/PI/PSP/PD/  
KS



**Marine Bracket**

**1782510**

for type: GLORIA PEP12, Si9, Wi9

**Schiffshalter**

für Typ: GLORIA PEP12, Si9, Wi9



**Wall Bracket**

**1782600**

for type: GLORIA 6 / 12kg

**Wandhalter**

für Typ: GLORIA 6 / 12kg



**Marine Bracket**  
with double strap

**1782700**

for fire extinguisher - 6kg

**Schiffshalter**  
mit Doppel-Spannband

für Feuerlöscher 6kg





**Rimbox**  
68 x 32 x 26cm  
black with red lid  
plastic

**1784350**

for 6 / 9kg fire extinguisher

**1784370**

for 12kg / 5kg CO<sup>2</sup> fire extinguisher

**Rimbox**  
68 x 32 x 26cm  
schwarz mit rotem Deckel  
Kunststoff

für 6 / 9kg Feuerlöscher

für 12kg / 5kg CO<sup>2</sup> Feuerlöscher



**Cover**  
plastic with elastic strip

**1789100**

with symbol for extinguisher 6kg

**Schutzhaube**  
Kunststoff mit Gummizug

und Symbolzeichen für 6kg  
Feuerlöscher



**Cover for Extinguisher**  
plexiglass

**1789200**

type: GLORIA FSH-6/EK

**Schutzhaube**  
Plexiglas

Typ: GLORIA FSH-6/EK

### Reservefüllungen



**Dry Fire Extinguisher  
Powder**  
only for GLORIA fire extinguisher

**1783600**

ABC - 6kg - ADEX

**Löschpulver**  
nur für GLORIA Feuerlöscher

ABC - 6kg - ADEX

*Reservefüllungen*



**Dry Fire Extinguisher Powder**

**1783610**

ABC - 6kg - GLUTEX

**Löschpulver**

ABC - 6kg - GLUTEX



**Dry fire extinguisher powder - PL 17/87**  
only for GLORIA fire extinguisher

**1787400**

ABC - 25 kg - ADEX

**Löschpulver - PL 17/87**  
nur für GLORIA Feuerlöscher

ABC - 25kg - ADEX

*Ersatzteile*



**CO<sup>2</sup> - Pressure Cartridge**  
für type: GLORIA PS/PN/PEP 6kg

**1783500**

for powder fire extinguisher

**CO<sup>2</sup> - Druckgaspatrone**  
für Typ: GLORIA PS/PN/PEP 6kg

für Pulver Feuerlöscher



**Nitrogen - Pressure Cartridge**

**1787000**

for type GLORIA P 50 - 3 litre

**Druckgasflasche-Stickstoff**

für Typ GLORIA P50 - 3 Liter



**Hose**  
with pistol

**3903200**

for type: GLORIA - PS6

**Schlauch**  
mit Löschpistole

für Typ: GLORIA - PS6



**High Pressure Hose**  
without nozzle

**3904001**

for type: GLORIA P50 - 10m

**3904002**

for type: GLORIA P50 - 5m

**Hochdruckschlauch**  
ohne Löschpistole

Typ: GLORIA P50 - 10m

Typ: GLORIA P50 - 5m



Branch Pipes brass  
*Strahlrohre Messing*

**Multi-Purpose Branch Pipe**  
with Storz C- coupling - brass  
with additional water curtain  
without coupling  
flow rate: 365 l/min.  
spray distance - full jet: 27 m  
spray distance - spray jet: 11 m  
spray angle - man protection: 170°

**1881300**

type: CMM - 12mm - brass

**Mehrzweckstrahlrohr**  
mit Storz C-Kupplung - Messing  
mit Mannschutzbrause  
Wasserdurchfluss: 365 l/min.  
Wurfweite - Vollstrahl: 27 m  
Wurfweite - Sprühstrahl: 11 m  
Sprühwinkel-Mannschutz: 170°

Typ: CMM - 12mm - Messing



**Multi-Purpose Branch Pipe**  
with storz c coupling - brass  
flow rate: 215 l/min.  
spray distance - full jet: 27 m  
spray distance - spray jet: 11 m  
spray angle: 15°

**1881580**

type: CM - 12mm - plastic

**Mehrzweckstrahlrohr**  
mit Storz C-Kupplung - Messing  
Wasserdurchfluss: 215 l/min.  
Wurfweite - Vollstrahl: 27 m  
Wurfweite - Sprühstrahl: 11 m  
Sprühwinkel: 15°

Typ: CM - 12mm - Kunststoff

Branch Pipes Alloy  
*Strahlrohre Alu*



**Multi-Purpose Branch Pipe**  
with additional water curtain  
with storz c coupling  
flow rate: 410 l/min.  
spray distance - full jet: 32 m  
spray distance - spray jet: 15 m  
spray angle - man protection: 170°

**1881480**

type: CMM - 19mm - alloy

**Mehrzweckstrahlrohr**  
mit Mannschutzbrause  
mit Storz C - Kupplung  
Wasserdurchfluss: 410 l/min.  
Wurfweite - Vollstrahl: 32 m  
Wurfweite - Sprühstrahl: 15 m  
Sprühwinkel-Mannschutz: 170°

Typ: CMM - 19mm - Aluminium



**Multi-Purpose Branch Pipe**  
with storz c coupling - aluminium  
flow rate: 215 l/min.  
spray distance - full jet: 27 m  
spray distance - spray jet: 11 m  
spray angle: 15°

**1881600**

type: CM - 12 mm - plastic

**Mehrzweckstrahlrohr**  
mit Storz C-Kupplung - Aluminium  
Wasserdurchfluss: 215 l/min.  
Wurfweite - Vollstrahl: 27 m  
Wurfweite - Sprühstrahl: 11 m  
Sprühwinkel: 15°

Typ: CM - 12 mm - Kunststoff



**Multi-Purpose Branch Pipe**  
with additional water curtain  
with storz c coupling  
flow rate: 365 l/min.  
spray distance - full jet: 27 m  
spray distance - spray jet: 11 m  
spray angle - man protection: 170°

**1881700**

type: CMM - 12mm - aluminium

**Mehrzweckstrahlrohr**  
mit Mannschutzbrause  
mit Storz C - Kupplung  
Wasserdurchfluss: 365 l/min.  
Wurfweite - Vollstrahl: 27m  
Wurfweite - Sprühstrahl: 11m  
Sprühwinkel-Mannschutz: 170°

Typ: CMM - 12mm - Aluminium

Branch Pipes HS  
*Strahlrohr HS - ohne Kupplung*



**Branch Pipe**  
without coupling  
MED approval

**Strahlrohr**  
ohne Kupplung  
MED - Zulassung

**1881710**

type: HS - 20mm - 2" male thread

Typ: HS - 20mm - mit 2  
" Außengewinde

**1881740**

type: HS - 12mm - 2" male thread

Typ: HS - 12mm - mit 2  
" Außengewinde

**1881900**

type: HS - 16mm - 2" male thread

Typ: HS - 16mm - mit 2  
" Außengewinde

Accessories Branch Pipes  
*Zubehör Strahlrohre*



**Bracket**  
galvanized steel

**Halter**  
Stahl verzinkt

**1883000**

for branch pipe - 42-55mm

für Strahlrohr - 42-55mm



Storz  
Storz

**Suction Hose Coupling**  
brass - long shaft

**Saugkupplung**  
Messing - langer Stutzen

**1527900**

type: Storz C-52 - for hose: 38mm

Typ: Storz C-52 - für Schlauch: 38 mm

**1880100**

type: Storz C52 - for hose: 52mm

Typ: Storz C-52 - für Schlauch: 52mm

**1880120**

type: Storz B-75 - for hose: 75mm

Typ: Storz B-75 - für Schlauch: 75mm

**1880130**

type: Storz 65 - for hose: 65mm

Typ: Storz 65 - für Schlauch: 65mm

**1880140**

type: Storz D-25 - for hose: 25mm

Typ: Storz D-25 - für Schlauch: 25mm



**Suction Hose Coupling**  
aluminium - long shaft

**Saugkupplung**  
Aluminium - langer Stutzen

**1880160**

type: Storz B-75 - for hose: 75mm

Typ: Storz B-75 - für Schlauch: 75mm

**1880170**

type: Storz 65 - for hose: 65mm

Typ: Storz 65 - für Schlauch: 65 mm

**1880180**

type: Storz D-25 - for hose: 25mm

Typ: Storz D-25 - für Schlauch: 25mm

**1880200**

type: Storz C52 - for hose: 52mm

Typ: Storz C-52 - für Schlauch: 52mm

**1880400**

type: Storz C52 - for hose: 38mm

Typ: Storz C-52 - für Schlauch: 38mm



**Reducer**  
aluminium

**Übergangsstück**  
Aluminium

**1880190**

type: Storz D-25/C-52

Typ: Storz D-25/C-52



Storz

Storz



**Adapter**  
brass

**1880250**

type: Storz 65 - 2" female thread

**1881980**

type: Storz 38 - 2" female thread

**1881990**

type: Storz D-25 - 1" female thread

**1882000**

type: Storz C-52 - 2" female thread

**1882005**

type: Storz C-52 - 2,5" female thread

**1882060**

type: Storz B-75 - 2" female thread

**1882080**

type: Storz B-75 - 3" female thread

**Festkupplung**  
Messing

Typ: Storz 65 - 2" Innengewinde

Typ: Storz 38 - 2" Innengewinde

Typ: Storz D-25 - 1" Innengewinde

Typ: Storz C-52 - 2" Innengewinde

Typ: Storz C-52 - 2,5" Innengewinde

Typ: Storz B-75 - 2" Innengewinde

Typ: Storz B-75 - 3" Innengewinde



**Adapter**  
aluminium

**1880260**

type: Storz 65 - 2" female thread

**1882010**

type: Storz D-25 - 1" female thread

**1882050**

type: Storz C-52 - 2" female thread

**1882070**

type: Storz B-75 - 3" female thread

**Festkupplung**  
Aluminium

Typ: Storz 65 - 2" Innengewinde

Typ: Storz D-25 - 1" Innengewinde

Typ: Storz C-52 - 2" Innengewinde

Typ: Storz B-75 - 3" Innengewinde



**Pressure Hose Coupling**  
brass - short shaft

**1882220**

type: Storz C-52 - for hose: 52mm

**Druckkupplung**  
Messing - kurzer Stutzen

Typ: Storz C-52 - Schlauch: 52mm



**Pressure Hose Coupling**  
aluminium - short shaft

**1882250**

type: Storz B-75 - for hose: 75mm

**1882270**

type: Storz C-52 - for hose: 52mm

**1882280**

type: Storz 38 - for hose: 38mm

**Druckkupplung**  
Aluminium - kurzer Stutzen

Typ: Storz B-75 - Schlauch: 75mm

Typ: Storz C-52 - Schlauch: 52mm

Typ: Storz 38 - für Schlauch: 38mm



Storz  
Storz

**Blank Cap**  
with chain

**1882300**

type: Storz C-52 - brass

**1882310**

type: Storz 38 - brass

**1882320**

type: Storz D-25 - brass

**1882330**

type: Storz B-75 - brass

**1882410**

type: Storz 65 - brass

**Blank Cap**  
with chain

**1882370**

type: Storz B-75 - aluminium

**1882380**

type: Storz D-25 - aluminium

**1882390**

type: Storz 38 - aluminium

**1882400**

type: Storz C-52 - aluminium

**1882420**

type: Storz 65 - aluminium

**Blindkupplung**  
mit Kette

Typ: Storz C-52 - Messing

Typ: Storz 38 - Messing

Typ: Storz D-25 - Messing

Typ: Storz B-75 - Messing

Typ: Storz 65 - Messing

**Blindkupplung**  
mit Kette

Typ: Storz B-75 - Aluminium

Typ: Storz D-25 - Aluminium

Typ: Storz 38 - Aluminium

Typ: Storz C-52 - Aluminium

Typ: Storz 65 - Aluminium

Nakajima  
Nakajima

**Hose Coupling**  
brass

**1880320**

type: Nakajima DN 50 - for hose:  
52mm

**1880330**

type: Nakajima DN 65 - for hose:  
64mm

**1880340**

type: Nakajima DN 65 - for hose:  
52mm

**1880500**

type: Nakajima DN 65 - for hose:  
38mm

**1880540**

type: Nakajima DN 40 - for hose:  
38mm

**Schlauchkupplung**  
Messing

Typ: Nakajima DN 50 - für  
Schlauch: 52mm

Typ: Nakajima DN 65 - für  
Schlauch: 64mm

Typ: Nakajima DN 65 - für  
Schlauch: 52mm

Typ: Nakajima DN 65 - für  
Schlauch: 38mm

Typ: Nakajima DN 40 - für  
Schlauch: 38mm

Nakajima  
Nakajima



**Adapter**  
brass

**1880350**

type: Nakajima DN 65 - 2" female thread

**Festkupplung**  
Messing

Typ: Nakajima DN 65 - 2" Innengewinde

**1880390**

type: Nakajima DN 40 - 2" female thread

Typ: Nakajima DN 40 - 2" Innengewinde

**1880420**

type: Nakajima DN 65 - 2,5" female thread

Typ: Nakajima DN 65 - 2,5" Innengewinde



**Adapter**  
brass

**1880360**

type: Nakajima DN 50 - 2" female thread

**Festkupplung**  
Messing

Typ: Nakajima DN 50 - 2" Innengewinde



**Blank - Cap**  
with chain

**1882430**

type: Nakajima DN 50 - brass

**Blindkupplung**  
mit Kette

Typ: Nakajima DN 50 - Messing

**1882440**

type: Nakajima DN 65 - brass

Typ: Nakajima DN 65 - Messing

**1882450**

type: Nakajima DN 40 - brass

Typ: Nakajima DN 40 - Messing

ANSI  
ANSI



**Hose Coupling**  
brass

**1880210**

type: ANSI 2" - for hose 52mm

**Schlauchkupplung**  
Messing

Typ: ANSI 2" - für Schlauch: 52mm

**1880560**

type: ANSI 2,5" - for hose 65mm

Typ: ANSI 2,5" - für Schlauch: 65mm



**Adapter**  
brass

**1880220**

type: ANSI 2"

**Festkupplung**  
Messing

Typ: ANSI 2"

Nunan  
Nunan



**Adapter**  
brass

**1880570**

type: Nunan 2,5" - 2" female thread

**Festkupplung**  
Messing

Typ: Nunan 2,5" - 2" Innengewinde



Nunan  
Nunan

**Hose Coupling**  
brass

**1880580**

type: Nunan 2,5" - for hose: 64mm

**Schlauchkupplung**  
Messing

Typ: Nunan 2,5" - für Schlauch:  
64mm



NOR  
NOR

**Adapter**  
brass

**1880480**

type: NOR DN 65 - 2" female thread

**Festkupplung**  
Messing

Typ: NOR DN 65 - 2" Innengewinde

**1880490**

type: NOR DN 50 - 2" female thread

Typ: NOR DN 50 - 2" Innengewinde



**Hose Coupling**  
brass

**1880510**

type: NOR DN 65 - for hose: 52mm

**Schlauchkupplung**  
Messing

Typ: NOR DN 65 - für Schlauch:  
52mm

other Couplings  
sonstige Kupplungen



**Adapter**  
brass

**1880520**

type: Rotta DN 70 - 2" female thread

**Festkupplung**  
Messing

Typ: Rotta DN 70 - 2" Innengewinde



**Adapter**  
brass

**1880530**

type: Guillemin DN 40 - 2" female  
thread

**Festkupplung**  
Messing

Typ: Guillemin DN 40 - 2  
" Innengewinde



**Hose Coupling**  
brass

**1880531**

type: Guillemin DN 40 - for hose:  
50mm

**Schlauchkupplung**  
Messing

Typ: Guillemin DN 40 - für  
Schlauch: 50mm

Landing valves  
Decksventile



**Landing Valve**  
without coupling  
inlet: flange PN 16  
outlet: 2" male thread  
outside diameter: 164 mm  
gunmetal

**1880290**

straight - DN 50 - DIN 86211

**Decksventil**  
ohne Kupplung  
Eingang: Flansch PN 16  
Ausgang: 2" Außengewinde  
Außendurchmesser: 164 mm  
Rotguss

Gerade - DN 50 - DIN 86211



**Landing Valve**  
without coupling  
inlet: flange PN 16  
outlet: 2" male thread  
outside diameter: 164 mm  
gunmetal

**1880300**

angle form - DN 50 - DIN 86211

**Decksventil**  
ohne Kupplung  
Eingang: Flansch PN 16  
Ausgang: 2" Außengewinde  
Außendurchmesser: 164 mm  
Rotguss

Eckform - DN 50 - DIN 86211



**Handwheel**  
140 x 12mm - DIN 390 B

**1880310**

for landing valve

**Handrad**  
140 x 12mm - DIN 390 B

für Decksventil



**International Shore Connection**  
without coupling  
brass

**1885600**

RG 2" - DN 50mm

**Internationaler Landanschluss**  
ohne Kupplung  
Messing

RG 2" - DN 50mm

Sealings  
Dichtungen Kupplungen



**Coupling Sealing Ring**  
65 x 50 x 3mm

**1880240**

type: ANSI 2"

**Kupplungsdichtring**  
65 x 50 x 3mm

Typ: ANSI 2"



**Coupling Sealing Ring**

**1880370**

type: Nakajima DN 65

**1880380**

type: Nakajima DN 50

**Kupplungsdichtring**

Typ: Nakajima DN 65

Typ: Nakajima DN 50



Sealings  
Dichtungen Kupplungen

**Coupling Sealing Ring**  
60 x 47 x 10mm

**1885000**

type: Storz C

**Kupplungsdichtring**  
60 x 47 x 10mm

Typ: Storz C



**Coupling Sealing Ring**

**1885050**

type: Storz B

**Kupplungsdichtring**

Typ: Storz B



**Coupling Sealing Ring**

**1885100**

type: Storz 65

**Kupplungsdichtring**

Typ: Storz 65

Accessories Couplings  
Zubehör Kupplungen



**Binding Wire**  
brass - 10m per roll  
diameter: 1,5mm

**1527910**

for hose couplings

**Einbindedraht**  
Messing - 10m pro Rolle  
Durchmesser: 1,5mm

für Schlauchkupplung



**Binding wire**  
aluminium - 10m per roll  
diameter: 1,5 mm

**1527920**

for hose couplings

**Einbindedraht**  
Aluminium - 10m pro Rolle  
Durchmesser: 1,5 mm

für Schlauchkupplung



**Hose Binding Device**  
hand operated

**1527950**

with turnbuckle

**Einbindeapparat**  
Handbetrieb

inklusive Spannvorrichtung



**Chain for Blanc Cap**  
galvanized steel

**1882100**

with s-hook - 28cm

**Kette für Blindkupplung**  
Stahl verzinkt

mit S-Haken - 28cm



Accessories Couplings  
Zubehör Kupplungen



**Chain for Blanc Cap**  
brass

**1882600**

with s-hook - 31cm

**Kette für Blindkupplung**  
Messing

mit S-Haken - 31cm



**Coupling Spanner**

**1885300**

type: BC

**Kupplungsschlüssel**

Typ: BC



**Coupling Spanner**

**1885320**

type: BC - with frost protection

**Kupplungsschlüssel**

Typ: BC - mit Kälteschutz



**Coupling Spanner**

**1885340**

type: ABC

**Kupplungsschlüssel**

Typ: ABC



**Coupling Spanner**

**1885350**

type: Nakajima JB-40

**1885360**

type: Nakajima JB-50

**1885370**

type: Nakajima JB-65

**Kupplungsschlüssel**

Typ: Nakajima JB-40

Typ: Nakajima JB-50

Typ: Nakajima JB-65



Hoses - without  
*Schläuche ohne Kupplung*

**Fire Hose**  
without couplings  
MED approved  
colour: white

**Feuerlöschschlauch**  
ohne Kupplungen  
MED - Zugelassen  
Farbe: weiß

**1870050**

type: 38 mm - length: 15 m

Typ: 38 mm - Länge: 15 m

**1870070**

type: 38 mm - length: 20 m

Typ: 38 mm - Länge: 20 m

**1870100**

type: C-52 mm - length: 15 m

Typ: C-52 mm - Länge: 15 m

**1870110**

type: C-52 mm - length: 18 m

Typ: C-52 mm - Länge: 18 m

**1870380**

type: C-52 mm - length: 10 m

Typ: C-52 mm - Länge: 10 m

**1870650**

type: 65 mm - length: 15 m

Typ: 65 mm - Länge: 15 m

**1870651**

type: 65 mm - length: 25 m

Typ: 65 mm - Länge: 25 m

**1870700**

type: 65 mm - length: 20 m

Typ: 65 mm - Länge: 20 m

**1870800**

type: B-75 mm - length: 20 m

Typ: B-75 mm - Länge: 20 m

**1870810**

type: B-75 mm - length: 25 m

Typ: B-75 mm - Länge: 25 m

**1871000**

type: C-52 mm - length: 20 m

Typ: C-52 mm - Länge: 20 m

**1871280**

type: C-52 mm - length: 25 m

Typ: C-52 mm - Länge: 25 m

**1871290**

type: C-52 mm - length: 30 m

Typ: C-52 mm - Länge: 30 m

Hoses - brass  
*Schläuche Messingkupplungen*



**Fire Hose**  
with brass couplings  
MED approved  
colour: red

**Feuerlöschschlauch**  
mit Messing Kupplungen  
MED - Zugelassen  
Farbe: rot

**1870180**

type: C-52 mm - length: 15 m

Typ: C-52 mm - Länge: 15 m

**1870420**

type: C-52 mm - length: 10 m

Typ: C-52 mm - Länge: 10 m

**1870656**

type: 65 mm - length: 18 m

Typ: 65 mm - Länge: 18 m

**1871390**

type: C-52 mm - length: 25 m

Typ: C-52 mm - Länge: 25 m

Hoses - brass  
*Schläuche Messingkupplungen*



**Fire Hose**  
with brass couplings  
MED approved  
colour: white

**Feuerlöschschlauch**  
mit Messing Kupplungen  
MED - Zugelassen  
Farbe: weiß

**1870200**

type: C-52 mm - length: 15 m

Typ: C-52 mm - Länge: 15 m

**1870390**

type: C-52 mm - length: 10 m

Typ: C-52 mm - Länge: 10 m

**1870430**

type: C-52 mm - length: 18 m

Typ: C-52 mm - Länge: 18 m

**1870652**

type: 65 mm - length: 25 m

Typ: 65 mm - Länge: 25 m

**1870661**

type: 65 mm - length: 15 m

Typ: 65 mm - Länge: 15 m

**1871100**

type: C-52 mm - length: 20 m

Typ: C-52 mm - Länge: 20 m

**1871350**

type: C-52 mm - length: 25 m

Typ: C-52 mm - Länge: 25 m

Hoses - alloy  
*Schläuche Aluminiumkupplungen*



**Fire Hose**  
with Storz-C aluminium couplings  
MED approved  
colour: red

**Feuerlöschschlauch**  
mit Storz-C Aluminium Kupplungen  
MED - Zugelassen  
Farbe: rot

**1870170**

type: C-52 mm - length: 15 m

Typ: C-52 mm - Länge: 15 m

**1870410**

type: C-52 mm - length: 10 m

Typ: C-52 mm - Länge: 10 m



Hoses - alloy  
Schläuche Aluminiumkupplungen

**Fire Hose**  
with aluminium couplings  
MED approved  
colour: white

**Feuerlöschschlauch**  
mit Aluminium Kupplungen  
MED - Zugelassen  
Farbe: weiß

**1870300**

type: C-52 mm - length: 15 m

Typ: C-52 mm - Länge: 15 m

**1870370**

type: C-52 mm - length: 5 m

Typ: C-52 mm - Länge: 5 m

**1870400**

type: C-52 mm - length: 10 m

Typ: C-52 mm - Länge: 10 m

**1870660**

type: 65 mm - length: 15 m

Typ: 65 mm - Länge: 15 m

**1870670**

type: 38 mm - length: 15 m

Typ: 38 mm - Länge: 15 m

**1870680**

type: 38 mm - length: 20 m

Typ: 38 mm - Länge: 20 m

**1870690**

type: 38 mm - length: 30 m

Typ: 38 mm - Länge: 30 m

**1870740**

type: 65 mm - length: 20 m

Typ: 65 mm - Länge: 20 m

**1871200**

type: C-52 mm - length: 20 m

Typ: C-52 mm - Länge: 20 m

**1871300**

type: C-52 mm - length: 25 m

Typ: C-52 mm - Länge: 25 m

Accessories Hoses  
Zubehör Schläuche



**Fire Hose Reel**  
diameter: 480 mm  
for 30m C-hose  
steel - red coated

**Schlauchhaspel**  
Durchmesser: 480 mm  
für 30m C-Schlauch  
Stahl - rot gepulvert

**1885400**

with swivel arm

mit Wandarm - schwenkbar



**Wall Bracket**  
steel - red - coated

**Wandanker**  
Stahl - rot - gepulvert

**1885500**

for hose reel

für Schlauchhaspel

Accessories Hoses  
Zubehör Schläuche



**Fire Hose Box**  
galvanized steel - red

**1894000**

64 x 74 x 14cm

**Schlauchkasten**  
Stahl verzinkt - rot

64 x 74 x 14cm



**Fire Hose Box**  
GRP - red

**1894150**

dia: 60 x 24cm

**Schlauchkasten**  
GFK - rot

Durchmesser: 60 x 24cm



**Fire Hose Bin**  
steel coated

**3854000**

width: 140mm - red

**Schlauchtasche**  
Stahl verzinkt - Pulverbeschichtet

Breite: 140mm - rot



**Fire Hose Box**  
shock resistant - red coated  
RAL 3000

**3856000**

482 x 570 x 180mm - steel 5mm

**Schlauchkasten**  
Seeschlagfest - rot lackiert  
RAL 3000

482 x 570 x 180mm - 5mm Stahl



### EEBD

#### Emergency Escape Breathing Device

without bracket  
MED approval  
oxygen cylinder  
maintenance free for 15 years  
packed in orange stowage container  
dimensions: l 210 x w 230 x h 100mm

**1827290**

type: Ocenco M20.2

#### Fluchttretter

ohne Halter  
MED Zulassung  
Sauerstoffpatrone  
wartungsfrei für 15 Jahre  
verpackt in orangefarbener Box  
Abmessungen: L 210 x B 230 x H 100mm

Typ: Ocenco M20.2



#### Emergency Escape Breathing Device

duration: 15 minutes  
LR/GL/SBG  
MED approval  
3 litre / 200 bar compressed air cylinder  
audible low content warning  
carrying bag: fluorescent orange  
Dimensions: 490 x 160 x 250 mm  
Däger-No.: R45002

**1827350**

type: Dräger Saver CF 15

#### Fluchttretter

Einsatzdauer: 15 Minuten  
LR/GL/SBG  
MED Zulassung  
3 Liter / 200 bar Druckluftflasche  
akustische Restdruckwarnung  
Tragetasche: singalfarben orange  
Abmessung: L 490 x B 160 x H 250 mm  
Däger-Nr.: R45002

Typ: Dräger Saver CF 15

### Filter Devices

#### Filter Fluchtgeräte



#### Fire Escape Hood

combination cartridge CO-P2  
provides protection against smoke, gases and particles,  
duration: minimum of 15 minutes  
total shelf life: 12 years  
filterexchange: every 6 years  
dimensions: 8 x 19 x 13,5 cm  
approval CE mark, tested to EN 403

**1827410**

type: Dräger - PARAT C

#### Brandfluchthaube

Kombinationsfilter CO-P2 gegen Brandgase, Rauche und Partikel  
Gebrauchsdauer: mindestens 15 Minuten  
Service: 6 Jahre wartungsfrei  
Filterwechsel nach 6 Jahren  
Gesamtlebenszeit 12 Jahre  
Abmessungen: 8 x 19 x 13,5 cm  
CE Zeichen  
geprüft nach EN 403  
Dräger-Nr

Typ: Dräger - PARAT C



#### Filter Escape Device

Gasfilter against organic and anorganic gases and vapours  
ABEK 15 in accordance to DIN 58647 part 7  
duration: 15 minutes  
shelf life 4 years free of service  
filterexchange: every 4 years  
total shelf life: 12 years  
dimensions: 170 x 110 x 90mm

**1827440**

type: PARAT 3100

#### FluchtfILTERgerät

Gasfilter gegen organische und anorganische Gase und Dämpfe  
ABEK 15 nach DIN 58647 Teil 7  
Gebrauchsdauer: 15 Minuten  
Lagerzeit: 4 Jahre wartungsfrei  
Filterwechsel: alle 4 Jahre  
Gesamtlebenszeit: 12 Jahre  
Abmessungen: 170 x 110 x 90mm

Typ: DRÄGER - PARAT 3100



Accessories Escape Devices  
*Zubehör Fluchtgeräte*



**Seal**  
10 pieces per package  
plastic

**1860050**

for EEBD

**Plombe**  
10 Stück pro Paket  
Kunststoff

für EEBD



**EEBD Box**  
500 x 216 x 149mm  
rubber catch  
red - galvanized steel - coated

**3835000**

for type: Dräger CF15

**EEBD Box**  
500 x 216 x 149mm  
mit Gummiverschluss  
rot - Stahl verzinkt - gepulvert

für Typ: Dräger CF15

Fire Protection  
*Feuerschutz*

Escape Devices  
*Fluchtgeräte*



Compressors  
Kompressoren

**Breathing Air Compressor**

technical specification:  
 - operating voltage: 230 V AC  
 - frequency: 60 Hz  
 - single-phase motor: 2,2 kW - 3 PS  
 - filling device: 2 x 330 bar  
 - TRIPLEX P21 filtersystem - DIN EN 12021  
 - with B-Timer  
 - final pressure: max. 330 bar  
 - delivery volume: 100 l/

**Atemluftkompressor**

Technische Spezifikation:  
 - Betriebsspannung: 230 V AC  
 - Frequenz: 60 Hz  
 - Wechselstrommotor: 2,2 kW - 3 PS  
 - Füllanschluß: 2 x 330 bar  
 - TRIPLEX P21 Filtersystem - DIN EN 12021  
 - mit B-Timer  
 - Betriebsdruck: max. 330 bar  
 - Liefermenge: 100 l/min.  
 - Komp

**1827980**

Junior-W-PN 2x330 bar (230V, 60Hz)

Junior-W-PN 2x330 bar (230V, 60Hz)

**1827990**

Junior 100-W-PN 330 bar (230 V, 50 Hz)

Junior 100-W-PN 330 bar (230 V, 50 Hz)

**1828040**

Junior 100-W-PN 330 bar (230 V, 60 Hz)

Junior 100-W-PN 330 bar (230 V, 60 Hz)

**1828053**

Junior 100-E-PN 330 bar (440 V, 60Hz)

Junior 100-E-PN 330 bar (440 V, 60Hz)

**1828060**

Junior 100-E-PN 330 bar (230 V, 60 Hz)

Junior 100-E-PN 330 bar (230 V, 60 Hz)

**1828070**

Junior 100-W-PN 225/330 bar (230 V, 60 Hz)

Junior 100-W-PN 225/330 bar (230 V, 60 Hz)

Spare Parts Compressors  
Ersatzteile Kompressor



**Filter**  
for BAUER compressors

**Filter**  
für Bauer Kompressoren

**1826900**

type: Triplex 057679-410

Typ: Triplex 057679-410



**Filter Cartridge**

**Filterpatrone**

**1826910**

type: N70 - Bauer

Typ: N 70

Spare Parts Compressors  
*Ersatzteile Kompressor*



**Allround Lubricant**  
WEICON type: AL-H  
formally WEICON WP 300 white  
400ml

**1827914**

Typ: N19752

**Hochtemperaturfettspray**  
WEICON Typ: AL-H  
ehemals WEICON WP 300 weiß  
400ml

Typ: N19752

Special Armatures  
*Spezial Armaturen*



**Water Fog Applicator**  
aluminium

**3811000**

I = 2m - with Storz-C coupling

**3811130**

I = 1,5m - with Storz-C coupling

**Wasserstaubrohr**  
Aluminium

L = 2m - mit Storz - C Kupplung

L = 1,5m - mit Storz - C Kupplung



**Container Fire Lance**  
with hardened steel tip  
and stroke unit

**3851000**

with storz C coupling

**Feuerlöschlanze**  
mit gehärteter Stahlspitze  
und Schlagstück

mit Storz C Kupplung



**Foam Concentrate**  
frost safe up to -15°C

**1829000**

Fluorprotein 6% - 30 kg / 25 litre

**Schaumkonzentrat**  
frostbeständig bis -15°C

Fluorprotein 6% - 30 kg / 25 Liter

**Foam Concentrate**  
frost safe up to -15°C

**1829100**

F15 - synthetic 3% - 20 kg / 20,8 l

**1829450**

Protein 6% - 23 kg / 20 litre

**1829500**

Protein 3% - 23 kg / 20 litre

**1829580**

AFFF 3% - 20 kg

**Schaumkonzentrat**  
frostbeständig bis -15°C

F15 - Synthetisch 3% - 20 kg / 20,8 l

Protein 6% - 23 kg / 20 Liter

Protein 3% - 23 kg / 20 Liter

AFFF 3% - 20 kg

**Foam Nozzle**  
with Storz C aluminium coupling  
200 litre / minutes

**1829200**

type: S2 - with closing

**Schaumstrahlrohr**  
mit Storz C-Aluminium Kupplung  
200 Liter / Minute

Typ: S2 - mit Absperrung

**Injection Mixer**  
with storz C aluminium couplings  
mixture rate: 1 - 6%  
DIN 14384

**1829300**

type: Z2R

**Schaumzumischer**  
mit Storz C Aluminium Kupplungen  
Zumischrate: 1 - 6%  
DIN 14384

Typ: Z2R - Storz C

**Suction Hose for Foam Mixer**  
with storz D/25 aluminium coupling

**1829400**

1,5 m - complete

**Ansaugschlauch für Schaumzumischer**  
mit Storz D/25 Aluminium Kupplungen

1,5 m - komplett

**Foam Concentrate**  
frost safe up to -10°C

**1829600**

AFFF 6% - 25 kg

**Schaumkonzentrat**  
frostbeständig bis -10°C

AFFF 6% - 25 kg



**Fire Blanket**

**1784200**

200 x 160cm - DIN 14155

**Feuerlöschdecke**

200 x 160cm - DIN 14155



**Box**

315 x 305 x 125mm

**1784300**

for fire blanket

**Kasten**

315 x 305 x 125mm

für Feuerlöschdecke



**Aerosol Test Gas**

**1786500**

type: Hekatron - 250ml tin

**Prüfgas Aerosol**

Typ: Hekatron - 250ml Dose



**Aerosol Test Gas**

**1786501**

type: Heimi Fog 1 - 150ml tin

**Prüfgas Aerosol**

Typ: Heimi Fog 1 - 150ml Dose



**Telescope Rod**

with release device  
1,7 - 3,0 metres

**1786550**

for smokedetector testspray

**Teleskopstange**

mit Auslösekopf  
1,7 - 3,0 Meter

für Rauchmelder Prüfgas



**Firemans Axe**  
insulated

**1891000**

90cm - wooden handle

**Feuerwehraxt**  
isoliert

90cm - Holzstiel



**Firemans Axe**

**1891100**

90cm - wooden handle

**Feuerwehraxt**

90cm - mit Holzstiel



**Firemans Hatchet**  
insulated

**1891300**

36cm - DIN 14924

**Feuerwehrbeil**  
isoliert

36cm - DIN 14924



**Leather Pocket**

**1891400**

for firemans hatchet

**Ledertasche**

für Feuerwehrbeil



**Emergency Hammer**  
plastic

**1891600**

with bracket

**Nothammer**  
Kunststoff

mit Halter



**Liquid Level Indicator -  
Portable**

for marine liquid gaseous  
fire extinguishing systems  
accuracy: +/- 1,5mm  
display: LED and LCD

**1891610**

type: Portamarine

**Füllstandsmessgerät -  
Tragbar**

für flüssige und gasförmige  
Feuerlöschesysteme  
Genauigkeit: +/- 1,5mm  
LED und LCD Anzeige

Typ: Portamarine



**Fire Hose Box**  
ABS / PMMA - 5mm

**3856100**

553 x 586 x 180mm

**Schlauchschränk**  
ABS/PMMA - 5mm

553 x 586 x 180mm



Safety Equipment

*Sicherheitsausrüstung*



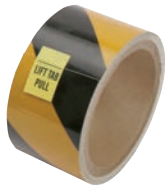

**Warning Tape**

reflective - self adhesive

**1101191**

yellow/black - 50mm - roll a 22,5m

**1101250**

yellow/black - 70mm - roll a 22,5m

**1101251**

yellow/black - 100mm - roll a 22,5m

**1101252**

yellow/black - 150mm - roll a 22,5m

**Warnband**

reflektierend - selbstklebend

gelb/schwarz - 50mm - Rolle a 22,5m

gelb/schwarz - 70mm - Rolle a 22,5m

gelb/schwarz - 100mm - Rolle a 22,5m

gelb/schwarz - 150mm - Rolle a 22,5m



**Warning Tape**

reflective - self adhesive

**1101201**

red/white - 45mm - roll a 10m

**1101261**

red / white - 90mm - roll a 10m

**1101262**

red / white - 150mm - roll a 10m

**Warnband**

reflektierend - selbstklebend

rot/weiß - 45mm - Rolle a 10m

rot / weiß - 90mm - Rolle a 10m

rot / weiß - 150mm - Rolle a 10m



**Antisplash Tape**

self adhesive

**1505001**

type: T-ISS - 35mm x 10m

**1505101**

type: T-ISS - 50mm x 10m

**1505151**

type: T-ISS - 100mm x 10m

**1505201**

type: T-ISS - 140mm x 10m

**1505301**

type: T-ISS - 250mm x 10m

**Antisplash Tape**

selbstklebend

Typ: T-ISS - 35mm x 10m

Typ: T-ISS - 50mm x 10m

Type: T-ISS - 100mm x 10m

Typ: T-ISS - 140mm x 10m

Typ: T-ISS - 250mm x 10m



**Reflective Tape**

selfadhesive  
with MED-approval

**1832000**

type: 3M - 50mm - yardware

**1832100**

type: 3M - 50mm x 50m

**1832103**

type: 3M - 50mm x 25m

**Reflexfolie**

selbstklebend  
mit MED-Zulassung

Typ: 3M - 50mm - Meterware

Typ: 3M - 50mm x 50m

Typ: 3M - 50mm x 25m



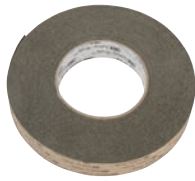

**Anti Slip Foil**  
25mm x 18,3m

**1832300**

type: SAFETY WALK

**Antirutschfolie**  
25mm x 18,3m

Typ: SAFETY WALK



**Duct Tape**  
self adhesive

**1899100**

75mm x 50m - silver

**1899120**

50mm x 50m - silver

**Gewebeband**  
selbstklebend

75mm x 50m - silber

50mm x 50m - silber



**Warning Tape**  
Nitrogen - Do not enter  
reflective - self adhesive

**TB40390**

red / white - 40mm - roll a 25m

**Warnband**  
Nitrogen - Do not enter  
reflektierend - selbstklebend

rot / weiß - 40mm - Rolle a 25m



**Shovel**  
aluminium

**1500500**

wide: 32 cm - wooden handle

**Schaufel**  
Aluminium

Breite: 32 cm - mit Holzstiel



**Oil Absorbing Pads**  
200 pieces / pack  
ENV 200 M

**1501000**

41 x 51cm / 21ltr

**Ölsaugtuch**  
200 Stück / Paket  
ENV 200 M

41 x 51cm / 21 Liter



**Oil Sorbent Booms**  
4 pieces / pack  
SPC 510

**1501100**

13 cm x 3 m / 119 litre

**Ölschläuche**  
4 Stück / Packet  
SPC 510

13 cm x 3 m / 119 Liter



**Oil Sorbent Sweep**  
1 roll / bale  
SPC 1900

**1501200**

48 cm x 30,5 m / 94 litre

**Ölschleier**  
1 Rolle  
SPC 1900

48 cm x 30,5 m / 94 Liter



**Oil Sorbent Booms**  
12 pieces / pack  
OIL 412

**1501300**

7,6 cm x 1,22 m / 43 Litre

**Ölschläuche**  
12 Stück / Packet  
OIL 412

7,6 cm x 1,22 m / 43 Liter



**Oil Sorbent Pillow**  
32 pieces / pack  
AW 99

**1501390**

23 x 23cm / 52 litre

**Ölsaugkissen**  
32 Stück / Paket  
AW 99

23 x 23 cm / 52 Liter

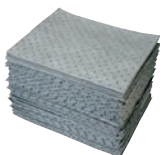

**Oil Pads**  
100 pieces / pack  
MRO 100 - E

**1501400**

41 x 51cm

**Öltücher**  
100 Stück / Paket  
MRO 100 - E

41 x 51cm



**Sawdust**

**1501410**

bag a 20 kg

**Sägespäne**

Sack a 20 kg



**Oil Dry Granulat**

**1501440**

bag a 20 kg

**Öl Trocken Granulat**

Sack a 20 kg



**Oil Spill Set**

for vessels more than 120m in length

**1501480**

type: OPA 12 Barrel

**Ölbekämpfungssatz**

für Frachtschiffe über 120m Länge

Typ: OPA 12 Barrel



**Oil Spill Set**

for vessels less than 120m in length

**1501481**

type: OPA 7 Barrel

**Ölbekämpfungssatz**

für Frachtschiffe unter 120m Länge

Typ: OPA 7 Barrel



**Oil Spill Emulsion**

**1501500**

canister a 10 litre

**Öl Netzmittel**

Kanister a 10 Liter



**Oil Spill Drum**

plastic

**1501510**

220 litre - with lid

**Ölentsorgungsfass**

Kunststoff

220 Liter - mit Deckel



**Pressure Sprayer**

with pump, hose and nozzle

**1501600**

5 litre

**1501610**

10 litre

**Drucksprüngerät**

mit Pumpe, Schlauch und Düse

5 Liter

10 Liter



**Box for Oil Spill Equipment**

GRP - white

**1501700**

122 x 72 x 74 cm

**Kiste für Ölbekämpfung**

GFK - weiß

122 x 72 x 74 cm



Gas Detectors - Dräger  
Gasmessgeräte - Dräger

**Gas Detector**  
only basic device  
incl. calibrate adapter  
incl. shoulder belt  
incl. pump and adapter  
Dräger No.: 8317400

**Gasmessgerät**  
Grundgerät  
inkl. Kalibrieradapter  
inkl. Tragegestell mit Schultergurt  
inkl. interner Pumpe und  
Pumpenadapter  
Dräger Nr.: 8317400

**1816110**

type: X-am 7000

Typ: X-am 7000



**Gas Detector**  
with pump  
Dräger-No.: 8317730

**Gasmessgerät**  
inklusive Pumpe  
Dräger-Nr.: 8317730

**1816200**

type: X-am 3000P EX/O<sup>2</sup>

Typ: X-am 3000P EX/O<sup>2</sup>



**Gas Detector**  
with 2 batteries AA  
Dräger-No.: 8318770  
Measurement Range:  
O<sub>2</sub>: 0 - 25 % Vol.  
EX: (LEL) 0 - 100% LEL

**Gasmessgerät**  
mit 2 Batterien AA  
Dräger-Nr.: 8318770  
Messbereiche:  
O<sub>2</sub>: 0 - 25 % Vol.  
EX: (UEG) 0 - 100% UEG

**1816270**

type: X-am 5000 EX/O<sup>2</sup>

Typ: X-am 5000 EX/O<sup>2</sup>



**Gas Detector**  
lifetime 2 years  
with 2 Batteries AA  
Dräger No.: 8318730

**Gasmessgerät**  
2 Jahre Lebensdauer  
mit 2 Batterien AA  
Dräger Nr.: 8318730

**1820090**

type: X-am 1700 EX/O<sup>2</sup>/ H<sup>2</sup>S/ CO

Typ: X-am 1700 EX/O<sup>2</sup>/ H<sup>2</sup>S/ CO



Gas Detectors - Dräger  
Gasmessgeräte - Dräger



**Gas Detection Pump**  
Dräger-No.: 6400000

**1820900**

type: ACCURO - without hose

**1820990**

type: ACCURO

**1821000**

type: ACCURO

**Gasspürpumpe**  
Dräger-Nr.: 6400000

Typ: ACCURO - ohne Schlauch

Typ: ACCURO

Typ: ACCURO



**Gas Detector**  
2 years maintenance free  
Dräger-No.: 8322004

**1821201**

type: PAC 3500 - O<sub>2</sub> / 0 - 25 Vol%

**Gasmessgerät**  
2 Jahre Wartungsfrei  
Dräger-Nr.: 8322004

Typ: PAC 3500 - O<sub>2</sub> / 0 - 25 Vol%



**Gas Detector**  
2 years maintenance free  
Dräger-No.: 8322002

**1821211**

type: PAC 3500 - H<sub>2</sub>S / 0 - 100 ppm

**Gasmessgerät**  
2 Jahre Wartungsfrei  
Dräger-Nr.: 8322002

Typ: PAC 3500 - H<sub>2</sub>S / 0 - 100 ppm



**Gas Detector**  
2 years maintenance free  
Dräger-No.: 8322000

**1821221**

type: PAC 3500 - CO / 0 - 25 Vol%

**Gasmessgerät**  
2 Jahre Wartungsfrei  
Dräger-Nr.: 8322000

Typ: PAC 3500 - CO / 0 - 25 Vol%



**Gas Detector**  
Dräger-No.: 8322008

**1821281**

type: PAC 5500 - CO / 0 - 500 ppm

**Gasmessgerät**  
Dräger-Nr.: 8322008

Typ: PAC 5500 - CO / 0 - 500 ppm



Gas Detectors - Dräger  
Gasmessgeräte - Dräger

**Gas Detector**  
Dräger-No.: 8322010

**1821291**

type: PAC 5500 - H<sup>2</sup>S / 0 - 100 ppm

**Gasmessgerät**  
Dräger-Nr.: 8322010

Typ: PAC 5500 - H<sup>2</sup>S / 0 - 100 ppm

**Gas Detector**  
Dräger-No.: 8322012

**1821301**

type: PAC 5500 - O<sup>2</sup> / 0 - 25 Vol%

**Gasmessgerät**  
Dräger-Nr.: 8322012

Typ: PAC 5500 - O<sup>2</sup> / 0 - 25 Vol%



Sensors - Dräger  
Sensoren - Dräger

**Dräger Sensor**  
maximum measuring range:  
0 - 100 Vol % - CH<sub>4</sub>  
0 - 100 % UEG  
Dräger-No.: 6810460

**1809901**

IR-Ex

**Dräger Sensor**  
Maximaler Messbereich:  
0 - 100 Vol % - CH<sub>4</sub>  
0 - 100 % UEG  
Dräger-Nr.: 6810460

IR-Ex

Accessories Dräger  
Zubehör - Dräger



**Battery**  
for PAC 3000/3500 and PAC  
5000/5500

**1446650**

type: CR123A - 3 Volt

**Batterie**  
für PAC 3000/3500 und PAC  
5000/5500

Typ: CR123A - 3 Volt



**Float Probe**  
for Dräger gasdetectors  
Dräger-No.: 6807097

**1820580**

with 10 metres hose

**Schwimmersonde**  
für Dräger Gasmessgeräte  
Dräger Nr. 6807097

mit 10 Meter Schlauch



**Spare Part Set**  
Dräger-No.: 6400220

**1820940**

for ACCURO Gas Detection Pump

**Ersatzteilset**  
Dräger-Nr.: 6400220

für ACCURO Gasspürpumpe

Accessories Dräger  
Zubehör - Dräger



**Viton Hose**  
Dräger-No.: 1203150  
**1821820**  
yardware

**Vitonschlauch**  
Dräger-Nr.: 1203150  
  
Meterware



**Load Bowl with Plug Power Pack**  
Dräger-No.: 8317763  
**1821900**  
for gas detectors X-am 3000

**Ladeschale mit Steckernetzteil**  
Dräger-Nr.: 8317763  
  
für Gasmessgerät X-am 3000



**Carrying Bag**  
with shoulder strap  
Dräger-No.: 8100228  
**1821930**  
for ACCURO Gas Detection Pump

**Bereitschaftstasche**  
mit Tragegurt  
Dräger-Nr.: 8100228  
  
für ACCURO Gasspürpumpe

Spangas  
Spanngas



**Calibrationgas**  
bottle 1 litre - 12 bar  
**1820660**  
Methane 2,5 Vol% in air

**Kalibriergas**  
Flasche 1 Liter - 12 bar  
  
Methan 2,5 Vol.% in Luft



**Dosage Valve**  
and flowmeter 0.5...1.5ltr/min  
**1820730**  
for 1ltr./12bar calibration gas bottle

**Ventil**  
mit Regler 0.5...1.5ltr/min  
  
für 1 Ltr./12bar Prüfgasdose



**Calibrationgas**  
100ppm in N<sup>2</sup> - 58 litre, 8AL  
**1820740**  
H<sup>2</sup>S

**Kalibriergas**  
100ppm in N<sup>2</sup> - 58 Liter, 8AL  
  
H<sup>2</sup>S



Alcotester / Drugtester  
Alkotester / Drogentest

**Alcotester**

content of delivery:  
- instrument  
- 3 mouthpieces  
- 2 batteries and handstrap  
Dräger-No.: 8317900

**1864200**

type: Dräger 6510

**Alkotester**

Lieferumfang:  
- Messgerät  
- 3 Mundstücke  
- 2 Batterien und Handschlaufe  
Dräger-Nr.: 8317900

Typ: Dräger 6510

**Mouthpieces**

100 pieces per package  
Dräger-No.: 6810690

**1864210**

for Dräger Alcotester type: 6510

**Mundstücke**

100 Stück pro Paket  
Dräger-Nr.: 6810690

für Dräger Alkotester Typ: 6510

**Alcotester**

packing contents:  
2 Alkaline batteries type AA  
5 mouthpieces readiness bag  
employment bag  
operating instructions in German  
and English

**1864230**

type: AlkoStar AL-6000

**Alkotester**

Verpackungsinhalt:  
2 Alkaline Batteries Typ AA  
5 Mundstücke  
Bereitschaftstasche  
Einsatztasche  
Bedienungsanleitung in Deutsch  
und Englisch

Typ: AlkoStar AL-6000

**Drug Test**

simple 5-fold spoke test with  
integrated ampul to the proof  
of Cannabis, Amphetamines

**1864235**

type: DrugWipe 5

**Drogenschnelltest**

Einfacher 5-fach Speicheltest  
mit integrierter Ampulle  
zum Nachweis von  
Cannabis, Amphetaminen

Typ: DrugWipe 5

Tubes

Prüfröhrchen

**Dräger Tubes**

**1821380**

Oxygen 5%/C - 8103261

**1822090**

Natural Gas Test - CH20001

**1822550**

Carbon Dioxide 0,1%/a - CH23501

**1822650**

Carbon Monoxide 5/c - CH25601

**1823090**

Nitrous Fumes 0,5/a - CH29401

**1823590**

Polytest - CH28401

**1823750**

Oxygen 5%/B - 6728081

**Dräger Röhrchen**

Sauerstoff 5%/C - 8103261

Erdgastest - CH20001

Kohlenstoffdioxid 0,1%/a - CH23501

Kohlenstoffmonoxid 5/c - CH25601

Nitrose Gase 0,5/a - CH29401

Polytest - CH28401

Sauerstoff 5%/B - 6728081



**First Aid Kit**

**1443400**

engine control room, bridge, kitchen

**Sanitätskasten**

*Maschinenkontrollraum / Brücke / Kombüse*



**Backpack with Medicaments IMDG**

for gas/chemistry tanker ships with dangerous goods without oxygen equipment

**1508000**

Column A, SBG - world-wide range

**Rucksack mit Arzneimitteln IMDG**

*für Gas/Chemie Tanker, Schiffe mit gefährlicher Ladung ohne Sauerstoffbeatmungsgerät*

*Column A, SBG - weltweite Fahrt*

**1508020**

Column B, SBG - coastal travel

*Column B, SBG - mittlere Fahrt*



**Oxygen Respirator**

comprising  
1 x pressure reducer  
4 x LPD adjustment  
2 x oxygen cylinders 2ltr/each  
1 x set masks (10pc)

**1510100**

in carrying bag

**Sauerstoff - Beatmungsgerät**

*bestehend aus  
1x Druckminderer  
mit 4 LPM Festeinstellung  
2x Sauerstoff Flasche a 2ltr  
1x Set Masken (10 Stück)  
nach MFAG*

*komplett in Tasche*



**Eye Wash Bottle**

empty

**1811700**

750ml with wall bracket

**Augenspülflasche**

*ohne Inhalt*

*750ml mit Wandhalter*



**Eye wash Liquid**

**1811800**

250ml

**Augenspülflüssigkeit**

250ml



**Rescue Stretcher - 2 pieces**

hoistable  
SBG-approved

**1815111**

with vacuum mattress

**Krankentrage - 2-teilig**

*und Heißgeschirr  
SBG-zugelassen*

*mit Vakuummatratze*

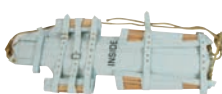

**Rescue Marine Stretcher**

**1815120**

Neil Robertson

**Krankentransporttrage**

*Neil Robertson*



Survival Sets  
Überlebens-Sets

**Heater**  
230V - 1000/2000W  
controllight, tilting protection,  
thermostat

**1341303**

type: AEG - HS203T - white

**Heizlüfter**  
230V - 1000/2000W  
Kontrolleuchte, Umkippschutz,  
Thermostat

Typ: AEG - HS203T - weiß



**Mebrane reservative - 100gr.**

type: Katadyn Survivor 35

**1509599**

for desalinator

**Biocid - 100gr.**  
Typ: Katadyn Survivor 35- LS

für Salzwasseraufbereiter -  
Handbetrieb



**Desalinator**  
dimensions: 14.0 x 55.9 x 8.9cm  
output: 4.5 l/h (± 15%)  
salt rejection (average): 98.4% (min.  
95.3%)  
technology: reverse osmosis  
stainless steel  
=====

**1509600**

type: Katadyn Survivor 35

**Salzwasseraufbereiter -  
Handbetrieb**

Technologie: Umkehrosmose  
Leistung: ca. 4,5 l/h  
Gewicht: 3,2kg  
Abmessungen: 14 x 56 x 9cm  
Edelstahl  
=====

Ohne Biocid

=====

Typ: Katadyn Survivor 35- LS



**Towel**  
quality: 440g/qm  
50 x 100cm

**1509601**

100% cotton

**Frottierhandtuch**

Qualität: 440g/qm  
50 x 100cm

100% Baumwolle



**Micro Fiber Sleeping  
Blanket**

colour: antrazit  
200 x 150cm

**1509602**

100% polyester

**Mikrofaser Schlafdecke**

Farbe: antrazit  
200 x 150cm

100% Polyester



**Single use Toothbrush**

package a 100 pcs.

**1509603**

with paste

**Einmal Zahnbürste**

Paket a 100 Stück

mit Paste



Survival Sets  
Überlebens-Sets



**Sleeping Bag**

top side: 185 T soft polyesters  
interior fodder: 100% polyester  
filling: 300gr./m<sup>2</sup> Hollowfibre  
dimensions: 230 x 80 x 55cm  
packing dimensions: 44x22cm

1509606

type: Trekker

**Schlafsack**

Oberseite: 185 T Soft-Polyester  
Futter: 100% Polyester  
Füllung: 300gr./m<sup>2</sup> Hollowfibre, 2-lagig  
Masse: 230 x 80 x 55cm  
Packmaße 44x22cm

Typ: Trekker



**Thermal Mat**

selfblowing up  
welded surface  
repair patch  
cover for valve  
dimensions: 200x66x6cm  
packing dimensions: 70 x 18cm

1509607

open-cellular PU foam

**Thermomatte**

Selbstaufblasend  
Oberfläche verschweißt  
Reparatur-Flicken  
Ersatzventilkappe  
Masse: 200x66x6cm  
Packmaß: 70 x 18cm

Offenzelliger PU Schaum



**Mobil Chemical Toilett**

Thetford - light grey  
dimensions: 414 x 383 x 427mm  
freshwatertank: 15 Litre  
wastewater tank: 21 Litre

1509608

type: Porta Potty 165 Qube

**Mobiles Chemie WC**

Thetford - lichtgrau  
Abmessung: 414 x 383 x 427mm  
Frischwassertank: 15 Liter  
Abwassertank: 21 Liter

Typ: Porta Potty 165 Qube



**Toilett Paper**

package a 4 rolls

1509609

type: Aqua Soft - Thetford

**Toilettenpapier**

Paket a 4 Rollen

Typ: Aqua Soft - Thetford

Survival Sets  
Überlebens-Sets



**Aqua-KEM Blue**  
2,0 Litre

1509610

additive for wastewater tank -  
chemistry toilet

**Aqua-KEM Blue**  
2,0 Liter

Zusatz für Abwassertank -  
Chemietoilette



**Aqua-Rinse**  
1,5 Litre

1509611

additive for freshwater tank -  
chemistry toilet

**Aqua-Rinse**  
1,5 Liter

Zusatz für Frischwassertank -  
Chemietoilette



**Cartouche Digester**  
power consumption: 1,3kW

1509612

with Pizo ignition

**Kartuschenkocher**  
Leistung: 1,3kW

mit Pizozündung

Survival Sets  
Überlebens-Sets



**Gas Cartridge**  
190 gramms  
according to EN 417

**1509613**

for cartouche digester

**Gaskartusche**  
190 Gramm  
gemäß EN 417

für Kartuschenkocher



**One Way Lighter**

**1509614**

**Einwegfeuerzeug**



**Sleeping Goggle**

**1596004**

type: Perfect Dream

**Schlafbrille**

Typ: Perfect Dream



**Cards**  
320gr / m<sup>2</sup> - 59 x 92mm  
packed in cellophan

**1596015**

2 x 55 Blatt

**Doppel Rommé Kartenspiel**  
320gr / m<sup>2</sup> - 59 x 92mm  
Verpackt in Cellophan

2 x 55 Blatt



**Gamble Set**  
100 classic games in one Set

**1596016**

type: Spielesammlung 100(NB)

**Spiele-Set**  
100 klassische Spiele in einem Set

Typ: Spielesammlung 100(NB)



**Sudoku Set**

**1596017**

192 pages

**Sammelband Sudoku**

192 Seiten



**Thermocup**  
0,35 l, Ø: 76 mm, hight 180 mm  
plastic - inclusive lid

**1596018**

type: GreenClever

**Thermobecher**  
0,35 l, Ø: 76 mm, Höhe 180 mm  
inkl. Deckel mit Trinköffnung.

Typ: GreenClever



Survival Sets  
Überlebens-Sets

**Throwing Line**

D = 8mm  
galv. carabiner on both ends

**1596027**

perlon - 50m

**Wurfleine**

D = 8mm  
beidseitig mit verz. Karabiner

Perlon - 50m



**Liquid Soap**

**1596028**

250ml

**Flüssigseife**

250ml



**Desinfection Tissuis**

box a 40 pieces

**1596036**

type: Sagrotan

**Desinfektionstücher**

Spenderbox a 40 Tücher

Typ: Sagrotan



**Rope Edge Protection**

with volcro front fastening and loop

**1596037**

l = 1m

**Seilkantenschutz**

mit Klettverschluss und Schlaufe

L = 1m



**Tarpaulin**

material: VALMEX 7539 airtex  
magic FR  
heavy inflammable according to DIN  
4102 B1

**1596039**

d=5,6m - with circulating rings all  
50cm

**Abdeckplane**

Material: VALMEX 7539 airtex  
magic FR  
Schwer entflammbar nach DIN 4102  
B1

D=5,6m - mit umlaufenden Ösen  
alle 50cm



**Box C - (Toilett/Rescue)**

8 Persons - 5 days

**1596103**

for Survival Kit

**Kiste C - (Toilette/Bergung)**

8 Personen - 5 Tage

für Überlebens - Set

A photograph of a large white and blue ship, likely a ferry or cargo vessel, with an orange lifeboat and a yellow crane on deck. The ship is viewed from a low angle, showing the upper decks and the hull. The background is a clear blue sky. A dark blue semi-transparent banner is overlaid on the bottom half of the image, containing the text.

General ship  
Equipment

*Allgemeine  
Schiffsausrüstung*





First Aid Kits  
Sanitätskästen

**First Aid Kit**  
for lifeboat

**1443200**

according to SBG

**Sanitätskasten**  
für Rettungsboot

gemäß SBG



**First Aid Kit**  
for lifeboats

**1443300**

according to SOLAS

**Sanitätskasten**  
für Rettungsboot

gemäß SOLAS



**First Aid Kit**

**1443450**

DIN 13157 - with wall bracket

**Sanitätskasten**

DIN 13157 - mit Wandhalter



**First Aid Kit**  
for inland waterways  
up to 300 persons

**1443451**

DIN 13169

**Sanitätskasten**  
für Binnenschifffahrt bis  
300 Personen

DIN 13169



**Sea Sickness Tablets**

**1448800**

package a 50 pieces

**Seekrankheitstabletten**

Paket a 50 Stück

Canisters  
Kanister



**Canister**  
plastic

**1426000**

5 litre

**1426100**

10 litre

**1426200**

25 litre

**Kanister**  
Kunststoff

5 Liter

10 Liter

25 Liter



Canisters  
*Kanister*

**Freshwater Canister**  
with dipper

1433000

30 litre



**Trinkwasserkanister**  
mit Plumpe

30 Liter

**Drinking Cup**  
plastic

1435000

with scale and chain



**Trinkbecher**  
Kunststoff

mit Messeinheit und Kette

**Bottle**  
plastic

1520900

1,0 litre



**Flasche**  
Kunststoff  
ohne Inhalt

1,0 Liter

**Petrol Canister**  
with filling tap  
steel

1524000

20 litre - military type



**Benzinkanister**  
mit Füllstutzen  
Stahl

20 Liter - Militärtyp

Spring Valve  
*Lenzventil*

**Drain Valve**  
brass

1421000

complete



**Lenzventil**  
Messing

komplett



Storm Lanterns  
*Sturmlaterne*

**Storm Lantern**  
galvanized steel

**1854200**

5 linig

**Sturmlaterne**  
Stahl verzinkt

5 linig



**Spareglass**  
for storm lantern

**1854500**

clear - 5 linig

**Ersatzglas**  
für Sturmlaterne

klar - 5 linig



**Wick**  
for storm lantern

**1854610**

1,0 m - 5 linig

**3507200**

3 linig - for storm lantern

**Docht**  
für Sturmlaterne

1,0 m - 5 linig

3 linig - für Sturmlaterne



**Spareglass**  
for storm lantern

**1854700**

gelb - 5 linig

**Ersatzglas**  
für Sturmlaterne

gelb - 5 linig



**Tin**  
galvanized steel

**3561100**

for storm lantern

**Dose**  
Stahl verzinkt

für Sturmlaterne

Boat Care  
Bootspflege



**Acrylic Scratch Remover**

**Acryglas Kratzer Entferner**

1410950

250ml

250ml



**Boat Polish**

**Bootspolitur**

1410980

500ml

500ml



**Boat Wax**

**Bootswachs**

1410990

300g

300g



**Repair Kit**

**Reparaturset**

1448100

for GRP lifeboat

für GFK Rettungsboot

Throwing Lines  
Wurfleinen



**Heaving Line**

**Wurfleine**

1415000

30m - floating

30m - schwimmfähig

1415300

50m - floating

50m - schwimmfähig



**Heaving Line**  
on one side spliced  
orange / black

**Wurfleine**  
einseitig gespleißt  
orange / schwarz

1415003

30m - floating

30m - schwimmfähig



Throwing Lines  
Wurfleinen

**Line Throwing Container**  
according to § 15.09 BinSchUO,  
for lifebuoys  
according EN 14144

**1415005**

type: Manu 30 - 30m

**Wurfleinenbehälter**  
nach § 15.09 BinSchUO,  
für den Rettungsring  
gemäss EN 14144

Typ: Manu 30 - 30m



**Heaving Line**  
orange / black

**1415020**

220m - floating

**Wurfleine**  
orange / schwarz

220m - schwimmfähig



**Heaving Line**  
with rescue quoit

**1415100**

30m - floating

**Wurfleine**  
mit Wurfring

30m - schwimmfähig



**Heaving Line**  
with sand bag

**1415200**

30m - floating

**Wurfleine**  
mit Sandsack

30m - schwimmfähig

Daylight Signal Mirrors  
Tagesignalspiegel



**Daylight Signal Mirror**  
approval number: 427.005 - BG-  
Verkehr

**3311000**

100 x 100mm - stainless steel

**Tagessignalspiegel**  
Zulassungsnummer: 427.005 - BG-  
Verkehr

100 x 100mm - komplett

Other Inventory  
Sonstiges Inventar



**Compass - Complete**  
brass - grey painted  
for lifeboat

**1410100**

with binnacle and lighting

**Kompass - komplett**  
Messing - grau lackiert  
für Rettungsboot

mit Haube und Beleuchtung



**Binnacle**  
brass - grey painted  
for lifeboat

**1410200**

with lighting

**Kompasshaube**  
Messing - grau lackiert  
für Rettungsboot

mit Beleuchtung



**Binnacle**  
brass - polished  
for lifeboat

**1410201**

with lighting

**Kompasshaube**  
Messing - poliert  
für Rettungsboot

mit Beleuchtung



**Compass**  
rose dia 100mm  
total dia 150mm

**1410300**

for lifeboat

**Kompass**  
Durchmesser gesamt: 150mm  
Rosendurchmesser: 100mm

für Rettungsboot



**Compass**  
black  
with black conical rose

**1410310**

type: Offshore 95

**Kompass**  
schwarz  
mit schwarzer konischer Rose

Typ: Offshore 95



**Detailed Sighting Compass**  
magnifying mirror and sighting  
magnifier and measuring scales in  
millimetres and inches.  
romer scales 1:50.000 and 1:25.000

**1410400**

type: 15 T

**Peilkompass**  
Klassischer Peilkompass  
Vergrößerungsspiegel und  
Peilöffnung  
Lupe, Millimeter/Inch Maßstab  
Kartenmaßstäbe 1:50.000, 1:25.000

Typ: 15 T

Other Inventory  
Sonstiges Inventar



**Release hook**  
without load  
for liferafts / rescue boats  
with MED approval

1411250

type: OLH13 - 1,1 to - 13 KN

**Auslösehaken**  
ohne Belastung  
für Rettungsboot / Rettungsinsel  
mit MED Zulassung

Typ: OLH13 - 1,1 to - 13 KN



**Release Hook**  
on load  
for liferaft / rescue boat  
with MED approval

1411300

type: RH20 - 1,1to - 18KN

**Auslösehaken unter Last**  
für Rettungsboot / Rettungsinsel  
mit MED Zulassung

Typ: RH20 - 1,1to - 18KN



**Release Hook**  
for rescue boats  
with MED approval

1411350

type: SIMPLEX - 1,1to

**Auslösehaken**  
für Rettungsboot  
mit MED Zulassung

Typ: SIMPLEX - 1,1to



**Oil Bag**

1413000

with line

**Ölbeutel**

mit Leine



**Sea Anchor**  
with weatherproof fabric

1413100

with 2 floating lines a 30 m

**Treibanker**  
aus wetterfestem Gewebe

mit 2 Schwimmleinen a 30m



Other Inventory  
*Sonstiges Inventar*



**Wave Calming Oil**

**1413500**

10 litre

**1413600**

5 litre

**1413800**

25 litre

**Wellenberuhigungsöl**  
Kanister

10 Liter

5 Liter

25 Liter



**Bailer**

**1423000**

plastic

**Ösfass**

Kunststoff



**Bucket**

**1423400**

7,5 litre - rubber

**Schlagpütz**

7,5 Litre - Gummi



**Pump**  
light duty

**1423980**

for lifeboat

**Pumpe**  
leichte Ausführung

für Rettungsboot



**Pump**  
heavy duty

**1424000**

for lifeboat

**Pumpe**  
schwere Ausführung

für Rettungsboot



**Hose**  
for life boat pump

**1424100**

3,0 m - with suction strainer

**Schlauch**  
für Rettungsbootpumpe

3,0 m - mit Saugkorb



**Suction Strainer**  
brass

**1424110**

with hose nozzle

**Saugkorb**  
Messing

mit Schlauchtülle



Other Inventory  
Sonstiges Inventar

**Hose**  
for lifeboat pump  
yardware

1424120

PVC - 38mm - transparent

**Schlauch**  
für Rettungsbootpumpe  
Meterware

PVC - 38mm - klar



**Floater**

1425100

for grip line

**Schwimmer**

für Greifleine



**Row Lock**  
galvanized steel

1425600

70 mm - hinged

**Rudergabel**  
Stahl verzinkt

70 mm - klappbar



**Row Lock**  
galvanized steel

1425800

75 mm - straight

**Rudergabel**  
Stahl verzinkt

75 mm - fest



**Oar**  
wood

1427400

4,20 m

**Bootsriemen**  
Holz

4,20 m



**Paddle**  
wood

1427800

1,25 m

**Stechpaddel**  
Holz

1,25 m

Other Inventory  
Sonstiges Inventar



**Emergency Ration**

**1431200**  
500gr. - 10.000Kj

**Notproviant Ration**

500gr. - 10.000Kj



**Drinking Water Ration**  
in plastic bag  
10 portions a 50ml

**1435100**  
Seven Ocean - 500ml

**Trinkwasser Ration**  
in Kunststoffbeutel  
10 Beutel a 50ml

Seven Ocean - 500ml

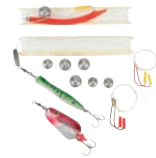

**Fishing Tackle**

**1441000**  
SBG approval

**Fischfangerät**

SBG Zulassung



**Emergency Fishing Set**  
line holder, 5 hooks  
lead, plastic bag

**1441011**  
line - 75m

**Fischfangerät**  
Plastikwinde, 5 Haken,  
Blei, eingeschweißt

Schnurlänge - 75m



**Thermal Protective Aid**

**1442000**  
TPA

**Kälteschutzanzug**

TPA



**Hatchet**

**1443000**  
with protective cover

**Kappbeil**

mit Schutzkappe



Other Inventory  
Sonstiges Inventar

**Jacknife**  
stainless steel  
**1444000**  
11 parts

**Klappmesser**  
Edelstahl  
  
11-teilig



**Jacknife**  
with marlinspike + tin opener  
stainless steel  
**1444100**  
3-parts

**Klappmesser**  
mit Marlspieker + Dosenöffner  
Edelstahl  
  
3-teilig



**Knife Floating**  
**1444120**  
for liferaft / lifeboat

**Schwimmmesser**  
  
für Rettungsinsel / Rettungsboot



**Sewing Kit**  
**1448000**  
for lifeboat

**Nähzeug - Set**  
  
für Rettungsboot



**ID-Card Container**  
plastic  
**1448200**  
watertight - for liferafts

**ID-Card Behälter**  
Kunststoff  
  
wasserdicht - für Rettungsinseln



**Sea Sickness Bag**  
**1448700**

**Spucktüte**

Other Inventory  
Sonstiges Inventar

**Sailors Knife**



**1814000**

with leather sheath

**Kappmesser**

mit Lederscheide

**Storm Matches**  
sealed package



**1935000**

25 pieces per package

**Sturmstreichhölzer**  
eingeschweißt

25 Stück per Schachtel

**Lightstick**  
burning time: 6-8 hours



**1991600**

green - 15cm

**Leuchtstab**  
Brenndauer: 6-8 Stunden

grün - 15cm

**Lightstick - Cyalume**  
burning time: 6-8 hours



**1991601**

white - 15cm

**Leuchtstab - Cyalume**  
Brenndauer: 6-8 Stunden

weiß - 15cm



**Binoculars**  
*Ferngläser*

**Binocular**  
for day and dawn / twilight  
central focussing rubber protected  
with carrying bag

**1125000**

type: Otisane - 7x50

**Fernglas**  
*Mitteltrieb - gummiarmiert*  
*Tag- und Dämmerung*  
*Tragetasche*

Typ: Otisane - 7x50



**Binocular**  
binnacle  
centre-wheel focusing  
individual eyepiece dioptre  
adjustment  
tripod adapter thread  
individual adjustable eyecups (pop-  
up)  
waterproof housing  
rubber armouring  
inclusive real leather bag  
floatation strap  
graticule plate

**1125020**

type: Binocom 7x50 CLS

**Fernglas**  
*Kompass*  
*Mitteltrieb-Fokussierung*  
*Dioptrien-Ausgleich*  
*Stativ-Anschlussgewinde*  
*Umstülpbare Augenmuscheln*  
*Wasserdicht*  
*gummiarmierter Fernglaskörper*  
*Echtleder-Tasche und Schwimmgurt*  
*Strichplatte*

Typ: Binocom 7x50 CLS



**Binocular**  
compass  
single focusing  
individual eyepiece dioptre  
adjustment  
tripod adapter thread  
individual adjustable eyecups (pop-  
up)  
waterproof housing  
rubber armouring  
inclusive real leather bag  
floatation strap

**1125050**

type: Binocom 7x50 GAL

**Fernglas**  
*Kompass*  
*Einzel-Fokussierung*  
*Stativ-Anschlussgewinde*  
*Umstülpbare Augenmuscheln*  
*Wasserdicht durch Stickstoff-*  
*Füllung*  
*gummiarmierter Fernglaskörper*  
*Echtleder-Tasche und Schwimmgurt*

Typ: Binocom 7x50 GAL



**Binocular**  
watertight up to 2m  
Sport - Auto - Focus

**1125150**

type: Steiner - Navigator - 7x50

**Fernglas**  
*Wasserdicht bis 2m*  
*Sport - Auto - Focus*

Typ: Steiner - Navigator - 7x50



**Binocular**  
exit pupil 7.1 mm  
geometrical luminous intensity 51  
dämmerungszahl 18,7  
field of view on 1000 m 130 m  
subj. Visual angle 52 °  
close attitude border 6.5 m  
AP-situation of 18 mm  
eye width 53 - 78 mm

**1125151**

type: Zeiss - T\* Marine - 7 x 50 GA

**Fernglas**  
*Austrittspupille 7,1 mm*  
*Geometrische Lichtstärke 51*  
*Dämmerungszahl 18,7*  
*Sehfeld auf 1000 m 130 m*  
*Subj. Sehwinkel 52 °*  
*Naheinstellgrenze 6,5 m*  
*AP-Lage 18 mm*  
*Augenweite 53 - 78 mm*

Typ: Zeiss - T\* Marine - 7 x 50 GA



Thermometer  
*Thermometer / Psychrometer*



**Hygrometer**  
320 x 80 mm - wall mounting  
humidity: 0% to 100%

**1510300**

temperature: -30°C to 60°C

**Hygrometer**  
320 x 80 mm - Wandmontage  
Feuchte: 0% to 100%

Temperatur von: -30°C bis 60°C



**Precision Sling Psychrometer**  
humidity: 0%...100%  
length: 425 mm  
with leather bag

**1510310**

temperature: -5°C...+50°C

**Psychrometer - Schleudertyp**  
Feuchte: 0%...100%  
Länge: 425 mm  
mit Ledertasche

Temperatur von -5°C...+50°C



**Test Slat Thermometer**  
graduation 0.5°C  
length: 38 cm

**1510330**

temperature: -10°C...+200°C

**Prüfstabthermometer**  
Teilung 0,5°C  
Länge: 38 cm

Temperatur von -10°C...+200°C



**Thermometer**  
for bridge wings  
brass tube  
DHI Class II

**1510340**

-38°C...+50°C

**Thermometer**  
für Brückennock  
in Messinghülse  
DHI Class II

-38°C...+50°C



Thermometer  
*Thermometer / Psychrometer*

**Thermometer**  
for cargo hold + tank  
bass housing - with dipper

**1510350**

-10°C...+100°C at 0.5°C

**Thermometer**  
für Laderaum + Tank  
in Messinggehäuse mit Schöpfer

-10°C...+100°C bei 0.5°C



**Thermometer**  
for air and water  
marine type - in wood tube

**1510360**

-38°C...+50°C

**Thermometer**  
für Luft und Wasser  
Marine Typ - in Holzfassung  
-38°C...+50°C

-38°C...+50°C



**Polymer Thermo- /  
Hygrometer**  
red liquid

**1510370**

-50°C...+50°C at 1°C

**Polymer - Thermo- /  
Hygrometer**  
rote Füllung

-50°C...+50°C in 1°C

Thermometer  
*Thermometer / Psychrometer*



**Thermometer**  
with roof, hook and eye  
minimum / maximum  
plastic

**1510380**

-38°C...+50°C

**Thermometer**  
mit Dach und Aufhängeöse  
Minimum / Maximum  
Kunststoff

-35°C...+50°C



**Thermometer**  
150 x 26 mm  
wooden base

**1510390**

-20°C...+50°C

**Thermometer**  
150 x 26 mm  
auf Holz

-20°C...+50°C



**Thermometer**  
for engine room  
in copper tube

**1510400**

-10°C...+110°C

**Thermometer**  
für Maschinenraum  
Kupfergehäuse

-10°C...+110°C



Thermometer  
*Thermometer / Psychrometer*

**Thermometer**  
220 x 55 mm  
on metal plate - white

**1510410**

-30°C ...+50°C

**Thermometer**  
220 x 55 mm  
auf Metallplatte - weiß

-30°C...+50°C



Watches  
*Uhren*

**Stopwatch**

**1127000**

1/100 sec. - digital

**Stoppuhr**

1/100 sec. - digital



**Stopwatch**  
wassertide

**1127020**

1/100 sec. - digital

**Stoppuhr**  
Wasserdicht

1/100 sec. - digital



**Stopwatch**  
analog - wassertide

**1127040**

1/5 sec. - 30 minutes reading

**Stoppuhr**  
analog - Wasserdicht

1/5 sec - 30 Minuten Anzeigezeit

Watches  
Uhren



**Stopwatch**  
analog - watertide  
**1127060**  
1/10 sec. - 15 minutes reading

**Stoppuhr**  
analog - Wasserdicht  
1/10 sec - 15 Minuten Anzeigezeit



**Bridge Clock**  
brass polished  
**1515100**  
150 mm - quartz

**Brückenuhr**  
Messing poliert  
150 mm - Quarz



**Bridge Clock**  
brass polished  
**1515120**  
150 mm - radio controlled

**Brückenuhr**  
Messing poliert  
150 mm - mit Funksektor



**Bridge Clock**  
brass polished  
**1515160**  
180 mm - quartz

**Brückenuhr**  
Messing poliert  
180 mm - Quarz



**Bridge Clock**  
brass polished  
**1515180**  
180 mm - radio controlled

**Brückenuhr**  
Messing poliert  
180 mm - mit Funksektor



**Bridge Clock**  
brass polished  
**1515200**  
220 mm - quartz

**Brückenuhr**  
Messing poliert  
220 mm - Quarz



**Bridge Clock**  
brass polished  
**1515220**  
220mm - radio controlled

**Brückenuhr**  
Messing poliert  
220 mm - mit Funksektor



Watches  
*Uhren*

**Bell Clock**  
8-day movement  
brass polished

1515240

150mm - mechanical

**Glasenuhr**  
8-Tage Werk  
Messing poliert

150mm - mechanisch



**ECO Boardchronometer**  
snap cover / glass pane

1515280

155 x 155 x 90mm - mahogany

**ECO Bordchronometer**  
Klappverschluss / Glaseinsicht

155 x 155 x 90mm - Mahagoni

Nautical Equipment  
*Nautische Geräte*



**Chart Divider**  
classic / basic design

1510600

180mm

**Marinezirkel**  
klassische / einfache Ausführung

180mm



**Chart Divider**  
chrom plated

1510610

180mm

**Marinezirkel**  
verchromt

180mm



**Chart Divider**  
nickel plated

1510620

185mm - gear wheel

**Marinezirkel**  
vernickelt

185mm - Zahnradführung



**Chart Divider**  
chrom plated

1510630

185mm - english style

**Marinezirkel**  
verchromt

185mm - Englischer Stil



**Chart Divider**  
chrom plated

1510640

190mm - english style

**Marinezirkel**  
verchromt

190mm - Englischer Stil



**Triangel Nautical Square**  
hypotenuse - 27cm  
grip firm

1510650

hypotenuse - 27 cm

**Anlegedreieck**  
Hypotenuse 27cm  
Griff fest

0-Punkt auf Basis



Nautical Equipment  
*Nautische Geräte*



**Triangel**  
grip firm

**1510660**

hypotenuse - 33cm

**Kursdreieck**  
Griff fest

Hypotenuse - 33cm

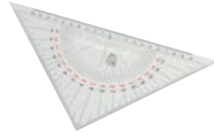

**Protector Triangel**  
grip removable

**1510670**

hypotenuse 27cm - "0" displaced

**Kursdreieck**  
Griff abnehmbar

Hypotenuse 27cm - "0" versetzt



**Protector Triangel**  
grip firm

**1510680**

hypotenuse 27cm - "0" on base

**Kursdreieck**  
Griff fest

Hypotenuse 27cm - "0" auf Basis



**Protector Triangel**  
digits in 2 colours

**1510690**

hypotenuse - 33cm

**Kursdreieck**  
2-farbig

Hypotenuse 33cm



**Chart Ruler**  
plexi glass - 3 mm

**1510700**

length: 44,5cm

**Kurslineal**  
Plexiglas - 3 mm

Länge: 44,5cm

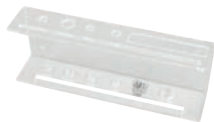

**Shelf**  
for nautical instruments  
plexiglass

**1510710**

22 x 8 x 5cm

**Besteckhalter**  
für Nautische Instrumente  
Plexiglas

22 x 8 x 5cm



**Chart Magnifier**

**1510780**

dia: 90mm

**Kartenlupe**

Durchmesser: 90mm



Nautical Equipment  
*Nautische Geräte*

**Parallel Ruler**  
plexiglass - 3mm

**1510790**

30,5cm

**1510800**

40,6cm

**1510810**

45,7cm

**1510820**

61,0cm

**Parallel Lineal**  
Plexiglas - 3mm

30,5cm

40,6cm

45,7cm

61,0cm

Salinometer  
*Salinometer*



**Load Line Hydrometer**  
for measurement of  
density / specific weight  
of seawater.

**1101430**

measuring range: 1,00 - 1,04 g/cm<sup>3</sup>  
at 15°C

**Hydrometer (Aräometer)**  
Zür Messung von Dichte/  
spezifischem Gewicht des  
Seewassers.

Messbereich: 1,00 - 1,04 g/cm<sup>3</sup> bei  
15°C

Barometer  
*Barometer*



**Aneroid Barometer**  
hinge and shutter  
brass polished

**1515000**

150mm

**Aneroid Barometer**  
Scharnier und Verschluss  
Messing poliert

150mm



**Aneroid Barometer**  
adjustment rear  
brass polished

**1515040**

155mm

**Aneroid Barometer**  
Einstellung hinten  
Messing poliert

150mm



**Aneroid Barometer**  
hinge and shutter  
brass polished

**1515060**

180mm

**Aneroid Barometer**  
Scharnier und Verschluss  
Messing poliert

180mm

Barograph  
*Barographen*



**Marine Barograph**  
8 diaphragms  
battery - quartz  
plastic case  
incl. paper recording for 1 year

**1511000**

oil dumper

**Marine Barograph**  
8 Druckdosen  
Quarz - Batterie  
Kunststoffgehäuse  
inkl. Papieraufzeichnung für 1 Jahr

Öldämpfung



**Marine Barograph**  
8 diaphragms  
battery - quartz  
mahogany case  
incl. paper recording for 1 year

**1511020**

oil dumper

**Marine Barograph**  
8 Druckdosen  
Quarz - Batterie  
Mahagonigehäuse  
inkl. Papieraufzeichnung für 1 Jahr

Öldämpfung

Megaphone  
*Sprachrohr*



**Voice hose mouth piece**  
brass

**3221000**

NW 30 - with whistle

**Sprachrohrmundstück**  
Messing

NW 30 - mit Pfeife



**Voice Hose Funnel**  
brass

**3236100**

NW 30

**Sprachrohrtrichter**  
Messing

NW 30

Other Bridge Equipment  
*Sonstige Brücke*



**Drum Sextant**

**1125550**

with lighting - wooden case

**Trommelsextant**

mit Beleuchtung - Holzkoffer



Other Bridge Equipment  
*Sonstige Brücke*

**Anemometer Digital**

1514800

type: ADC-Wind

**Handwindmesser**

Typ: ADC-Wind



**Clinometer**  
brass polished

1515300

155mm - with oil damping

**Clinometer**  
Messing poliert

155mm - mit Öldämpfung



**Radartransponder**  
SOLAS / GMDSS  
complete

1515329

type: Sart McMurdo S-4

**Radartransponder**  
SOLAS/GMDSS  
komplett

Typ: Sart McMurdo S-4



**Epirb**  
inclusive programming  
SOLAS / MED  
for the programming we need:  
- vessels name  
- MMSI number  
- call sign

1515330

type: McMurdo E5

**Epirb**  
inklusive Programmierung  
SOLAS / MED  
für die Programmierung benötigen  
wir:  
- Schiffsname  
- MMSI Nummer  
- Rufzeichen

Typ: McMurdo E5



**Handheld Marine Radio**

EEx ib IIA T3  
VHF-Band  
wasserteicht  
inclusive 230V charger  
inclusive shoulder strap

1515333

type: ICOM-M87 Atex

**Handsprechfunkgerät**

EEx ib IIA T3  
VHF-Band  
Wasserdicht  
inklusive 230V Ladegerät  
inklusive Schultergurt

Typ: ICOM-M87 Atex



**Handheld Marine Radio**

wasserdicht  
1/5 Watt power output switchable  
Lithium-Ion battery 980mAh

1515334

type: ICOM IC-M33 Euro S

**Handsprechfunkgerät**

wasserdicht  
1/5-Watt-Abgabeleistung  
schaltbar Lithium-Ionbatterie  
980mAh

Typ: ICOM IC-M33 Euro S



**Cash Box**  
DIN A4 Format

**1101010**

300x210x101mm

**Geldkassette**  
DIN A4 Format

300x210x101mm - blau



**Barrier Tape**  
wide : 60 mm  
roll a 66 m  
self adhesive

**1101070**

yellow / black

**Absperrband**  
Breite: 60 mm  
Rolle a 66 m  
selbstklebend

gelb / schwarz



**Barrier Tape**  
80 mm x 500 m  
plastic

**1101100**

red / white

**Absperrband**  
80 mm x 500 m  
Kunststoff

rot / weiß

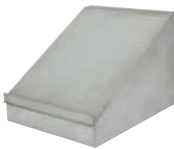

**Bureau Plate for Reeling**  
stainless steel

**1102000**

dimensions: 56 x 46 x 40cm

**Schreibpult für Reeling**  
Edelstahl

Abmessung: 56 x 46 x 40cm



**Handcuffs**

**1102200**

steel

**Handschellen**

Metall



**Whistle**  
chrom plaited

**1102220**

with lanyard and carabiner

**Trillerpfeife**  
verchromt

mit Band und Karabinerhaken

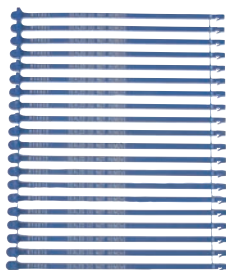

**Seal Strip**  
plastic - blue  
package a 100 pieces

**1102260**

with current number - 215mm

**Langplomben**  
Kunststoff - blau  
Paket a 100 Stück

mit fortlaufender Nummer - 215mm



**Master Key System**  
with 2 keys each  
and 2 master keys

**1102380**

3 padlocks - 50mm

**Hauptschlüsselanlage**  
je 2 Schlüssel  
und 2 Hauptschlüsseln

3 Vorhängeschlösser - 50mm



**Master Key System**  
with 2 keys each  
and 3 master keys

**1102400**

6 padlocks - 50mm

**Hauptschlüsselanlage**  
je 2 Schlüssel  
und 3 Hauptschlüsseln

6 Vorhängeschlösser - 50mm



**Master Key System**  
2 keys each  
and 3 master keys

**1102420**

12 padlocks - 50mm

**Hauptschlüsselanlage**  
je 2 Schlüssel  
und 3 Hauptschlüsseln

12 Vorhängeschlösser - 50mm



**Master Key System**  
2 keys each  
and 3 master keys

**1102440**

24 padlocks - 50mm

**1102441**

24 padlocks - 40mm

**Hauptschlüsselanlage**  
je 2 Schlüssel  
und 3 Hauptschlüsseln

24 Vorhängeschlösser - 50mm

24 Vorhängeschlösser - 40mm



**Whistle**

**1445100**

chrome

**Trillerpfeife**

Chrom

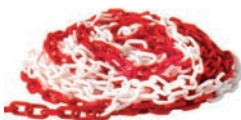

**Plastic Chain**

**1506000**

5,0m - red / white

**1506001**

50m - red / white

**Kunststoffkette**

5,0m - rot / weiß

50m - rot / weiß





**Warning Vest**  
Marked: SECURITY

**1810810**

orange - EN 471 - with Reflective Tape

**Warnweste - orange**  
Kennzeichnung: SECURITY

EN 471 - mit Reflexstreifen



**Warning Vest**  
Marked: CREW

**1810820**

orange - EN 471 - with Reflective Tape

**Warnweste - orange**  
Kennzeichnung: CREW

EN 471 - mit Reflexstreifen



**Metal Detector**  
with batteries

**1860000**

type: "Security Plus" - for persons

**Metall Detektor**  
mit Batterie

Typ: "Security Plus" - für Personen



**Name tag**

**1860020**

60 x 90mm - with clip

**Namensschild**

60 x 90mm - mit Clip



**Laminating Foil**  
package a 100 pieces

**1860021**

60 x 90mm

**Laminierfolie**  
Paket a 100 Stück

60 x 90mm



**Seal**  
package a 100 pieces

**1860060**

260 x 4,5mm - with numbers - red

**Siegel**  
Paket a 100 Stück

260 x 4,5mm - nummeriert - rot



**ISPS Mirror**  
with telescope handle 60-110 cm

**1860080**

17 x 25cm

**ISPS Spiegel**  
mit Teleskopstiel 60x110 cm

17 x 25cm



**Terminal Board**

**1860100**

A4 - plastic

**Klemmbrett**

A4 - Kunststoff



**Textile Band**  
with break section  
for nametag / whistle

**1860111**

with carabiner

**Textilband**  
mit Sollbruchstelle  
für Namensschild / Pfeife

mit Karabiner



**Transportbox**

**1124916**

for IR/UV test lamp

**Transportkoffer**

für IR/UV Testlampe



**Box**

for international shore connection  
GFP - red

**1828230**

42,5 x 32,5 x 21cm

**Kiste**

für Internationalen Landanschluss  
GFK - rot

42,5 x 32,5 x 21cm



**Box**

for Foam applicator  
GRP - red  
with bracket for canister  
and branch pipe

**1828240**

113 x 43 x 30cm

**Kiste**

für Schaumlöscheinheit  
GFK - rot  
mit Halterungen für  
Kanister und Schaumrohr

113 x 43 x 30cm



**Box**

for foam applicator  
GRP - red

**1828250**

69 x 57 x 60cm

**Kiste**

für Schaumlöscheinheit  
GFK - rot

69 x 57 x 60cm



**Box**

for 6 Lifejackets  
or 4 emergency suits  
GRP - white

**1828280**

110 x 40 x 40cm

**Kiste**

für 6 Rettungswesten  
oder 4 Überlebensanzüge  
GFK - weiß

110 x 40 x 40cm



**Box**

GRP white

**1828290**

62 x 32 x 26,5cm

**Kiste**

GFK - weiß

62 x 32 x 26,5cm



**Box**

for chemical protection suit  
with 2 handles / 4 snaps  
plastic - black

**1828320**

66 x 40 x 33cm

**Kiste**

für Chemieschutzanzug  
2 Griffe / 4 Verschlüsse  
Kunststoff - schwarz

66 x 40 x 33cm



**Box**  
for 30 Lifejackets  
or 28 emergency suits  
GRP - white

**1837580**

200 x 69 x 63cm

**Kiste**  
für 30 Rettungswesten  
oder 28 Überlebensanzüge  
GFK - weiß

200 x 69 x 63cm



**Box**  
for 26 Lifejackets  
or 24 emergency suits  
GRP - white

**1837620**

180 x 69 x 64cm

**Kiste**  
für 26 Rettungswesten oder  
24 Überlebensanzüge  
GFK - weiß

180 x 69 x 64cm



**Box - Seat**  
for 28 Lifejackets  
or 25 emergency suits  
GRP - white

**1837640**

200 x 69 x 91,5cm - seat level:  
49cm

**Kiste - Sitzbank**  
für 28 Rettungswesten oder  
25 Überlebensanzüge  
GFK - weiß

200 x 69 x 91,5cm - Sitzhöhe: 49cm



**Cabinet**  
GRP - red

**1894130**

113 x 62 x 42,5 cm

**Schrank**  
GFK - rot

113 x 62 x 42,5 cm



**Transport Box**  
outside dimensions:  
860x560x435mm  
inside dimensions: 650x485x415mm  
volumen: 153.9 litre  
waterproof by neoprene

**1894131**

type: Explorer 7641 - black

**Transportkoffer**  
Aussenmasse: 860x560x435mm  
Innenmasse: 650x485x415mm  
Volumen: 153.9 Liter  
Wasserdicht durch Neoprendichtung

Typ: Explorer 7641 - schwarz



**Transport Box**

outside dimensions:  
860x560x435mm  
inside dimensions: 650x485x415mm  
volumen: 153.9 litre  
waterproof by neoprene

**1894132**

type: Explorer 7641 - orange

**Transportkoffer**

Aussenmasse: 860x560x435mm  
Innenmasse: 650x485x415mm  
Volumen: 153.9 Liter  
Wasserdicht durch Neoprendichtung

Typ: Explorer 7641 - orange



**Transport Box**

outside dimensions:  
860x560x435mm  
inside dimensions: 650x485x415mm  
volumen: 153.9 litre  
waterproof by neoprene

**1894133**

type: Explorer 7641 - green

**Transportkoffer**

Aussenmasse: 860x560x435mm  
Innenmasse: 650x485x415mm  
Volumen: 153.9 Liter  
Wasserdicht durch Neoprendichtung

Typ: Explorer 7641 - grün



**Key Box**

steel - red

**1895000**

10 x 15,5 x 4cm

**Schlüsselkasten**

Stahl - rot

10 x 15,5 x 4cm



**Post**

l = 2,0 m  
galvanised steel

**3830800**

for lifebuoy box

**Pfosten**

L = 2,0 m  
Stahl verzinkt

für Rettungsringkasten



**Post**

10 x 6 x 200cm  
steel - red coated

**3830801**

for lifebuoy box

**Pfosten**

10 x 6 x 200cm  
Stahl - rot gepulvert

für Rettungsringkasten



**Post**

10 x 6 x 200cm  
alloy anodized

**3830900**

for lifebuoy box

**Pfosten**

10 x 6 x 200cm  
Aluminium eloxiert

für Rettungsringkasten



**Lifebuoy Box**  
ABS/PMMA - RAL3000  
inclusive wallbracket-set

**3831100**

884 x 857 x 167mm

**Retningsringkasten**  
ABS/PMMA - RAL3000  
inklusive Wandbefestigungsset

884 x 857 x 167mm



**Fireplan container**  
steel - red coated

**3853000**

10 x 32 cm

**Brandschutzplanbehälter**  
Stahl - rot

10 x 32 cm



**ISPS - Box**  
ABS / PMMA - 5mm  
inclusive stainless steel insert

**3856110**

553 x 586 x 180mm

**ISPS - Kasten**  
ABS / PMMA - 5mm  
inklusive Edelstahl Einsatz

553 x 586 x 180mm



Ex Proof Lamps  
Ex-geschützte Handlampen



**Handlamp**  
EEX ib e IIC T3 & T4  
light intensity: 8000 cd

**1851000**

type: HALO-PLUS 2 - rechargeable *Typ: HALO-PLUS 2 - Akku*

**1851100**

type: HALO-PLUS 2 - battery *Typ: HALO-PLUS 2 - Batterie*



**Handlamp**  
4-cellular  
CE marked to ATEX directive  
Eexplosive gas vapour and mist  
certified for zones 1 & 2,  
up to T4 temperature class  
dust ignition protected for  
zones 21 and 22, for dusts

**1851130**

type: Wolf H-4 DCA - ATEX -  
rechargeable

**Handlampe**  
4-zellig  
Dampf und Nebel des explosiven  
Gases  
für Zonen 1 + 2, bis zur Kategorie  
der  
Temperatur T4 Staubzündung  
geschützt  
für Zonen 21 und 22,

*Typ: Wolf H-4 DCA - ATEX - Akku*

**1851140**

type: Wolf H-4 DCA - ATEX - battery *Typ: Wolf H-4 DCA - ATEX -  
Batterie*



**Handlamp**  
EEx e s II T3  
lightness protection to IP66  
supplied with detachable shoulder  
strap

**1851150**

type: Wolf H-251A - ATEX -  
rechargeable

**Handlampe**  
EEx e s II T3  
Wasserdicht nach IP66  
mit abnehmbarem Schultergurt

*Typ: Wolf H251A- ATEX - Akku*



**LED Handlamp**  
ATEX-Code: II 1GD Ex is IIC T4  
iaD,  
Zone: 0,1,2  
5-Watt LED,  
luminous intensity: 60 lumens, 1850  
lux on 2m,  
illuminated period: approx. 100  
hours, for 3 AA batteries,

**1851155**

type: Bright Star Razor - Atex -  
battery

**LED - Handlampe**  
ATEX-Code: II 1GD Ex is IIC T4  
iaD,  
Zone: 0,1,2  
5-Watt LED,  
Lichtstärke: 60 Lumen,  
1850 Lux auf 2m,  
Leuchtdauer: ca. 100 Stunden,  
für 3 AA Batterien,

*Typ: Bright Star Razor - Atex -  
Batterie*



## Ex Proof Lamps Ex-geschützte Handlampen

### Handlamp

EN 60529 (IEC 60529): IP 65  
with battery operation: III  
certificate: PTB 99 ATEX 2063  
Category of application: II 2 G  
explosion category: EEx e ib IIC T4  
quality assurance: PTB 96 ATEX Q  
001-1

**1852100**

type: HE 8 EURO PLUS -  
rechargeable

### Handlampe

EN 60529 (IEC 60529): IP 65  
Schutzklasse: nach EN 60598 III  
PTB 98 ATEX 2063  
Richtlinie 94/9/EG: II 2 G  
Zündschutzart: EEx e ib IIC T4  
Produktion: PTB 96 ATEX Q 001-1

Typ: HE 8 EURO PLUS - Akku

**1852110**

type: HE 8 EURO PLUS - battery

Typ: HE 8 EURO PLUS - Batterie



### Handlamp

DEMKO 04 ATEX 133435  
ignition enclosure EEx ib e IIC T6  
device identification II 2 G  
enclosure IP64 after IEC 60529

**1852900**

type: Bright Star 2317C - battery

### Handlampe

DEMKO 04 ATEX 133435  
Zündschutzart EEx ib e IIC T6  
Gerätekezeichnung II 2 G  
Schutzart IP64 nach IEC 60529

Typ: Bright Star 2317C - Batterie



### Handlamp - Set

charger - 230V AC  
light achievement: 30.000cd  
Ex II 2 G EEx ib e IIB T3

**1852950**

type: Bright Star Responder  
500241A - rechargeable

### Handlampen

Ladegerät - 230V AC  
Lichtleistung: 30.000cd  
Ex II 2 G EEx ib e IIB T3

Typ: Bright Star Responder  
500241A - Akku



### Handlamp

waterproof  
ex-proof according to  
UL Class I, Division 1, Group C+D  
UL Class II, Division 1, Group G  
light intensity: 50.000 cd

**1853000**

type: Bright Star 2206 ex - US -  
battery

### Handlampe

wasserdicht  
ex-geschützt nach  
UL Class I, Division 1, Group C+D  
UL Class II, Division 1, Group G  
Lichtstärke: 50.000 cd

Typ: Bright Star 2206 ex - US -  
Batterie



### Handlamp

with 2 LR20 batteries  
light intensity: 10.000 cd  
division 1 UL & CUL approved  
waterproof

**1853070**

type: Bright Star 2217 ex-proof

### Stablampe, 2-zellig

mit 2 LR20 Batterien  
Lichtstärke: 10.000 cd  
Division 1 UL & CUL geprüft  
Wasserdicht

Bright Star 2217 / 14460 ex-  
geschützt

Ex Proof Lamps  
*Ex-geschützte Handlampen*



**Handlamp**  
ex-proof for Zone 1 und 2  
light intensity: 35.000 cd  
watertide  
marking: 94/9/EG – Ex II 2 G  
explosion category: EEx ib e IIB T3

**1853251**

type: Bright Star Responder 200401  
ATEX - battery

**Stablampe**  
ex-geschützt für Zone 1 und 2  
Leistung: 35.000 cd  
wasserdicht  
Kennzeichnung nach 94/9/EG – Ex  
II 2 G  
Zündschutzart – EEx ib e IIB T3

Typ: Bright Star Responder 200401  
ATEX - Batterie

Handlamps  
*Handlampen*



**Handlamp**  
watertight  
morse funktion

**1446000**

type: R-324 - battery

**Handlampe**  
wasserdicht  
Morsefunktion

Typ: R-324 - Batterie



**Handlamp**  
Halogen

**1446100**

type: JML 1127 HLG - battery

**Handlampe**  
Halogen

Typ: JML 1127 HLG - Batterie

**1446150**

type: JML 1127 HLG - rechargeable

Typ: JML 1127 HLG - Akku



**LED Torch**

**1596040**

type: Pansan - battery

**LED Handlampe**

Typ: Pansan - Batterie



**Handlamp**  
impact resistant plastic ribbed casing  
resistant to most chemicals, oils and fats  
safety switch to prevent unintentional activation  
impact resistant lens  
durable ring hanger  
anti-roll construction

**1853100**

type: Bright Star 2618 - battery

**Handlampe**  
Gehäuse aus schlagzähem Kunststoff  
Resistent gegen die meisten Chemikalien, Öle und Fette  
ein Schalterschutz vor unbeabsichtigtem Einschalten der Lampe  
schlagfeste Linse  
robuster Aufhängering

Typ: Bright Star 2618 - Batterie



**Handlamp**  
2 lamp functions (LED or Halogen)  
Plus wall bracket/charging station

**1853211**

type: Ansmann SL- ASN15HD Plus

**Handlampe**  
2 Leuchtmittel (LED + Halogen)  
Inklusive Wandhalterung/  
Ladestation

Typ: Ansmann SL- ASN15HD Plus



Accessories  
Zubehör

**Battery Charger**  
for handlamp Wolf H-251A

**1851160**

type: Wolf C-251HVE (230/115V)

**Ladegerät**  
für Handlampe Wolf H-251A

Typ: Wolf C-251HVE (230/115V)



**Battery Charger**  
wall version

**1851600**

for HALO-PLUS 2

**Ladegerät**  
Wandversion

für HALO-PLUS 2



**Battery Charger**  
plug version

**1852200**

for handlamp HE 8 EURO PLUS

**Ladegerät**  
Steckversion

für Handlampe HE 8 EURO PLUS



**Cone**  
red

**1853120**

type: Bright Star 2618/2217

**Leuchtkonus**  
rot

Typ: Bright Star 2618/2217

Docked vessel lights  
Festliegerleuchte



**Docked Vessel Light**  
with key

**1529010**

type: Nissen - 6V - without battery

**Festliegerleuchte**  
mit Schlüssel

Typ: Nissen - 6 V - ohne Batterie



**Bulb**  
for docked vessel light

**1529020**

6 Volt - 0,6 Ampere

**Glühlampe**  
für Festliegerleuchte

6 Volt - 0,6 Ampere

Docked vessel lights  
*Festliegerleuchte*



**Bracket**  
thief proof

**1529100**

for docked vessel light

**Halter**

Diebstahlsicherung

für Festliegerleuchte



**Tool**

**1529200**

for docked vessel light

**Schlüssel**

für Festliegerleuchte



**Battery**

110 x 70 x 70mm  
for Docked vessel light

**1529300**

6 Volt - 4R25 spring

**Batterie**

110 x 70 x 70mm  
für Festliegerleuchte

6 Volt - 4R25 Spring

Search Lights  
*Scheinwerfer*



**Rechargeable Battery**

with battery charger 220/230V  
with carrying bag  
with concentric plug  
for IBAK Searchlight

**1851950**

type: ABT224 - 24 Volt - 6,5 Ah

**1851970**

type: ABT212 - 12 Volt - 13 Ah

**Akku**

mit Ladegerät 220/230V  
mit Tasche  
mit konzentrischer Steckdose  
für IBAK Such-/  
Tagessignalscheinwerfer

Typ: ABT224 - 24 Volt - 6,5 Ah

Typ: ABT 212 - 12 Volt - 13 Ah



**Searchlight**

halogen  
3m cable and morse key  
for life boats  
with MED approval

**1852000**

type: Aqua - 12 V - 50 W - PAR 36

**Suchscheinwerfer**

Halogen  
3m Kabel und Morsetaste  
für Rettungsboot  
mit MED Zulassung

Typ: Aqua - 12 V - 50 W - PAR 36



## Search Lights Scheinwerfer

### Searchlight

rechargeable battery  
power intensity: 2,5 millions cd  
illuminated period:  
55W - 25Min  
10W - 2,5Std.  
battery: 6V - 4.0 ah  
inclusive 230/110V AC and 12V DC  
charging cable

**1852010**

type: Guardsman - MTG3307

### Suchscheinwerfer

wiederaufladbar  
Leistung: 2,5 Mio cd  
Leuchtdauer:  
55W - 25Min  
10W - 2,5Std.  
Batterie: 6V - 4,0 Ah  
inkl. 230/110V AC und 12V DC  
Ladekabel

Typ: Guardsman - MTG3307



### Carryingbag

for search lights  
type: NHS200 and NHS200H

**1852030**

type: IBAK - AT200

### Tragetasche

für Tagessignalscheinwerfer  
Typ: NHS200 und NHS200H

Typ: IBAK - AT200



### Search Light

approval: BSH 14/01/1/92  
material: polycarbonate  
type of enclosure: IP55 to EN 60529  
reflector: parabolic glass Ø150 mm  
sighting device  
connection cable with concentric  
plug  
halogen lamp 12V - 20W  
range: > 180 m

**1852051**

type: IBAK - NHS200 - 12 V

**1852061**

type: IBAK - NHS200 - 24 V

### Suchscheinwerfer

Zulassung: BSH 14/01/1/92  
Material: Polycarbonat  
Schutzart: IP55 nach EN 60529  
Reflektor: Glasparabol Ø 150 mm  
Visiereinrichtung  
Anschlußkabel mit konzentrischem  
Stecker  
Halogenlampe - 12V - 20W  
Reichweite: > 180m

Typ: IBAK - NHS200 - 12 V

Typ: IBAK - NHS200 - 24 V



### Day Signal-Search Light

with bag  
approval: BSH/4615/4040977/09  
material: polycarbonate  
IP56 to EN 60529  
halogen lamp: 12-24V - 35W  
range: 300 m  
light intensity: 90.000cd

**1852062**

type: WISKA - HML-ISO 35 TBL

### Tagsignalscheinwerfer

mit Tasche  
Zulassung: BSH/4615/4040977/09  
IP56 nach EN 60529  
BSH/4615/4040977/09  
Halogenlampe: 12-24V - 35W  
Reichweite: 300m  
Lichtstärke: 90.000 cd

Typ: WISKA - HML-ISO 35 TBL



### Searchlight

2000W - 230V  
inclusive:  
- Bulb  
- Heizung 400W  
- remote control type EF-s

**1852270**

type: Seematz - EFS 463 - HGS

### Suchscheinwerfer

2000W - 230V  
inklusive:  
- Glühlampe  
- Heizung 400W  
- elektrischer Bedienung Typ EF-s

Typ: Seematz - EFS 463 - HGS



Search Lights  
*Scheinwerfer*



**Daylight Signalling Light**  
with battery, charger  
3 halogen lamps 12 V  
in carrying bag

**Tagessignalscheinwerfer**  
mit Akku, Ladegerät  
3 Stck Halogenleuchten 12 V  
mit Tasche

**3311100**

type: NHS200H - 12 Volt - complete *Typ: NHS200H - 12 Volt - komplett*

**3311120**

type: NHS200H - 24 Volt - complete *Typ: NHS200H - 24 Volt - komplett*

Helmet Lights  
*Helmleuchten*



**LED Head Lamp**  
luminous intensity: 24/21/4 Stunden  
incl. 2 x AA/LR06 batteries  
Ex-protected after ATEX. Ex II 3GD  
gases: Ex nAnL IIB T4 (zone 2)  
types of dust: Ex tD A22 IP64 T135°  
C (zone 22)

**LED - Kopfleuchte**  
Lichtstärke: 35/45/60 Lumen  
inkl. 2 x AA/LR06 Batterien  
Batterien und Stirnband.  
Ex.geschützt nach ATEX.  
Ex II 3GD  
Gase: Ex nAn

**1852982**

type: PIXA 3 - E78CHB

*Typ: PIXA 3 - E78CHB*

Other Lamps  
*Sonstige Lampen*



**Testlamp for UV-, IR  
Flammdetectors**  
test range UV flame detectors  
up to 8m in continue mode  
up to 4m in pulse mode

**Testlampe für UV-, IR  
Flammdetektoren**  
Testbereich UV Flammdetektor  
bis 8m im Dauermodus  
bis 4m im Impulsmodus

test range IR UV/IR flame detector  
up to 4m

*Testbereich IR and UV/IR Detektor  
bis 4m*

**1124915**

type: T-229/4P battery operated

*Typ: T-229/4P - Batteriebetrieb*



Glue  
*Kleber*

**Screw Security**  
middle strength - 50 ml

**1100323**

type: WEICONLOCK AN 302-43

**Schraubensicherung**  
*Mittelfest - 50 ml*

Typ: WEICONLOCK AN 302-43

**Screw Security**  
high strength - 50 ml

**1100324**

type: WEICONLOCK AN 302-70

**Schraubensicherung**  
*Hochfest - 50 ml*

Typ: WEICONLOCK AN 302-70

**Epoxy Resin Putty**

**1110010**

type: WEICON - 400 Gramm

**Epoxyharz Kitt**

Typ: WEICON - 400 Gramm

Shackle / Carabiner  
*Schäkel / Karabiner*

**Shackle**  
galvanized steel

**1112290**

8mm - welded - DIN 82101

**Schäkel**  
*galvanisch verzinkt*

8mm - geschweißt - DIN 82101

**Shackle**  
stainless steel

**1112310**

8mm - straight

**Schäkel**  
*Edelstahl*

8mm - gerade

Shackle / Carabiner  
Schäkel / Karabiner



**Snap Hook**  
galvanized steel  
**1892410**  
12 x 140mm

**Karabinerhaken**  
verzinkt  
  
12 x 140mm



**Snap Hook**  
aluminium  
**1892500**  
type: MAS 5290 - screwable

**Karabinerhaken**  
Aluminium  
  
Typ: MAS 5290 - schraubbar

Batteries  
Batterien



**Battery**  
Mignoncell  
**1446400**  
1,5 Volt - type: LR-06/UM-3/AA

**Batterie**  
Mignonzelle  
  
1,5 Volt - Typ: LR-06/UM-3/AA



**Battery**  
Monocell  
**1446600**  
1,5 Volt - type: UM-1/LR-20

**Batterie**  
Monozelle  
  
1,5 Volt - Typ: UM-1/LR-20



**Battery**  
Microcell  
**1446800**  
1,5 Volt - type: LR-03/UM-4/AAA

**Batterie**  
Mikrozelle  
  
1,5 Volt - Typ: LR-03/UM-4/AAA



Batteries  
*Batterien*

**Battery**  
Baby

1932800

1,5 Volt - type: LR-14/UM-2/C

**Batterie**  
Baby

1,5 Volt - Typ: LR-14/UM-2/C

Nets / Leaders / Leads  
*Netze / Leitern / Lote*



**Gangway Net**  
inclusive cords

1127300

8 x 3m

**Gangwaynetz**  
inklusive Halteseile

8 x 3m



**Helicopter Transfer Net**  
inclusive Certificate

1127320

type: Net-X-871 - 4 Person

**Hubschrauber Transfernetz**  
inklusive Zertifikat

Typ: Net-X-871 - 4 Personen



**Access Ladder**  
5 wooden steps / 1 metal step  
for lifeboat with heavy step

1412000

L = 3,5m

**Einsteigeleiter**  
5 Stufen Holz / 1 Stufe Metall  
für Rettungsboot mit schwerer Stufe

L = 3,5m

Nets / Leaders / Leads  
Netze / Leitern / Lote



**Embarkation Ladder**  
hard wooden steps  
DIN ISO 5489 - ressed execution

**1412040**

l = 8,0m

**1412100**

l = 6,5m

**1412120**

l = 14,0m

**Einbootungsleiter**  
Hartholzstufen  
DIN ISO 5489

L = 8,0m

L = 6,5m

L = 14,0m



**Pilot Ladder**  
4 rubber steps  
DIN ISO 799

**1412250**

l = 6,0m

**1412350**

l = 10,2m

**Lotsenleiter**  
4 Gummistufen  
DIN ISO 799

L = 6,0m

L = 10,2m



**Handlead**  
marked

**1570400**

22m - 3kg

**1570500**

40m - 5kg

**1570800**

45m - 8kg

**1570900**

65m - 12,7kg

**Handlot**  
markiert

22m - 3kg

40m - 5kg

45m - 8kg

65m - 12,7kg

Fender / Ropes  
Fender / Taue



**Ball Type Fender - A3**  
red - inflatable

**1525482**

diameter: 62cm - PVC

**1528480**

diameter: 74cm - PVC

**1528481**

diameter: 85cm - PVC

**Kugelfender - A3**  
rot - aufblasbar

Durchmesser: 62cm - PVC

Durchmesser: 74cm - PVC

Durchmesser: 85cm - PVC



Fender / Ropes  
*Fender / Taue*

**Ball Type Fender**

**1528400**

diameter: 40cm - cocos

**1528450**

diameter: 45cm - cocos

**1528500**

diameter: 36cm - cocos

**Kugelfender**

*Durchmesser: 40cm - Kokos*

*Durchmesser: 45cm - Kokos*

*Durchmesser: 36cm - Kokos*



**Manila Rope**  
yardware

**1528540**

diameter: 16mm

**1528550**

diameter: 10mm

**Manilaleine**  
Meterware

*Durchmesser: 16mm*

*Durchmesser: 10mm*



Boathooks  
*Bootshaken*

**Boat Hook**  
aluminium - floating

**1411000**

l = 3,0m

**3834010**

l = 5,0m

**3834011**

l = 6,0m

**Bootshaken**

*Aluminium - schwimmend*

*L = 3,0m*

*L = 5,0m*

*L = 6,0m*

Others  
*Sonstiges*

**Wiping Rags**

**1100200**

package a 25 kg

**Putzlappen**

*Packet a 25 kg*





Others  
Sonstiges



**Penetrating Oil**  
400ml

**1100320**

type: WEICON W44T

**Kriechöl**  
400ml

Typ: WEICON W44T



**Cleaning Spray**  
500ml

**1100321**

type: WEICON S

**Sprühreiniger**  
500ml

Typ: WEICON S



**Compressed-Air Spray**

**1100322**

type: WEICON - 400ml

**Druckluft-Spray**

Typ: WEICON - 400 ml



**Elephant Skin**

**1101050**

80cm x 30m

**Elefantenhaut**

80cm x 30m



**Paper Bin**  
steel painted

**1101410**

15 litre - selfextinguishing

**Papierkorb**  
Stahl lackiert

15 Liter - mit Löschkopf



**Silicone**  
transparency

**1110800**

300ml - cartouche

**Silikon**  
transparent

300 ml - Kartusche



**Bucket - Edificial**  
plastic

**1320800**

12 litre

**Baueimer**  
Kunststoff

12 Liter



Others  
Sonstiges

**Vaseline**

1413920

1000ml - in tin

**Vaseline**

1000ml - in Dose



**Rat Trap**

1532400

**Rattenfalle**



**Funnel**  
plastic

1533000

10cm

1533100

15cm

1533300

20cm

**Trichter**  
Kunststoff

10cm

15cm

20cm



**Seal Set**

1784800

50 pieces / 10m wire

**Plomben - Satz**

50 Stück / 10m Draht



**Lead Seal Tong**

1784900

size 8

**Plombierzange**

Größe 8



**Rescue Shears**  
inclusive bracket  
24 x 11cm

1784910

type: Robin Safety

**Rettungsschere**  
inklusive Halter  
24 x 11cm

Typ: Robin Safety



**Leak Detector**  
for refrigerants  
21,59 x 8,26 x 5cm  
refrigerant FCKW/HFCKW

1820850

type: ROBINAIR 16600

**Lecksuchgerät**  
für Kältemittel  
21,59 x 8,26 x 5cm  
Kältemittel FCKW/HFCKW

Typ: ROBINAIR 16600

Others  
Sonstiges



**Lubricant Spray**  
300ml

**1824000**

with teflon

**Gleitspray**  
Dose 300ml

mit Teflon



**Electrical Blanket**  
according to VDE 0680/1

**1842300**

1000 Volt - 100 x 100cm

**Elektrodecke**  
nach VDE 0680/1

1000 Volt - 100 x 100cm



**Shore Leave Bord**  
with Signing and ships name

**1893300**

65 x 50cm

**Landgangstafel**  
mit Beschilderung und Schiffname

65 x 50cm



**Frame**  
for musterlist  
aluminium

**1895700**

640 x 470mm

**1895750**

1189 x 841mm

**Rahmen**  
für Sicherheitsrolle  
Aluminium

640 x 470mm

1189 x 841mm



**Musterlist**  
German / English  
SOLAS

**1895800**

42 x 80 x 62,3cm

**Sicherheitsrolle**  
Deutsch / Englisch  
SOLAS

42 x 80 x 62,3cm



**Station Card**  
50 pieces / package

**1895900**

125 x 75mm

**Rollenkarten**  
50 Stück / Paket

125 x 75mm



Others  
*Sonstiges*

**Station Card Holder**  
chrome plated

**1895910**

125 x 75mm

**Rollenkartenhalter**  
verchromt

125 x 75mm

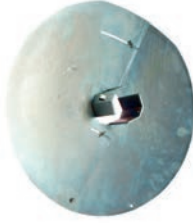

**Rat Guard**  
adjustable 50 - 100mm  
complete mounted  
galvanized steel

**3813200**

diameter: 600mm

**Rattenblech**  
verstellbar von 50-100mm  
komplett montiert  
Stahl verzinkt

Durchmesser: 600mm



**Visitors Log Book**

1102120

**Besucher Logbuch**



**Manual**  
english

1447200

"Lifeboat Survival Manual"

**Handbuch**  
Englisch

"Lifeboat Survival Manual"



**Manual**  
english

1447202

"Liferaft Survival Manual"

**Handbuch**  
Englisch

"Rettungsfluss - Überlebenshandbuch"



**Manual**

1447460

"Search and Rescue"

**Handbuch**

"Suche und Rettung"



**Manual**

1447470

"Guidelines and Bulletin"

**Handbuch**

"Richtlinien und Merkblätter"



**Manual**  
German language

1447480

"COLREG - 1972"

**Handbuch**  
Deutsche Ausgabe

"COLREG - 1972"



**Manual**  
LSA-Code

1447490

"Life Saving Appliances"

**Handbuch**  
LSA-Code

"Life Saving Appliances"



**Manual**

1447510

"GMDSS Handbook"

**Handbuch**

"GMDSS Handbook"



**Manual**

1447530

"Fire Safety Operations"

**Handbuch**

"Fire Safety Operations"



**Manual**

1447532

"Chronometer Rate Book"

**Handbuch**

"Chronometer Tagebuch"



**Manual**

1447533

"Training manual - Life saving appliances"

**Handbuch**

"Training manual - Life saving appliances"



Deckwash hoses  
*Deckwaschschläuche*



**Deckwash Hose**  
rubber - without coupling

**1528000**

15m - 38 x 7mm - conical type

**1528100**

25m - 38 x 7mm - conical type

**1528300**

20 m - 38 x 7mm - conical type

**Deckwaschschlauch**  
Gummi - ohne Kupplung

15m - 38 x 7mm - konisch zulaufend

25m - 38 x 7mm - konisch zulaufend

20m - 38 x 7mm - konisch zulaufend

Hose clips  
*Schlauchschellen*



**Hose Clip**  
stainless steel

**1572910**

clamping range: 20-32mm

**1872140**

clamping range: 25-40mm

**1872150**

clamping range: 16-27mm

**1872160**

clamping range: 40-60mm

**1872170**

clamping range: 23-35mm

**1872180**

clamping range: 50-70mm

**1872190**

clamping range: 32-50mm

**Schlauchschelle**  
Edelstahl

Spannbereich: 20-32mm

Spannbereich: 25-40mm

Spannbereich: 16-27mm

Spannbereich: 40-60mm

Spannbereich: 23-35mm

Spannbereich: 50-70mm

Spannbereich: 32-50mm



**Hose Clip**  
galvanized steel

**1872200**

clamping range: 40-60mm

**1872210**

clamping range: 16-27mm

**1872220**

clamping range: 20-32mm

**1872240**

clamping range: 32-50mm

**1872300**

clamping range: 50-70mm

**1872400**

clamping range: 25-40mm

**Schlauchschelle**  
Stahl verzinkt

Spannbereich: 40-60mm

Spannbereich: 16-27mm

Spannbereich: 20-32mm

Spannbereich: 32-50mm

Spannbereich: 50-70mm

Spannbereich: 25-40mm



Signage

*Beschilderung*

NO



A photograph of a wooden pier railing overlooking the ocean. The railing consists of a dark brown metal beam with the word "FISHING" painted in white, bold, capital letters. Below this is a weathered wooden beam with a circular hole and a metal fastener. The background shows the blue ocean with white waves and a sandy beach in the distance. A solid olive-green rectangular block is positioned in the upper right corner of the image.

**FISHING**

### Galley Sign



### Galley Sign



### ISPS Code Sign















































IMO Symbol

















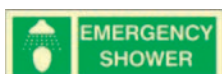







<b>M160002</b>	<b>M100160</b>	<b>M152160</b>	<b>M100260</b>	<b>M152260</b>	<b>M150160</b>	<b>M330160</b>	<b>M150260</b>	<b>M150360</b>	<b>M150460</b>
150x150mm	100x100mm	150x150mm	100x100mm	150x150mm	150x150mm	300x300mm	150x150mm	150x150mm	150x150mm
<b>M150560</b>	<b>M150660</b>	<b>M150760</b>	<b>M150860</b>	<b>M150960</b>	<b>M151060</b>	<b>M151160</b>	<b>M501160</b>	<b>M151260</b>	<b>M151360</b>
150x150mm	150x150mm	150x150mm	150x150mm	150x150mm	150x150mm	150x150mm	50x50mm	150x150mm	150x150mm
<b>M151460</b>	<b>M151560</b>	<b>M151660</b>	<b>M151760</b>	<b>M151860</b>	<b>M151960</b>	<b>M152060</b>	<b>M332060</b>	<b>M152360</b>	<b>M152460</b>
150x150mm	150x150mm	150x150mm	150x150mm	150x150mm	150x150mm	150x150mm	300x300 - self adhesive	150x150mm	150x150mm
<b>M152560</b>	<b>M152660</b>	<b>M152760</b>	<b>M152860</b>	<b>M152960</b>	<b>M153060</b>	<b>M154160</b>	<b>M154360</b>	<b>M154460</b>	<b>M154560</b>
150x150mm	150x150mm	150x150mm	150x150mm	150x150mm	150x150mm	150x150mm	150x150mm	150x150mm	150x150mm
			<b>EMERGENCY EXIT</b>		<b>EXIT</b>	<b>VOYAGE DATA RECORDER</b>			
<b>M154760</b>	<b>M154860</b>	<b>M154960</b>	<b>M155060</b>	<b>M155660</b>	<b>M155860</b>	<b>M156360</b>	<b>M156460</b>	<b>M156560</b>	<b>M156660</b>
150x150mm	150x150mm	150x150mm	150x150mm	150x150mm	150x150mm	150x150mm	150x150mm	150x150mm	150x150mm
	<b>SAFETY LOCKER</b>								
<b>M156860</b>	<b>M156960</b>	<b>T150160</b>	<b>T330160</b>	<b>T150260</b>	<b>T150360</b>	<b>T150460</b>	<b>T150560</b>	<b>T150660</b>	<b>T150760</b>
150x150mm	150x150mm	150x150mm	300x300mm	150x150mm	150x150mm	150x150mm	150x150mm	150x150mm	150x150mm
<b>T150860</b>	<b>T150960</b>	<b>T151060</b>	<b>T151160</b>	<b>T151260</b>	<b>T151360</b>	<b>T151460</b>	<b>T151560</b>	<b>T151660</b>	<b>T151760</b>
150x150mm	150x150mm	150x150mm	150x150mm	150x150mm	150x150mm	150x150mm	150x150mm	150x150mm	150x150 - with text
<b>T151860</b>	<b>T151960</b>	<b>T152060</b>	<b>T332060</b>	<b>T152460</b>	<b>T152960</b>	<b>T154460</b>	<b>T154560</b>	<b>T154860</b>	<b>T154960</b>
150x150mm	150x150mm	150x150mm	300x300mm	150x150mm	150x150mm	150x150mm	150x150mm	150x150mm	150x150mm
<b>T155660</b>	<b>T156260</b>	<b>T156360</b>	<b>T156460</b>	<b>T156560</b>					
150x150mm	150x150mm	150x150mm	150x150mm	150x200mm - with text					



IMO Symbol

									
M155160 150x300mm	M155460 75x150mm	M305460 150x300mm	M155760 150x300mm	M155960 150x300mm	M156060 150x300mm				
									
M156160 150x300mm	M156760 150x300mm	M158160 75x150mm	M308160 150x300mm	M158260 75x150mm	M308260 150x300mm	M158360 75x150mm	M308360 150x300mm		
									
M158460 75x150mm	M308460 150x300mm	M158560 75x150mm	M308560 150x300mm	M158660 75x150mm	M308660 150x300mm	M158760 75x150mm	M308760 150x300mm	M158860 75x150mm	M308860 150x300mm
									
M158960 75x150mm	M308960 150x300mm	M159060 75x150mm	M309060 150x300mm	M159160 75x150mm	M309160 150x300mm	M159260 75x150mm	M309260 150x300mm	M159360 75x150mm	M309360 150x300mm
									
M159460 75x150mm	M309460 150x300mm	M159560 75x150mm	M309560 150x300mm	M159660 75x150mm	M309660 150x300mm	M159760 75x150mm	M309760 150x300mm	M159860 75x150mm	M309860 150x300mm

IMO Symbol

				
M300160 100x300mm	M300260 100x300mm	M300360 100x300mm	M300460 100x300mm	M300560 100x300mm
				
M300660 100x300mm	M450660 150x400mm	M300860 100x300mm	M300960 100x300mm	M450960 150x400mm
				
M301060 100x300mm	M301160 100x300mm	M451160 150x400mm	M301260 100x300mm	M451260 150x400mm
				
M301360 100x300mm	M451360 150x400mm	M301460 100x300mm	M451460 150x400mm	M301560 100x300mm
				
M451560 150x400mm	M301660 100x300mm	M301760 100x300mm	M301860 100x300mm	M301960 100x300mm



IMO Symbol

 M451960 150x400mm	 M302060 100x300mm	 M452060 150x400mm	 M302160 100x300mm	 M452160 150x400mm
 M302260 100x300mm	 M302360 100x300mm	 M302460 100x300mm	 M302560 100x300mm	
 M302660 100x300mm		 M302760 100x300mm		 M302860 100x300mm
 M400160 150x400mm	 M400260 150x400mm	 M400360 150x400mm	 M400460 150x400mm	 M400560 150x400mm
 M400660 150x400mm	 M400760 150x400mm	 M400860 150x400mm	 M400960 150x400mm	 M401060 150x400mm
 M401160 150x400mm	 M401260 150x400mm	 M401360 150x400mm	 M401460 150x400mm	 M401760 150x400mm
 M401860 150x400mm	 M401960 150x400mm	 M402060 150x400mm	 S300160 100x300mm	 S300260 100x300mm
 S300360 100x300mm	 S300460 100x300mm	 S300560 100x300mm	 S300660 100x300mm	 S300760 100x300mm
 S300860 100x300mm	 S300960 100x300mm	 S301060 100x300mm	 S301160 100x300mm	 S301260 100x300mm
 S301360 100x300mm	 S301460 100x300mm	 S301560 100x300mm	 S301660 100x300mm	 S301760 100x300mm
 S301860 100x300mm	 S301960 100x300mm	 S302060 100x300mm	 S302160 100x300mm	 S302260 100x300mm
 S302360 100x300mm	 S302460 100x300mm	 S302560 100x300mm		

IMO Symbol

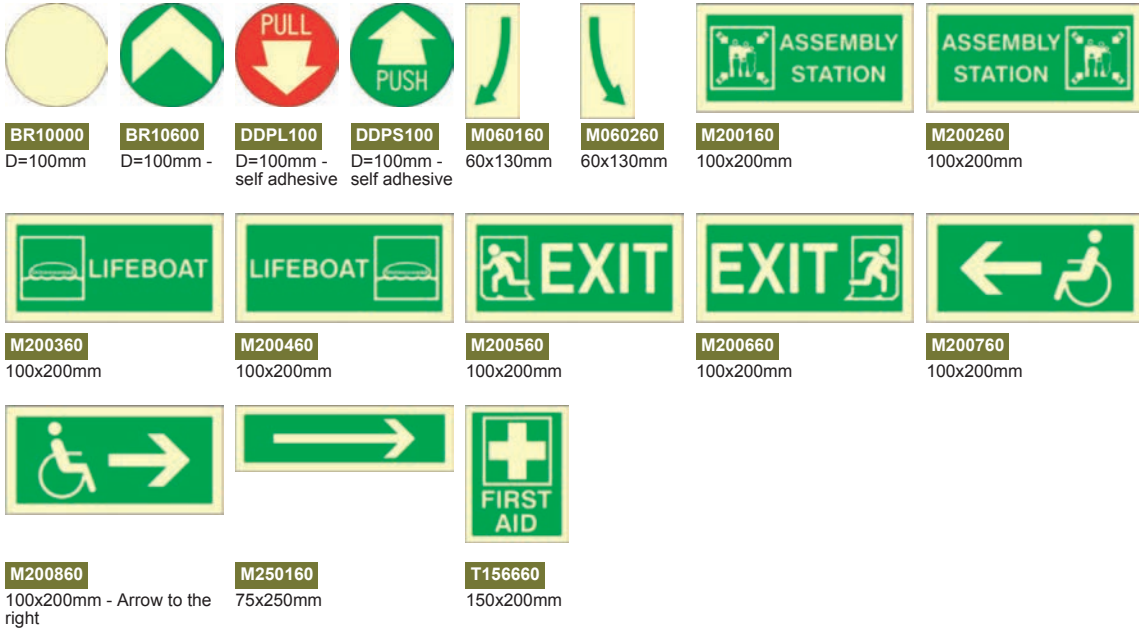

























Panoramic Fire Sign





Panoramic Fire Sign



Panoramic Fire Sign

 <b>M300130</b> 100x300mm	 <b>M300230</b> 100x300mm	 <b>M300330</b> 100x300mm	 <b>M300430</b> 100x300mm	 <b>M300530</b> 100x300mm
 <b>M300630</b> 100x300mm	 <b>M300730</b> 100x300mm	 <b>M300830</b> 100x300mm	 <b>M300930</b> 100x300mm	 <b>M301030</b> 100x300mm
 <b>M301130</b> 100x300mm	 <b>M301230</b> 100x300mm	 <b>M301330</b> 100x300mm	 <b>M301430</b> 100x300mm	 <b>M301530</b> 100x300mm
 <b>M301630</b> 100x300mm	 <b>M301730</b> 100x300mm	 <b>M301830</b> 100x300mm	 <b>M301930</b> 100x300mm	 <b>M302030</b> 100x300mm
 <b>M302130</b> 100x300mm	 <b>M302230</b> 100x300mm	 <b>M302330</b> 100x300mm	 <b>M302430</b> 100x300mm	

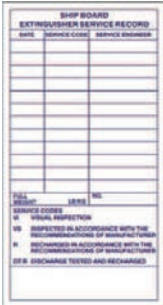
Panoramic Fire Sign

 <b>F800150</b> 80x150mm	 <b>M100130</b> 100x200mm	 <b>M100230</b> 100x200mm	 <b>M100330</b> 100x200mm	 <b>M100430</b> 100x200
 <b>M100530</b> 100x200mm				

Fire Control Symbol

M150190 150x150mm	M150290 150x150mm	M150390 150x150mm	M150490 150x150mm	M150590 150x150mm	M150690 150x150mm	M150790 150x150mm	M150890 150x150mm	M150990 150x150mm	M151090 150x150mm
M151190 150x150mm	M151290 150x150mm	M151390 150x150mm	M151490 150x150mm	M151590 150x150mm	M151690 150x150mm	M151790 150x150mm	M151890 150x150mm	M151990 150x150mm	M152090 150x150mm
M152190 150x150mm	M152290 150x150mm	M152390 150x150mm	M152490 150x150mm	M152590 150x150mm	M152690 150x150mm	M152790 150x150mm	M152890 150x150mm	M152990 150x150mm	M153090 150x150mm
M153190 150x150mm	M153290 150x150mm	M153390 150x150mm	M153490 150x150mm	M153590 150x150mm	M153690 150x150mm	M153790 150x150mm	M153890 150x150mm	M153990 150x150mm	M154090 150x150mm
M154190 150x150mm	M154290 150x150mm	M154390 150x150mm	M154490 150x150mm	M154590 150x150mm	M154690 150x150mm	M154790 150x150mm	M154890 150x150mm	M154990 150x150mm	M155090 150x150mm
M155190 150x150mm	M155290 150x150mm	M155390 150x150mm	M155490 150x150mm	M155560 150x150mm	M155590 150x150mm	M155690 150x150mm	M155790 150x150mm	M155890 150x150mm	M155891 150x150mm
M335890 300x300mm	M155990 150x150mm	M156090 150x150mm	M156190 150x150mm	M156290 150x150mm	M156390 150x150mm	M156490 150x150mm	M156590 150x150mm	M156690 150x150mm	M156790 150x150mm
M156890 150x150mm	M156990 150x150mm	M157090 150x150mm	M157190 150x150mm	M157290 150x150mm	M157390 150x150mm	M157490 150x150mm	M157590 150x150mm	M157690 150x150mm	M157790 150x150mm
M157890 150x150mm	M157990 150x150mm	M158090 150x150mm	M158290 150x150mm	M158390 150x150mm	M158490 150x150mm	M158590 150x150mm	M158690 150x150mm	M158790 150x150mm	M158890 150x150mm



Fire Control Symbol

M158990	M159090	M159190	M159290	M159390	M159490	M159590	M159690
150x150mm	150x150mm	150x150mm	150x150mm	150x150mm	150x150mm	150x150mm	150x150mm

Fire Control Symbol

M1505S0	M1507C0	M1507F0	M1507H0	M1507P0	M1507S0	M1507W0	M1509C0	M1509F0	M1509H0
150x150mm	150x150mm	150x150mm	150x150mm	150x150mm	150x150mm	150x150mm	150x150mm	150x150mm	150x150mm
M1509N0	M1509P0	M1509W0	M1510C0	M1510F0	M1510H0	M1510N0	M1510P0	M1510W0	M1514F0
150x150mm	150x150mm	150x150mm	150x150mm	150x150mm	150x150mm	150x150mm	150x150mm	150x150mm	150x150mm
M1514P0	M1514W0	M1517F0	M1517P0	M1517S0	M1517W0	M1520A0	M1520B0	M1520C0	M1520D0
150x150mm	150x150mm	150x150mm	150x150mm	150x150mm	150x150mm	150x150mm	150x150mm	150x150mm	150x150mm
M1520E0	M1520F0	M1520G0	M1520H0	M1520J0	M1520K0	M1520L0	M1520M0	M1524W0	M1536F0
150x150mm	150x150mm	150x150mm	150x150mm	150x150mm	150x150mm	150x150mm	150x150mm	150x150mm	150x150mm
M1550C0	M1550F0	M1550H0	M1550N0	M1550P0	M1550W0	M1555S0	M1557W0	M1563A0	M1563C0
150x150mm	150x150mm	150x150mm	150x150mm	150x150mm	150x150mm	150x150mm	150x150mm	150x150mm	150x150mm
M1563M0	M1565H0	M1565S0	M1565W0	M1567S0	M1572A0	M1572C0	M1572M0	M1574F0	M1575C0
150x150mm	150x150mm	150x150mm	150x150mm	150x150mm	150x150mm	150x150mm	150x150mm	150x150mm	150x150mm
M1575F0	M1575H0	M1575N0	M1575P0	M1575W0	M1578A0	M1578C0	M1578F0	M1578M0	M1578W0
150x150mm	150x150mm	150x150mm	150x150mm	150x150mm	150x150mm	150x150mm	150x150mm	150x150mm	150x150mm

Fire Control Symbol

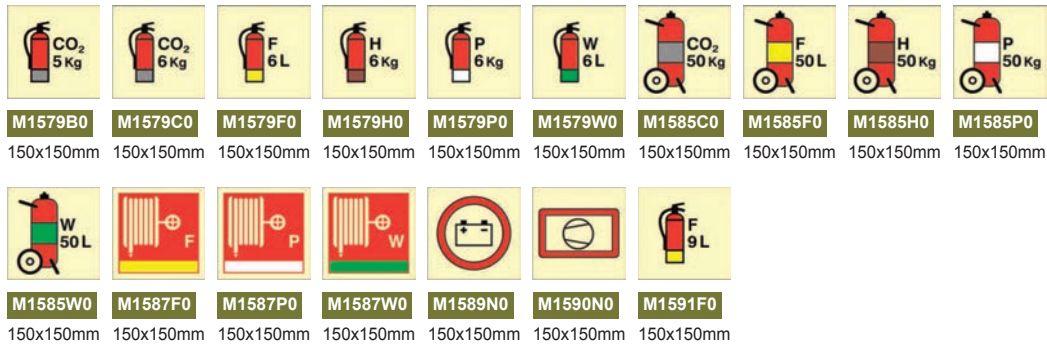

Mandatory Sign

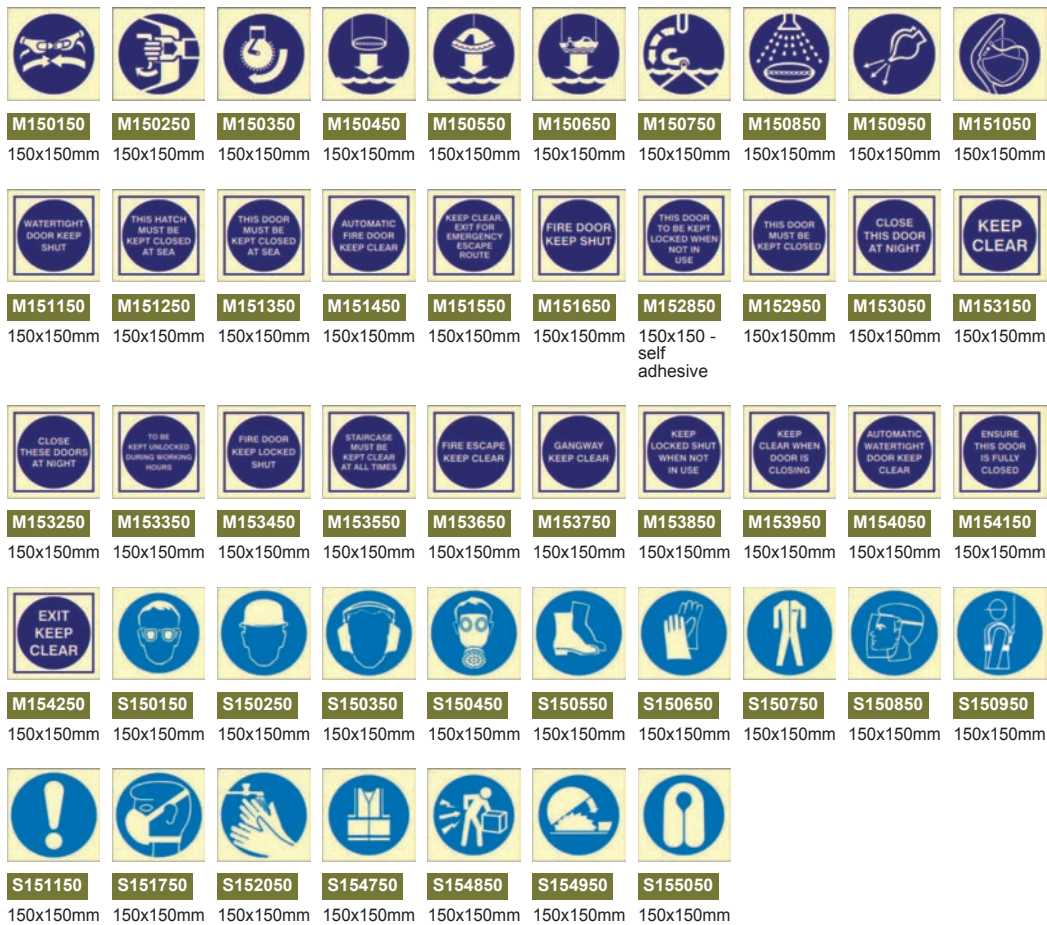



## Mandatory Sign



## Mandatory Sign

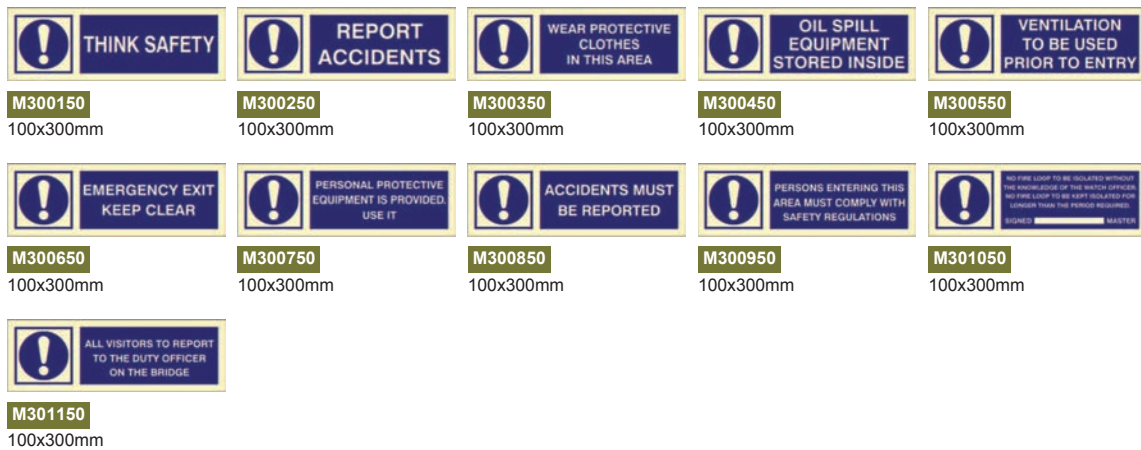

## Mandatory Sign



Mandatory Sign

									
<b>S200150</b> D=200mm - foil	<b>S200250</b> D=200mm - foil	<b>S200350</b> D=200mm - foil	<b>S200450</b> D=200mm - foil	<b>S200550</b> D=200mm - foil	<b>S200650</b> D=200mm - foil	<b>S200750</b> D=200mm - foil	<b>S200850</b> D=200mm - foil	<b>S200950</b> D=200mm - foil	<b>S201150</b> D=200mm - foil
									
<b>S201250</b> D=200mm - foil	<b>S201650</b> D=200mm - foil	<b>S201750</b> D=200mm - foil	<b>S202050</b> D=200mm - foil	<b>S202250</b> D=200mm - foil	<b>S202350</b> D=200mm - foil	<b>S202750</b> D=200mm - foil	<b>S202950</b> D=200mm - foil	<b>S203150</b> D=200mm - foil	<b>S203250</b> D=200mm - foil

Hazard Sign

H150110	H150210	H150310	H150410	H150510	H150610	H150710	H150810	H150910	H151010
150x200mm	150x200mm	150x200mm	150x200mm	150x200mm	150x200mm	150x200mm	150x200mm	150x200mm	150x200mm
H151110	H151210	H151310	H151410	H151510	H151610	H151710	H151810	H151910	H152010
150x200mm	150x200mm	150x200mm	150x200mm	150x200mm	150x200mm	150x200mm	150x200mm	150x200mm	150x200mm
H152110	H152210	H152310	H152410	H152510	H152610	H152710	H152810	H152910	H153010
150x200mm	150x200mm	150x200mm	150x200mm	150x200mm	150x200mm	150x200mm	150x200mm	150x200mm	150x200mm
H153110	H153210	H153310	H153410	H153510	H153610	H153710	H153810	H153910	H154010
150x200mm	150x200mm	150x200mm	150x200mm	150x200mm	150x200mm	150x200mm	150x200mm	150x200mm	150x200mm
H154110	H154210	H154310	H154510	H154610	H154710	H154810	H154910	H155010	H155110
150x200mm	150x200mm	150x200mm	150x200mm	150x200mm	150x200mm	150x200mm	150x200mm	150x200mm	150x200mm
H155210	H155310	H155410	H155510	H155710	H155810	H155910	H156010	H156110	H156210
150x200mm	150x200mm	150x200mm	150x200mm	150x200mm	150x200mm	150x200mm	150x200mm	150x200mm	150x200mm
H156410	H156510	H156610	H156710	H156810	H156910	H157010	H157210	S150110	S150210
150x200mm	150x200mm	150x200mm	150x200mm	150x200mm	150x200mm	150x200mm	150x200mm	150x150mm	150x150mm
S150310	S150410	S150510	S150710	S150810	S150910	S151210	S151410	S152810	S153410
150x150mm	150x150mm	150x150mm	150x150mm	150x150mm	150x150mm	150x150mm	150x150mm	150x150mm	150x150mm

Hazard Sign

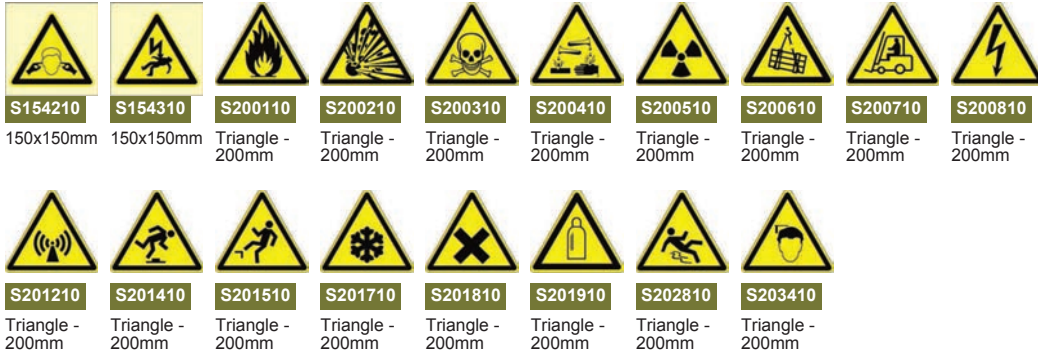

IMDG Label

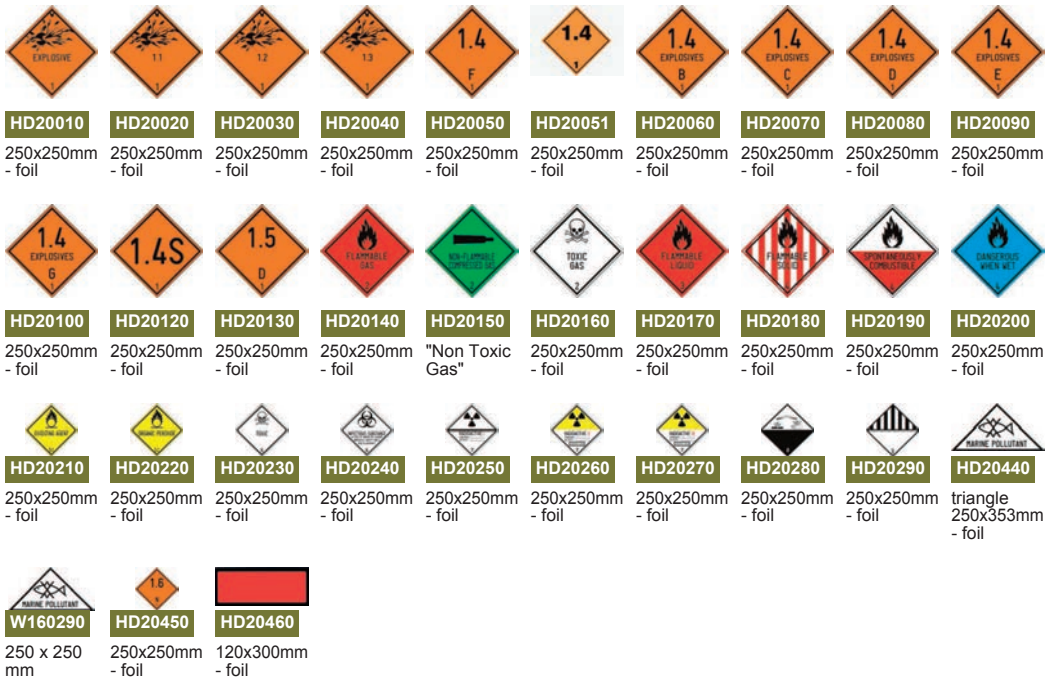



Prohibition Sign



Prohibition Sign



Prohibition Sign



Prohibition Sign



Combination Sign





## Combination Sign

<p><b>KF34230</b> 300x400mm</p>	<p><b>KF34240</b> 300x400mm</p>	<p><b>KF34250</b> 300x400mm</p>	<p><b>KF34260</b> 300x400mm</p>	<p><b>KF34270</b> 300x400mm</p>
<p><b>KF34280</b> 300x400mm</p>	<p><b>KF34290</b> 300x400mm</p>	<p><b>KF34300</b> 300x400mm</p>	<p><b>KF34310</b> 300x400mm</p>	<p><b>KF34320</b> 300x400mm</p>
<p><b>KF343010</b> 300x400mm</p>	<p><b>KF343020</b> 300x400mm</p>	<p><b>KF343030</b> 300x400mm</p>		















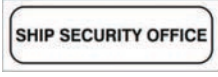







## Combination Sign

<p><b>KF34170</b> 400x600mm</p>	<p><b>KF34180</b> 400x600mm</p>
-------------------------------------	-------------------------------------

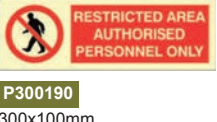
## ISPS Code Sign

<p><b>ISPS010</b> 200x300mm</p>	<p><b>ISPS020</b> 297x420mm</p>	<p><b>ISPS030</b> 420x594mm</p>	<p><b>ISPS040</b> Numbers 1-30</p>	<p><b>ISPS050</b> 210x297mm</p>
<p><b>ISPS060</b> 148x210mm</p>	<p><b>ISPS070</b> 210x297mm</p>	<p><b>ISPS080</b> 210x297mm</p>	<p><b>ISPS090</b> 300x350mm</p>	<p><b>ISPS100</b> 250x500mm</p>

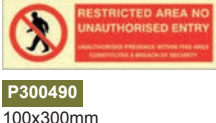
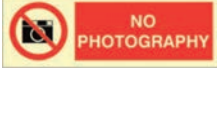
ISPS Code Sign

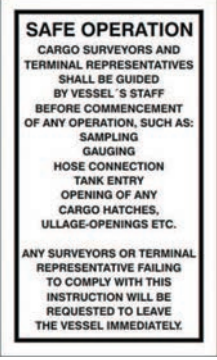
 <b>ISPS110</b> adjustable in 3 levels	 <b>ISPS120</b> 40x300mm	 <b>ISPS130</b> 300x300mm	 <b>ISPS140</b> 300x300mm	 <b>ISPS150</b> 100x300mm
 <b>ISPS160</b> 100x300mm	 <b>ISPS170</b> 100x300mm	 <b>ISPS180</b> 150x150mm	 <b>IT35290</b> 35mm x 20m	 <b>L250190</b> 25x50mm
 <b>L250290</b> 25x50mm	 <b>L250390</b> 25x50mm	 <b>L250490</b> 25x50mm	 <b>P153350</b> 150x150mm	 <b>P153450</b> 150x150mm
 <b>P300150</b> 100x300mm	 <b>P300190</b> 300x100mm	 <b>P300250</b> 100x300mm	 <b>P300290</b> 300x100mm	 <b>P300350</b> 100x300mm
 <b>P300390</b> 100x300mm	 <b>P300490</b> 100x300mm	 <b>P300590</b> 100x300mm	 <b>S114290</b> 42x110mm	 <b>S154830</b> 150x150mm
 <b>W150190</b> 150x250mm				

Passengers Sign

 <b>P150150</b> 150x150mm	 <b>P150250</b> 150x150mm	 <b>P150350</b> 150x150mm	 <b>P150450</b> 150x150mm	 <b>P150550</b> 150x150mm	 <b>P150650</b> 150x150mm	 <b>P150750</b> 150x150mm	 <b>P150850</b> 150x150mm	 <b>P150950</b> 150x150mm	 <b>P151050</b> 150x150mm
 <b>P151150</b> 150x150mm	 <b>P151250</b> 150x150mm	 <b>P151350</b> 150x150mm	 <b>P151450</b> 150x150mm	 <b>P151550</b> 150x150mm	 <b>P151650</b> 150x150mm	 <b>P151750</b> 150x150mm	 <b>P151850</b> 150x150mm	 <b>P151950</b> 150x150mm	 <b>P152050</b> 150x150mm
 <b>P152150</b> 150x150mm	 <b>P152250</b> 150x150mm	 <b>P152350</b> 150x150mm	 <b>P152450</b> 150x150mm	 <b>P152550</b> 150x150mm	 <b>P152650</b> 150x150mm	 <b>P152750</b> 150x150mm	 <b>P152850</b> 150x150mm	 <b>P152950</b> 150x150mm	 <b>P153050</b> 150x150mm

## Passengers Sign



## Training - Safety Poster

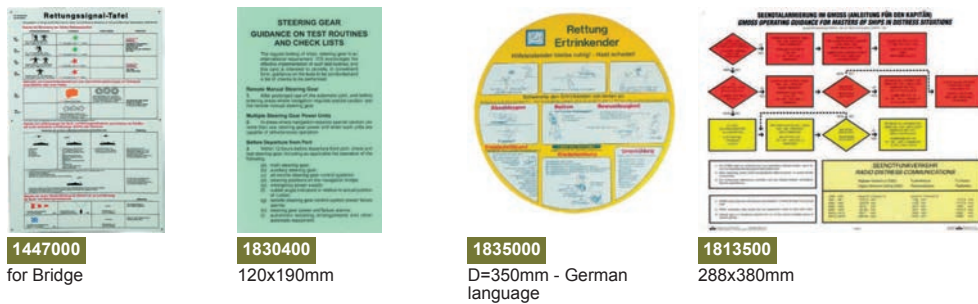

**1835010**  
280x400mm - German language



**1835100**  
210x297mm - German language



**1835200**  
210x297mm - German language



**HSP4010**  
210x297mm - foil



**HSP4020**  
210x297mm - foil



**HSP4030**  
210x297mm - foil

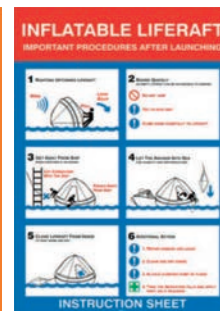

**ISA3010**  
297x420mm - foil



**ISA3020**  
297x420mm - foil





**ISA3030**  
297x420mm - foil



**ISA3040**  
297x420mm - foil



**ISA3050**  
297x420mm - foil



**ISA3060**  
297x420mm - foil



**ISA3070**  
297x420mm - foil



**ISA3080**  
297x420mm - foil



**ISA3090**  
297x420mm - foil



**ISA3100**  
297x420mm - foil



**ISA3110**  
297x420mm - foil

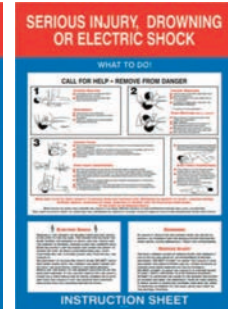

**ISA3120**  
297x420mm - foil



**ISA3130**  
297x420mm - foil



**ISA3140**  
297x420mm - foil



**ISA3150**  
297x420mm - foil



**ISA3160**  
297x420mm - foil

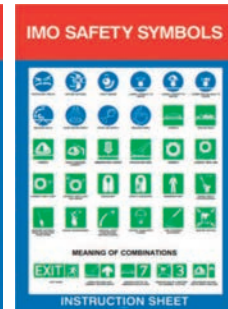

**ISA3170**  
297x420mm - foil



**ISA3180**  
297x420mm - foil



**ISA3190**  
297x420mm - foil



**ISA3200**  
297x420mm - foil

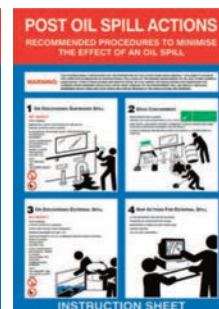

**ISA3210**  
297x420mm - foil

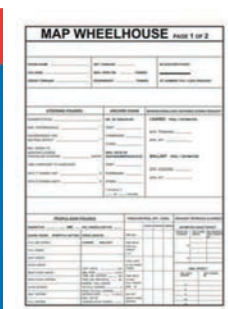

**ISA3230**  
297x420mm - rigid PVC



Training - Safety Poster

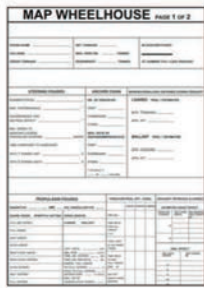

**ISA3240**  
297x420mm - rigid PVC



**ISA3250**  
297x420mm - rigid PVC



**ISA3340**  
297x420mm - foil



**ISA3350**  
297x420mm - foil



**ISA3360**  
297x420mm - foil



**ISA3370**  
297x420mm - foil



**ISA3380**  
297x420mm - foil



**ISA3390**  
297x420mm - foil



**ISA3400**  
297x420mm - foil



**ISA3410**  
297x420mm - foil



**ISA3420**  
297x420mm - foil



**ISA3430**  
297x420mm - foil



**ISA3440**  
297x420mm - foil



**ISA3450**  
297x420mm - foil



**ISA3460**  
297x420mm - foil



**ISA3470**  
297x420mm - foil



**ISA3480**  
297x420mm - foil



**ISA3490**  
297x420mm - foil



**ISA3500**  
297x420mm - foil

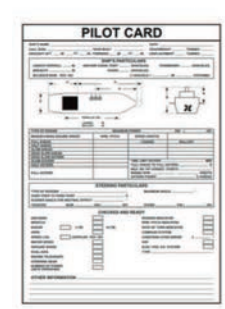

**ISA3520**  
297x420mm - rigid PVC

Signage  
Beschilderung

Poster  
Poster

Training - Safety Poster

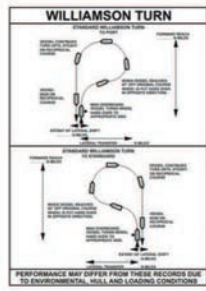

ISA3530  
297x420mm - rigid PVC



ISA3540  
297x420mm - foil - spanish



ISA3600  
297x420mm - foil



ISA4220  
210x297mm - foil



ISA4260  
210x297mm - foil



ISA4270  
210x297mm - foil



ISA4280  
210x297mm - foil



ISA4290  
210x297mm - foil



ISA4300  
210x297mm - foil

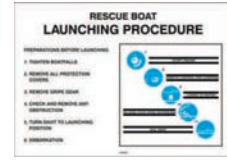

ISA4500  
210x297mm - foil

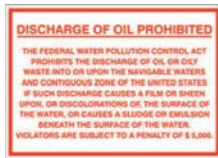

ISA4700  
210x297mm - foil



ISA4710  
210x297mm - foil



ISA5300  
148x210mm - foil



ISA5310  
148x210mm - foil



ISA5320  
210x297mm - foil

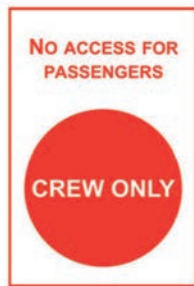

ISA5330  
148x210mm - foil



ISA5340  
148x210mm - foil



ISA5350  
148x210mm - foil



ISA5360  
148x210mm - foil



ISA5370  
148x210mm - foil



ISA5380  
148x210mm



ISA5390  
148x210mm



ISA5400  
148x210mm - foil



Fire / Safety Plan Stickers

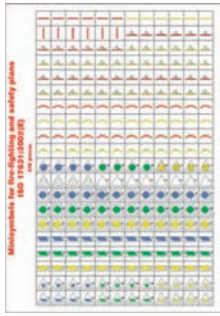

**MS10A10**  
148x210mm - 240 pieces

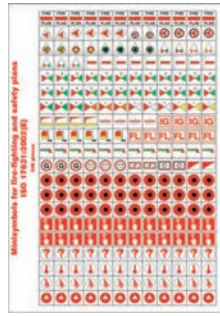

**MS10A20**  
148x210mm - 240 pieces

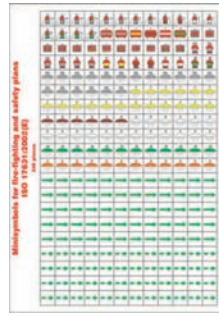

**MS10A30**  
148x210mm - 240 pieces

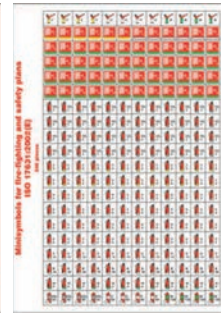

**MS10A40**  
148x210mm - 240 pieces

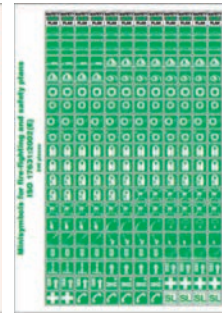

**MS10A50**  
148x210mm - 240 pieces

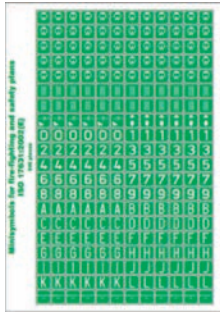

**MS10A60**  
148x210mm - 240 pieces

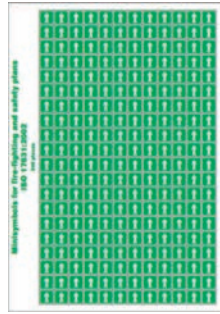

**MS10A80**  
148x210mm - 240 pieces

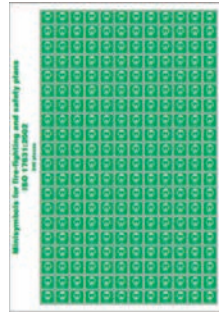

**MS10A90**  
148x210mm - 240 pieces

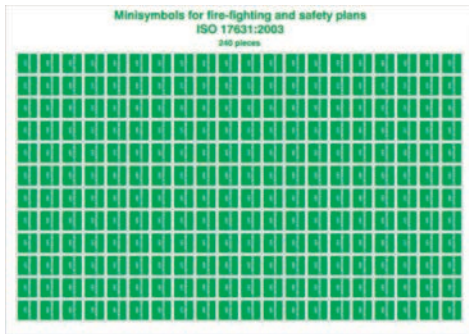

**MS10B10**  
148x210mm - 240 pieces

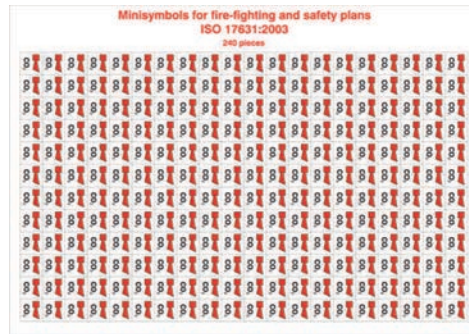

**MS10B20**  
148x210mm - 240 pieces



**MS10B30**  
148x210mm

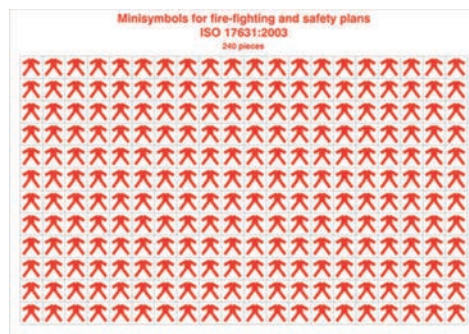

































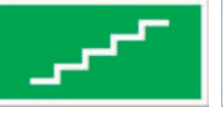
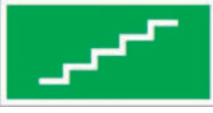
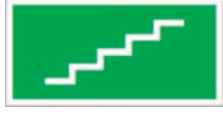
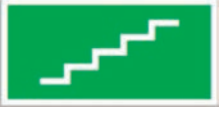
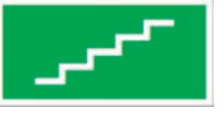
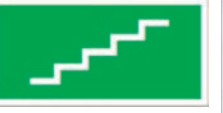

**MS10B40**  
148x210mm - 240 pieces

Signage  
Beschilderung

Mini Symbols  
Mini Symbols

Floor Escape Route

 <b>AT25LS0</b> 25mm x 10m	 <b>AT50LS0</b> 50mm x 10m	 <b>IT02LS0</b> 20mm x 10m	 <b>IT04LS0</b> 40mm x 10m	 <b>IT05LS0</b> 50mm x 10m	 <b>IT04030</b> 40mm x 10m	 <b>IT08030</b> 80mm x 10m
						
<b>IT04060</b> 40mm x 10m	<b>IT08060</b> 80mm x 10m	<b>IT04090</b> 40mm x 10m	<b>IT08090</b> 80mm x 10m	<b>M0841L0</b> 58x29mm - transparent		
						
<b>M1050L0</b> 96x48mm - Antislip	<b>M1261L0</b> 96x48mm - transparent	<b>M1681L0</b> 134x67mm - transparent	<b>M0841R0</b> 58x29mm - transparent	<b>M1050R0</b> 96x48mm - Antislip		
						
<b>M1261R0</b> 96x48mm - transparent	<b>M1681R0</b> 134x67mm	<b>M0842L0</b> 58x29mm - transparent	<b>M1262L0</b> 96x48mm - transparent	<b>M1682L0</b> 134x67mm - transparent		
						
<b>M0842R0</b> 58x29mm - transparent	<b>M1262R0</b> 96x48mm - transparent	<b>M1682R0</b> 134x67mm - transparent	<b>M0843L0</b> 58x29mm - transparent	<b>M0843R0</b> 58x29mm - transparent		
						
<b>M1263L0</b> 96x48mm - transparent	<b>M1263R0</b> 96x48mm - transparent	<b>M1683L0</b> 134x67mm - transparent	<b>M1683R0</b> 134x67mm - transparent	<b>M4124L0</b> 29x87mm - transparent	<b>M6184L0</b> 96x48mm - transparent	
						
<b>M8244L0</b> 134x67mm - transparent	<b>M4124R0</b> 29x87mm - transparent	<b>M6184R0</b> 48x144mm - transparent	<b>M8244R0</b> 134x67mm - transparent			

## Miscellaneous Sign



## Tie Tag



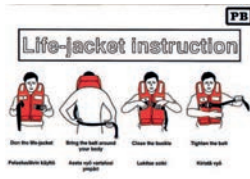

**Donning Instruction**  
210 x 148mm  
self adhesive

**1837100**

for lifejackets

**Anlegeanweisung**  
210 x 148mm  
selbstklebend

für Rettungswesten



**Wall Bracket**  
150 x 150mm - triangle form

**3820000**

for IMO symbols

**Wandhalter**  
150 x 150mm - Dreieckform

für IMO Symbole



Index english  
*Index deutsch*



Index german  
*Index deutsch*

1. Hilfsstander	90	Brückenuhr	211	Ersatzlinse - rot	62, 63, 70	HNA - Stecker	24
2. Hilfsstander	90	CO <sup>2</sup> - Druckgaspatrone	155	Ersatzlinse - rot/grün	62, 63	Haltegurt	136, 139, 152
3. Hilfsstander	90	CO <sup>2</sup> - Feuerlöscher	151	Ersatzlinse - weiß	62, 63, 70	Halter	157, 228
ALS - Notfallsender	146	CO <sup>2</sup> - Patrone	115	Ersatzteilset	184	Halter für Nachtlcht	118
Abdeckplane	192	Chemikalien-Schutzanz.		Fallschirmpatrone	97	Halter für Rettungsstan.	114
Absperrband	217	120-122		Fassung	37, 52, 58, 73	Handbuch	241, 242
Abstandslaterne	73	Chemikalien-Schutzzove.	120	Fassung - P28s	24	Handelsflagge	85-87
Acryglas Kratzer Entfer.	196	Chemikalienschutzhand.	126	Fassung B15d	74	Handlampe	225-227
Adapter	144	Clinometer	216	Fassung B22	73	Handlampen	226
Akku	229	Combination Sign	260, 261	Fassung E27	73	Handlot	235
Alkotester	185, 186	Combination sign	261	Fernglas	206	Handrad	163
Aneroid Barometer	214	Container	99	Festkupplung	158-162	Handschellen	217
Anker - Manöverlaterne	35	DSB - Rettungsinsel - E.	110	Festliegerleuchte	228	Handsprechfunkgerät	216
Anker Manöverlaterne	20	Decksventil	162, 163	Fettbrand - Feuerlösch.	151	Handwindmesser	215
Ankerlaterne	64, 67, 68, 70	Deckwaschschlauch	243	Feuerlöschdecke	175	Hauptschlüsselanlage	217, 218
Anlegeanweisung	270	Desinfektionsmittel	145	Feuerlöschlanze	173	Hazard Symbol Poster	263
Anlegedreieck	212	Desinfektionstücher	192	Feuerlöschschlauch	166, 167	Heck - Schlepplaterne	18, 34, 61, 62
Ansaugschlauch für Sc.	174	Docht	196	Feuerschutzhelm	124, 125	Heck - Suezlaterne	18
Antirutschfolie	178	Doppel - Seitenlaterne	57	Feuerwehr - Sicherheits.	136	Hecklaterne	17, 34, 57, 61, 63
Antisplash Tape	178	Doppel Heck - Suezlate.	18	Feuerwehraxt	175, 176	Heizlüfter	188
Aqua-KEM Blue	189	Doppel Hecklaterne	19	Feuerwehrbeil	176	Hitze - Schutzhandschu.	126, 127
Aqua-Rinse	190	Doppel Heckschlepplat.	19	Filter	172	Hitzeschutzanzug	142
Arbeitshandschuhe	127	Doppel Rommé Karten.	191	Filterpatrone	172	Hitzeschutzanzug Hose	143
Arbeitsoverall	128	Doppel Seitenlaterne	16	Fire / Safety Plan Minis.	267	Hitzeschutzanzug Jack.	143
Arbeitsschutzhelm	124	Doppel Signallaterne	21, 22	Fire / Safety Plan Stick.	267	Hochdruckschlauch	155
Arbeitssicherheitsschuh.	125	Doppel Topplaterne	17	Fischfangergerät	203	Hochtemperaturfettspra.	172
Atemluftkompressor	172	Doppelfarbige Seitenlat.	63	Flaggleinenwirbel	93	Hubschrauber Transfer.	234
Atemmaske	143, 144	Doppelhubpumpe	115	Flasche	195	Hydrometer (Aräometer.	214
Auffanggerät	140	Dose	99, 196	Floor Escape Route	268	Hygieneset	131
Auffanggurt	137, 138	Dreifarbige Seglerlatern.	68	Fluchtfiltergerät	170	Hygrometer	206
Aufkleber - "Seenotsign.	99	Drogenschnelltest	186	Fluchttreter	170	Höhensicherungsgerät	138
Aufsteckhaken	60	Druckgasflasche-Sticks.	155	Flüssigseife	192	ID-Card Behälter	204
Aufsteckhaken - lang	64	Druckkupplung	159	Frottierhandtuch	188	IKAROS - 1-Sternrakete.	94
Aufsteckhaken Set	64	Druckluft-Spray	237	Füllstandsmessgerät -	176	IKAROS - 2-Sternrakete.	94
Augenspüllflasche	187	Drucksprüngerät	181	Galley Sign	246	IKAROS - Fallschirmrak.	94, 95
Augenspüllflüssigkeit	187	Dräger Röhrchen	186	Gally Sign	246	IKAROS - Handfackel	94, 97
Auslösehaken	199, 200	Dräger Sensor	184	Gangwaynetz	234	IKAROS - Kombisignal	97
Auslösehaken unter La.	200	ECO Bordchronometer	212	Gasfilter	135	IKAROS - Leinenschieß.	95
Basis - Messeinheit	32	EEBD Box	171	Gasfilter Bajonett A2	136	IKAROS - Licht - Rauch.	95
Batterie	184, 229, 233	Einbindeapparat	164	Gashorn	83	IKAROS - Rauchfackel	96
Baueimer	237	Einbindedraht	164	Gaskartusche	83, 190	IKAROS - Rauchsignal	96
Baumwollhandschuhe	127	Einbootungsleiter	234	Gasmessgerät	182-184	IMO Symbol	248-251
Befestigungssatz - Reel.	116	Einfilter Halbmaske	133	Gasspürpumpe	182	ISPS - Kasten	224
Begrenzungslaterne	73	Einmal Zahnbürste	188	Gehörschutzmuscheln	129	ISPS Code Sign	262
Benzinkanister	195	Einsteigeleiter	234	Gehörschutzstöpsel	129	ISPS Code Sign	261, 262
Bereitschaftstasche	185	Einweg - Overall	128	Geldkassette	217	ISPS Spiegel	220
Besteckhalter	213	Einwegfeuerzeug	191	Gesichtsschutz	131, 132	Internationaler Landans.	163
Besucher Logbuch	241	Elefantenhaut	237	Gewebeband	179	Kalibriergas	185
Biocid - 100gr.	188	Elektriker - Handschuh.	128	Glasenuhr	211	Kanister	194
Blindkupplung	159-161	Elektrodecke	239	Gleitspray	238	Kappbeil	203
Blitzknallpatrone	97	Epirb	216	Glocke	82	Kappmesser	204
Bootshaken	236	Epoxyharz Kitt	232	Glockenbändsel	82, 83		
Bootspollitur	197	Erkennungsleuchte	75	Glockenhalter	83		
Bootsriemen	202	Ersatz - Linse	66, 67	Glühlampe	23, 71, 117, 228		
Bootswachs	197	Ersatzglas	196	Gummihandschuhe	127		
Brandfluchthaube	170	Ersatzlinse - gelb	70	Gummistiefel	125, 126		
Brandschutzplanbehält.	224	Ersatzlinse - grün	62, 63, 70	HNA - Steckdose	24		



Index german  
*Index deutsch*

Kapselgehörschützer	129, 130	LED - Streifenleuchte	77	Namensschild	219	Rimbox	153
Kapselgehörschützer -	130	LED - Topplaterne	28, 42, 43	National/Handelsflagge	85	Rohraufsatz	67
Kapselgehörschützer m.	130, 131	LED - Warnblitzer	80	Nationalflagge	85	Rohrschellen - Set	118
Karabinerhaken	232, 233	LED Blitzleuchte	48	Nebelgong	82	Rollenkarten	239
Kartenlupe	213	LED Handlampe	227	Nothammer	176	Rollenkartenhalter	239
Kartuschenkocher	190	LED Hindernisfeuer	49	Notlicht	117	Rucksack mit Arzneimit.	187
Kasten	175	LED Signalleuchte	49	Notproviant Ration	202	Rudergabel	202
Kette für Blindkupplung	164	LED Strahler	77	Notsignale Satz	94	Salzwasseraufbereiter -	188
Kielwasserlaterne	73	Ladegerät	227, 228	Notsignalsatz	98	Sammelband Sudoku	191
Kiste	221, 222	Ladeschale mit Stecker.	185	Nähzeug - Set	204	Sammelrettungsgerät	112
Kiste - Sitzbank	222	Laminierfolie	219	Panoramic Fire Sign	250, 251	Sanitätskasten	187, 194
Kiste C - (Toilette/Berg.	192	Landgangstafel	239	Panoramic Fire Sign	250	Sauerstoff - Beatmungs.	187
Kiste für Ölbekämpfung	181	Langplomben	217	Papierkorb	237	Saugkorb	201
Klappmesser	203, 204	Lecksuchgerät	238	Parallel Lineal	213	Saugkupplung	158
Klemmbrett	220	Ledertasche	176	Partikelfilter	134, 135	Schaufel	180
Kombi - Laterne	66	Lenzventil	195	Passengers Sign	262, 263	Schaum - Feuerlöscher	149, 150
Kombinationsfilter	134	Leuchtkonus	228	Peilkompass	199	Schaumkonzentrat	174
Kompass	199	Leuchtstab	205	Pelikanhaken	114	Schaumstrahlrohr	174
Kompass - komplett	198	Leuchtstab - Cyalume	205	Pfosten	223	Schaumzumischer	174
Kompasshaube	199	Lichteinsatz	58, 70, 71	Photoluminescent Tape	268	Scheibe	144
Kopfband	143	Linse	58	Plombe	170	Schiffshalter	152, 153
Krankentrage - 2-teilig	187	Linse - blau	39	Plomben - Satz	238	Schlafbrille	191
Krankentransporttrage	187	Linse - gelb	38	Plombierzange	238	Schlafsack	188
Kriechöl	236	Linse - grün	38	Plombierzange - Thermo- /	208	Schlagpütz	201
Kugelfender	235	Linse - rot	38	Popnieten	58	Schlauch	155, 201
Kugelfender - A3	235	Linse - weiß	38	Pressluftatmer	144	Schlauchhaspel	168
Kunststoffkette	218	Linse - weiß reduziert	38	Pressluftflasche	145	Schlauchkasten	168, 169
Kupplungsdichtring	163, 164	Linse 3-farbig	69	Pressluftflaschenventil	145	Schlauchkupplung	160-162
Kupplungsschlüssel	165	Lotsenjacke	128	Prohibition Sign	259, 260	Schlauchschele	243
Kursdreieck	212, 213	Lotsenleiter	235	Prüfgas Aerosol	175	Schlauchschränk	176
Kurslineal	213	Löschpulver	154	Prüfstabthermometer	207	Schlauchtasche	169
Kälteschutzanzug	203	Löschpulver - PL 17/87	155	Psychrometer - Schleu.	207	Schlüssel	229
LED - Doppel Heck - Sc.	30	MOB - Rutsche	115	Pulver - Feuerlöscher	148, 149	Schlüsselkasten	223
LED - Doppel Heck-Su.	30	Mandatory Sign	255, 256	Pumpe	201	Schränk	222
LED - Doppel Hecklater.	30	Manilaleine	236	Pumpnebelhorn	83, 84	Schraubensicherung	232
LED - Doppel Seitenlat.	28	Marine Barograph	214, 215	Putzlappen	236	Schreibpult für Reeling	217
LED - Doppel Signallat.	31	Marinezirkel	212	Radartransponder	216	Schutzbrille	132
LED - Doppel Topplater.	29	Masthalterung - komple.	46, 47	Rahmen	239	Schutzhaube	154
LED - Doppelseitenlater.	41	Megaphon	84	Rattenblech	240	Schutzhelm für Elektrik.	124
LED - Flutlichtstrahler	79, 80	Mehrzweckstrahlrohr	156	Rattenfalle	238	Schutzkappe	67
LED - Handlampe	225	Messkarte	32	Reflexfolie	178	Schutzscheibe	142
LED - Heck - Schleppla.	41, 42	Metall Detektor	219	Reinigungsset	99	Schweißband	124
LED - Heck-Schlepplat.	29	Mikrofaser Schlafdecke	188	Reinigungstuch	144	Schweißerhandschuh	127
LED - Heck-Suezlatern.	29	Miscellaneous Sign	260, 269	Reparaturset	197	Schwimmer	202
LED - Hecklaterne	29, 41, 42	Mobiles Chemie WC	189	Rettungsdecke	146	Schwimmsonde	184
LED - Kombilaterne	45	Montage - Winkel - Set	116	Rettungsring	111	Schwimmmesser	204
LED - Kombilaterne - m.	45	Montageplatte - Mast	59	Rettungsringhalter	116	Schwingungsdämpfer	25
LED - Kopfleuchte	231	Montageplatte 1	59, 63	Rettungsringkasten	223	Schäkel	232
LED - Salingleuchte	77-79	Montageplatte 2	64	Rettungsschere	238	Schürze	140
LED - Seglerlaterne	45	Montageplatte 3	59	Rettungssstange	113	Seekrankheitstabletten	194
LED - Seitenlaterne	28, 41	Montageplatte 4	59	Rettungsweste - Festst.	102, 103	Seglerlaterne	65
LED - Signallaterne	30, 31, 43, 44	Mundnebelhorn	84	Rettungsweste - aufbla.	103	Seilkantenschutz	192
LED - Strahler	78	Mundstücke	186	103-107		Seitenlaterne	16, 34, 57, 60,
		Nachtlicht	117	Rettungsweste - aufbla.	61	Sicherheits-Abseilset	137
		Nackenschutz	125	Rettungswurfball	113	Sicherheitsleine	136, 137

Index german  
*Index deutsch*

Sicherheitsrolle	239	Textilband	220	zzzz	1
Sicherungsband mit Ba.	139	Thermobecher	191	Öl Netzmittel	181
Sicherungsseil	136, 140	Thermomatte	189	Öl Trocken Granulat	180
Sicherungsseil mit Ban.	139	Thermometer	207-209	Ölbekämpfungssatz	181
Siegel	219	Tie Tag	269	Ölbeutel	200
Signal - Doppelkegel	91, 92	Toilettenpapier	189	Ölentsorgungsfass	181
Signalball	90-92	Topplaterne	17, 34, 57, 61, 62	Ölsaugkissen	180
Signalflagge	88	Touchscreen - 13,3" - T.	32	Ölsaugtuch	180
Signalgeber - Set	96	Tragetasche	230	Ölschleier	180
Signalkegel	90-92	Training - Safety Poster	263-266	Öschläuche	180
Signallaterne	19, 20, 22, 23, 35-37, 65-71	Transparent Evacuation.	268	Öltücher	180
Signalleuchte	50-52	Transportkoffer	221-223	Ösfass	201
Signalpatrone	97, 98	Treibanker	200	Übergangsstück	158
Signalpfeife	114	Treibsatz	95		
Signalpistole	98	Trichter	238		
Signalrhombus	90-93	Trillerpfeife	217, 218		
Signalwimpel	89	Trinkbecher	195		
Signalzylinder	90-92	Trinkwasser Ration	203		
Silikon	237	Trinkwasserkanister	194		
Sitz- und Haltegurt	139	Trommelsextant	215		
Sonnenbrille	132	Turmleuchte	75, 76		
Space Identification Sig.	260, 261	U-Boot - Hecklaterne	75		
Spiele-Set	191	U-Boot - Doppel - Seite.	74		
Sprachrohr - Mundnebe.	84	U-Boot - Hecklaterne	74		
Sprachrohrmundstück	215	U-Boot - Topp - Ankerla.	75		
Sprachrohrtrichter	215	Vaseline	237		
Sprühreiniger	237	Ventil	185		
Spucktüte	204	Verbindungsleine für	98		
Stablampe	226	Visier	125		
Stablampe, 2-zellig	226	Vitonschlauch	184		
Staubmaske	132, 133	Vollsichtschutzbrille	131, 132		
Steatinstift	123	Wandanker	168		
Stechpaddel	202	Wandhalter	153, 270		
Steckdose	25, 59, 60	Wandhalterung	145		
Stecker	24, 59, 60	Warnband	178, 179		
Steckverbindung	59	Warnweste	140, 141		
Steuereinheit	32	Warnweste - orange	218, 219		
Steuerlicht	37, 73	Wasser - Feuerlöscher	151, 152		
Stoppuhr	210	Wasserdruckauslöser	114		
Strahlrohr	156	Wasserstaubrohr	173		
Sturmlaterne	195	Wechselwinkel	60, 64		
Sturmstreichhölzer	205	Wellenberuhigungsöl	200		
Sturzglas	53, 54	Werkzeug - Set	144		
Sturzglas - Linsenform	53	Wurfball	113		
Suchscheinwerfer	229, 230	Wurfballnetz	113		
Sägespäne	180	Wurfleine	191, 197, 198		
Säureschutzhandschuh.	126	Wurfleinenbehälter	197		
Tagessignalscheinwerf.	230	Xenon - Blitzleuchte	48		
Tagessignalspiegel	198	Xenon - Einsatz	48		
Tagsignalscheinwerfer	230	Zweifilter Halbmaske	133-135		
Talkum Puder	145	Zweifilter Silikon Vollma.	135		
Tasche	142	Zweifilter Vollmaske	134		
Teleskopstange	175				
Test - Set	115				
Testlampe für UV-, IR F.	231				

Index english  
*Index englisch*

1. Substitute Pennant	90	Bucket - Edificial	237	Detailed Sighting Comp.	199	Fire Brigade Safety Belt	136
2. Substitute Pennant	90	Budget Glove	127	Disinfectant	145	Fire Escape Hood	170
3. Substitute Pennant	90	Bulb	23, 71, 117, 228	Disposable Overall	128	Fire Hose	166, 167
ALS Survivor Recovery .	146	Bureau Plate for Reelin.	217	Distress - Signals Set	94	Fire Hose Bin	169
Access Ladder	234	CO <sup>2</sup> - Pressure Cartrid.	115	Distress Set	98	Fire Hose Box	168, 169, 176
Acid Glove	126	CO <sup>2</sup> - Fire Extinguisher	151	Distress Signal - Set	96	Fire Hose Reel	168
Acrylic Scratch Remove.	196	CO <sup>2</sup> - Pressure Cartridg.	115, 155	Docked Vessel Light	228	Fire Protection Jacket	143
Adapter	144, 158-162			Donning Instruction	270	Fire Protection Trouser	143
Ärosol Test Gas	175	Cabinet	222	Dosage Valve	185	Firefighter Helmet	124, 125
Air Cylinder	145	Calibrationgas	185	Double Masthead Light	17	Firemans Axe	175, 176
Alcotester	185, 186	Can	99	Double Side Light	16, 57, 63	Firemans Hatchet	176
Allround Lubricant	172	Canister	194	Double Signal Light	21, 22	Fireplan container	224
Alternate Angle	60, 64	Cards	191	Double Stern - Suez Lig.	18	First Aid Kit	187, 194
Anchor Light	64, 67, 68, 70	Carrying Bag	185	Double Stern Light	19	Fishing Tackle	203
Anemometer Digital	215	Carryingbag	230	Double Stern Towing Li.	19	Float Probe	184
Aneroid Barometer	214	Cartouche Digester	190	Double Stroke Air Pum.	115	Floater	202
Anti Slip Foil	178	Cash Box	217	Drain Valve	195	Floor Escape Route	268
Antisplash Tape	178	Chain for Blanc Cap	164	Drinking Cup	195	Foam - Fire Extinguisher.	149, 150
Apron	140	Chart Divider	212	Drinking Water Ration	203	Foam Concentrate	174
Aqua-KEM Blue	189	Chart Magnifier	213	Drug Test	186	Foam Nozzle	174
Aqua-Rinse	190	Charth Ruler	213	Drum Sextant	215	Foggong	82
Backpack with Medica.	187	Chemical Glove	126	Dry Fire Extinguisher P.	154	Foghorn	84
Bag	142	Chemical Protective Ov.	120	Dry fire extinguisher po.	155	Frame	239
Bailer	201	Chemical Protective Ov.	120	Dräger Sensor	184	Freshwater Canister	194
Ball Type Fender	235	Chemical Protective Sui.	120-122	Dräger Tubes	186	Fulminating Cartridge	97
Ball Type Fender - A3	235	Cleaning Set	99	Duct Tape	179	Funnel	238
Barrier Tape	217	Cleaning Spray	237	Dust Mask	132, 133	Galley Sign	246, 269
Basis Measuring Modul.	32	Cleaning Tissue	144	ECO Boardchronomete.	212	Gamble Set	191
Battery	184, 229, 233	Clinometer	216	EEBD Box	171	Gangway Net	234
Battery Charger	227, 228	Combi - Lantern	66	Ear Muff	129, 130	Gas Cartdridge	190
Bell	82	Combination Filter	134	Ear Muff - with helmet a.	130, 131	Gas Detection Pump	182
Bell Clock	211	Combination Sign	260, 261	Ear Plugs	129	Gas Detector	182-184
Bell Holder	83	Combination sign	261	Electrical Blanket	239	Gas Filter	135
Bell Lanyard	82, 83	Compass	199	Electrician Glove	128	Gas Filter Bajonett A2	136
Binding Wire	164	Compass - Complete	198	Electrician Helmet	124	Gas cartridge	83
Binding wire	164	Compressed-Air Spray	237	Elephant Skin	237	Gashorn	83
Binnacle	199	Cone	228	Embarkation Ladder	234	Glassbell	53, 54
Binocular	206	Connecting Rope	98	Emergency Escape Bre.	170	HNA - Plug	24
Blank - Cap	161	Container	99	Emergency Fishing Set	203	HNA - Socket	24
Blank Cap	159, 160	Container Fire Lance	173	Emergency Hammer	176	Handcuffs	217
Boat Hook	236	Control Unit	32	Emergency Light	117	Handheld Marine Radio	216
Boat Polish	197	Cotton Gloves	127	Emergency Ration	202	Handlamp	225-227
Boat Wax	197	Coupling Sealing Ring	163, 164	Epirb	216	Handlamp - Set	226
Bottle	195	Coupling Spanner	165	Epoxy Resin Putty	232	Handlead	235
Box	175, 221, 222	Cover	154	Eye Wash Bottle	187	Handwheel	163
Box - Seat	222	Cover for Extinguisher	154	Eye wash Liquid	187	Hatchet	203
Box C - (Toilett/Rescue.	192	DSB - Liferaft - EP "A"	110	Face Cover Glass	142	Hazard Symbol Poster	263
Box for Oil Spill Equipm.	181	Day Signal-Search Ligh.	230	Face Protection	131, 132	Head Straps	143
Bracket	157, 228	Daylight Signal-Mirror	198	Face cover glass	142	Heat Glove	126, 127
Bracket for Lifebuoy Li.	118	Daylight Signalling Ligh.	230	Fat Burning Fire Exting.	151	Heat Protective Suit	142
Bracket for Rescue Rod	114	Decent System	137	Female Socket	59, 60	Heater	188
Branch Pipe	156	Deckwash Hose	243	Filter	172	Heaving Line	197, 198
Breathing Air Compress.	172	Delimitation Light	73	Filter Cartridge	172	Helicopter Transfer Net	234
Breathing Apparatus	144	Desalinator	188	Filter Escape Device	170	High Pressure Hose	155
Breathing Face Mask	143	Desinfection Tissuis	192	Fire / Safety Plan Stick.	267	Hose	155, 201
Bridge Clock	211			Fire Blanket	175	Hose Binding Device	164
Bucket	201						

Index english  
*Index englisch*

Hose Clip	243	LED Torch	227	Mounting Plate - Mast	59	Prohibition Sign	259, 260,
Hose Coupling	160-162	Laminating Foil	219	Mounting Plate 1	59, 63		269
Hydrostatic Release	114	Landing Valve	162, 163	Mounting Plate 2	64	Prohibition Sign	260
Hygiene Set	131	Lead Seal Tong	238	Mounting Plate 3	59	Protection Cap	67
Hygrometer	206	Leak Detector	238	Mounting Plate 4	59	Protective Goggles	131, 132
ID-Card Container	204	Leather Pocket	176	Mounting Set - Reeling	116	Protector Triangel	213
IKAROS - 1-Star Rocke.	94	Lens	58	Mouthpieces	186	Pump	201
IKAROS - 2-Star Rocke.	94	Lens - blue	39	Multi-Purpose Branch P.	156	Pump Fog Horn	83, 84
IKAROS - Combination .	97	Lens - green	38	Musterlist	239	Radartransponder	216
IKAROS - Hand Smoke.	96	Lens - red	38	Name tag	219	Rat Guard	240
IKAROS - Handflare	94, 97	Lens - white	38	National Flag	85	Rat Trap	238
IKAROS - Light - Smok.	95	Lens - white reduced	38	National/Merchant Flag	85	Rechargeable Battery	229
IKAROS - Linethrowing .	95	Lens - yellow	38	Neck Protection	125	Reducer	158
IKAROS - Parachute R.	94,	Lifebuoy	111	Nitrogen - Pressure Car.	155	Reflective Tape	178
	95	Lifebuoy Box	223	Oar	202	Release Hook	200
IKAROS - Smoke Signa.	96	Lifebuoy Bracket	116	Oil Absorbing Pads	180	Release hook	199
IMO Symbol	248-251, 269	Lifebuoy Light	117	Oil Bag	200	Repair Kit	197
ISPS - Box	224	Lifejacket - Foam	102, 103	Oil Dry Granulat	180	Rescue Apparatus	112
ISPS Code Sign	246, 261,	Lifejacket - inflatable	103-107	Oil Pads	180	Rescue Blanket	146
	262	Light Insert	58, 70, 71	Oil Sorbent Booms	180	Rescue Marine Stretch.	187
ISPS Mirror	220	Lightstick	205	Oil Sorbent Pillow	180	Rescue Rod	113
ISPS Sign	262	Lightstick - Cyalume	205	Oil Sorbent Sweep	180	Rescue Shears	238
Identification Light	75	Line Throwing Containe.	197	Oil Spill Drum	181	Rescue Stretcher - 2 pi.	187
Injection Mixer	174	Line Throwing Rocket	95	Oil Spill Emulsion	181	Rescue Throwing Ball	113
International Shore Con.	163	Liquid Level Indicator - .	176	Oil Spill Set	181	Respirator for Breathing.	144
Jackknife	203, 204	Liquid Soap	192	One Filter Respirator	133	Rimbox	153
Key Box	223	Load Bowl with Plug Po.	185	One Way Lighter	191	Rope Edge Protection	192
Knife Floating	204	Load Line Hydrometer	214	Oxygen Respirator	187	Row Lock	202
LED - Stern Towing Lig.	29,	Lubricant Spray	238	Paddle	202	Safety Device Rope	136, 140
	41, 42	MOB - Quick Release	115	Panoramic Fire Sign	250,	Safety Harness	137-139
LED - Boomlight	78, 79	Mandatory Sign	255, 256,		251	Safety Helmet	124
LED - Combi Light	45		262	Panoranic Fire Sign	250	Safety Line	136, 137
LED - Combi Light - wit.	45	Maneuvering Light	20, 35	Paper Bin	237	Safety Shoes	125
LED - Deck Floodlight	77	Manila Rope	236	Parachute Cartridge	97	Safety Waist Belt	136, 139
LED - Double Masthea.	29	Manoeverung Light	35	Parallel Ruler	213	Sailors Knife	204
LED - Double Side Ligh.	28,	Manual	241, 242	Particle Filter	134, 135	Sawdust	180
	41	Marine Barograph	214, 215	Passengers Sign	262, 263	Screening Grid	144
LED - Double Signal Li.	31	Marine Bracket	152, 153	Pelican Hook	114	Screw Security	232
LED - Double Stern Lig.	30	Marine bracket	152	Penetrating Oil	236	Sea Anchor	200
LED - Double Stern-Su.	30	Mastbracket - complete	46,	Petrol Canister	195	Sea Sickness Bag	204
LED - Floodlight	78-80		47	Photoluminescent Tape	268	Sea Sickness Tablets	194
LED - Masthead Light	28, 42,	Master Key System	217, 218	Pilot Jacket	128	Seal	170, 219
	43	Masthead Light	17, 34, 57,	Pilot Ladder	235	Seal Set	238
			61, 62	Pipe Clamps - Set	118	Seal Strip	217
LED - Side Light	28, 41	Measuring Card	32	Plastic Chain	218	Search Light	230
LED - Signal Light	43, 44	Mebrane reservative - 1.	188	Plug	24, 59, 60	Searchlight	229, 230
LED - Spotlight	78	Megaphon	84	Plug Connection	59	Self Locking Lifeline-Re.	138
LED - Stern - Suez Ligh.	29	Merchant Flag	85-87	Plug socket	25	Sewing Kit	204
LED - Stern Light	29, 41, 42	Metal Detector	219	Polymeter Thermo- / Hy.	208	Shackle	232
LED - Stripe Light	77	Micro Fiber Sleeping Bl.	188	Pop rivet	58	Shelf	213
LED - Tri-Color Light	45	Miscellaneous Sign	260, 269	Post	223	Shock Absorbing Lanya.	139
LED - Warning Flashlig.	80	Mobil Chemical Toilett	189	Powder - Fire Extinguis.	148,	Shock-Absorbing Lanya.	139
LED Flash Light	48	Morse tracer	25		149	Shore Leave Bord	239
LED Handlamp	225	Mounting Bracket - Set	116	Pressure Hose Couplin.	159	Shovel	180
LED Head Lamp	231	Mounting Hook	60	Pressure Sprayer	181	Side Light	16, 34, 57, 60, 61
LED Obstruction Light	49	Mounting Hook - long	64	Procision Sling Psychro.	207	Signal Ball	90-92
LED Signal Light	30, 31, 49	Mounting Hook Set	64			Signal Cartridge	97, 98
LED Spotlight	77						

Index english  
*Index englisch*

Signal Cone	90-92	Survival Suit	108, 109	Water Fog Applicator	173
Signal Cylinder	90-92	Sweatband	124	Wave Calming Oil	200
Signal Double Cone	91, 92	Swirl for Flag Lines	93	Welding Glove	127
Signal Flag	88	Talcum Powder	145	Wellington Boots	125, 126
Signal Light	19, 20, 22, 23, 35-37, 50-52, 65-71	Tarpaulin	192	Whistle	217, 218
Signal Pennant	89	Telescope Rod	175	Wick	196
Signal Pistol	98	Terminal Board	220	Wiping Rags	236
Signal Rhombus	90-93	Test - Kit	115	Working Glove	127
Signaling Whistle	114	Test Slat Thermometer	207	Workingoverall	128
Silicone	237	Testlamp for UV-, IR FI.	231	Xenon Flash Insert	48
Single use Toothbrush	188	Textile Band	220	Xenon Flash Light	48
Sleeping Bag	188	Thermal Mat	189		
Sleeping Goggle	191	Thermal Protective Aid	203		
Slide Chuck	140	Thermocup	191		
Snap Hook	232, 233	Thermometer	207-209		
Socket	37, 52, 58, 73	Throwing Ball	113		
Socket - P28s	24	Throwing Ball Net	113		
Socket B15 d	74	Throwing Line	191		
Socket B22	73	Tie Tag	269		
Socket E27	73	Tin	196		
Space Identification Sig.	260, 261	Toilett Paper	189		
Spacer Light	73	Tool	229		
Spare Lens	66, 67	Tool Set	144		
Spare Lens - green	62, 63, 70	Touchscreen - 13,3" - T.	32		
Spare Lens - red	62, 63, 70	Towel	188		
Spare Lens - red/green	62, 63	Tower Light	75, 76		
Spare Lens - tricolor	69	Training - Safety Poster	263-266		
Spare Lens - white	62, 63, 70	Transparent Evacuation.	268		
Spare Lens - yellow	70	Transport Box	222, 223		
Spare Part Set	184	Transportbox	221		
Spareglass	196	Tri-Color Signal Light	65		
Station Card	239	Tri-Colour Signal Light	68		
Station Card Holder	239	Triangel	212		
Steatin Stick	123	Triangel Nautical Squar.	212		
Steering Light	37, 73	Tube Connector	67		
Stern - Suez Light	18	Two Filter Fullface Res.	134, 135		
Stern - Towing Light	18, 34, 61, 62	Two Filter Respirator	134, 135		
Stern Light	17, 34, 57, 61, 63	Valve for Air Cylinder	145		
Sticker - "Distress Sign.	99	Vaseline	237		
Stopwatch	210	Vibration Absorber	25		
Storm Lantern	195	Visitors Log Book	241		
Storm Matches	205	Visor	125		
Strap	152	Viton Hose	184		
Submarine - Double Sid.	74	Voice - Foghorn	84		
Submarine - Masthead-	75	Voice Hose Funnel	215		
Submarine - Stern Light	74, 75	Voice hose mouth piec.	215		
Suction Hose Coupling	158	Wake Light	73		
Suction Hose for Foam .	174	Wall Bracket	145, 153, 168, 270		
Suction Strainer	201	Warning Tape	178, 179		
Sudoku Set	191	Warning Vest	140, 141, 218, 219		
Sunglasses	132	Water - Fire Extinguish.	151, 152		



